

ST60+ Graphic Display

Owner's Handbook

Document reference: 81268-2
Date: December 2005

Preface

Important information

Safety notices



WARNING: Product installation & operation

This equipment must be installed and operated in accordance with the Raymarine instructions provided. Failure to do so could result in personal injury, damage to your boat and/or poor product performance.



WARNING: Electrical safety

Make sure you have switched off the power supply before you start installing this product.



WARNING: Navigational safety

Although we have designed this product to be accurate and reliable, many factors can affect its performance. Therefore, it should serve only as an aid to navigation and should never replace commonsense and navigational judgement. Always maintain a permanent watch so you can respond to situations as they develop.

EMC conformance

All Raymarine equipment and accessories are designed to the best industry standards for use in the recreational marine environment.

The design and manufacture of Raymarine equipment and accessories conform to the appropriate Electromagnetic Compatibility (EMC) standards, but correct installation is required to ensure that performance is not compromised.

Handbook information

To the best of our knowledge, the information in this handbook was correct when it went to press. However, Raymarine cannot accept liability for any inaccuracies or omissions it may contain.

In addition, our policy of continuous product improvement may change specifications without notice. Therefore, Raymarine cannot accept liability for any differences between the product and the handbook.

Product disposal



Waste Electrical and Electronic (WEEE) Directive

The WEEE Directive requires the recycling of waste electrical and electronic equipment.

Whilst the WEEE Directive does not apply to some of Raymarine's products, we support its policy and ask you to be aware of how to dispose of this product.

The crossed out wheellie bin symbol, illustrated above, and found on our products signifies that this product should not be disposed of in general waste or landfill.

Please contact your local dealer, national distributor or Raymarine Technical Services for information on product disposal.

Contents

Preface	i
Important information	i
Safety notices	i
WARNING: Product installation & operation	i
WARNING: Electrical safety	i
WARNING: Navigational safety	i
EMC conformance	i
Handbook information	i
Product disposal	ii
Contents	iii
Introduction	vii
Data inputs	vii
SeaTalk	vii
Remote control	viii
Mounting options	viii
Parts supplied	ix
Chapter 1: Operation	1
1.1 Getting started	1
Displayed information	1
WARNING: Calibration requirement	1
Switching on and off	1
1.2 Accessing information	1
Selecting pages.....	3
Display types.....	3
Rolling road	4
Graphs	4
1.3 Chapter and page details	5
Depth chapter	5
Speed chapter	6
Wind chapter	6
Heading chapter	7
Navigate chapter	8
Environment chapter	9
Autopilot chapter	9
Favorite chapter.....	9
1.4 Using Favorite pages	9
Setting up Favorite pages	10

- 1.6 Using the track button 11
 - Internal alarms 12
 - External alarms 12
 - Actions to take if an alarm occurs..... 12
 - Silencing internal alarms 12
 - Silencing external alarms 13
 - Illumination..... 13
 - Contrast 14
- Chapter 2: Maintenance & Troubleshooting** 15
 - 2.1 Maintenance 15
 - Servicing and safety 15
 - Instrument 15
 - Cleaning..... 15
 - Cabling..... 15
 - 2.2 Troubleshooting 16
 - Preliminary procedures 16
 - Fixing faults..... 16
 - Technical support 16
 - World wide web 16
 - Telephone help line..... 17
 - Help us to help you 17
- Chapter 3: Installation** 19
 - 3.1 Planning your installation 19
 - Site requirements..... 19
 - CAUTION: Keep the rear of The instrument dry** 20
 - EMC installation guidelines..... 20
 - Suppression ferrites..... 21
 - Connections to other equipment..... 21
 - 3.2 Procedures 21
 - CAUTION: Maintain structural safety** 21
 - Unpacking..... 22
 - Fitting the instrument..... 22
 - Surface mounting 22
 - Flush mounting 23
 - CAUTION: Use the correct screws**..... 24
 - Bracket mounting..... 26
 - Auxiliary alarm option..... 26

3.3 Connecting the display	27
Introduction	27
Mandatory connections	27
Optional connections	27
Connecting to SeaTalk	28
Power requirements	28
CAUTION: Protect the power supply	28
Procedure	29
NMEA IN and OUT connectors	29
Connecting	29
CAUTION: Connections to other equipment	30
Supported NMEA data	30
3.4 Starting procedures	31
Switching on	31
WARNING: Calibration requirement	32
Defining the NMEA OUT connector function	32
EMC conformance	33
Chapter 4: Calibration	35
4.1 Introduction	35
4.2 User calibration	35
Procedure	35
Favorite page rollover	36
Chapter titles	36
Heading type	36
Battery alarm threshold	36
Internal alarms on/off	39
Variation	39
Date format	39
Time format	39
Time offset	39
Units setup	40
NMEA OUT on/off	40
Pilot pop-up	40
Instrument configuration	40
Leaving User calibration	43
4.3 Dealer calibration	43
Summary	43
Procedure	44
User calibration on/off	44
Response settings	45

- Battery voltage..... 45
- WARNING: HIGH VOLTAGE HAZARD**.....45
- Default reset 45
- Self test 47
- Leaving Dealer calibration.....47
- 4.4 Checking operation47
- Basic checks47
- NMEA checks47
- Glossary**49
- Index**.....51

Introduction

Thank you for purchasing a Raymarine product. We are sure your ST60+ instrument will give you many years of trouble-free operation.

This handbook describes how to install and use the Raymarine ST60+ Graphic Display. This instrument provides a wide range of data, on a high quality Dot Matrix Display. The instrument is constructed in a rugged weather-proofed case to provide reliable performance, even under the most demanding conditions.

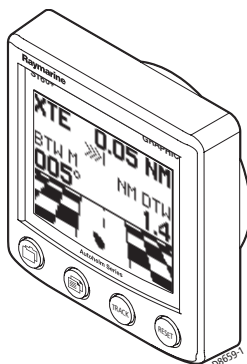

Data inputs

The ST60+ Graphic Display receives data either both from Raymarine via SeaTalk, and from other equipment via NMEA.

SeaTalk

SeaTalk enables a number of compatible instruments to operate as a single, integrated navigational system. Instruments in a SeaTalk system are linked by means of a single cable, which feeds both power and data. Instruments can therefore be added to the system by plugging them into the network. SeaTalk is flexible enough to adapt to any number of compatible instruments without requiring a central processor. SeaTalk can also communicate via an interface, with non-SeaTalk equipment using the internationally-accepted National Marine Electronics Association (NMEA) protocol.

In a SeaTalk system, each instrument can be either a master or dedicated repeater unit. A master instrument is directly connected to a transducer (the device that provides the raw data), and provides data and control appropriate to its function, to all other equipment on the SeaTalk network. A repeater instrument is not

directly connected to a transducer but displays information provided by other equipment in the SeaTalk network.

The ST60+ Graphic Display is a repeater.

Remote control

The ST60+ Graphic Display does not support the SeaTalk Remote remote control function.

Mounting options

A standard ST60+ instrument is surface-mounted at the required location. If you do not want to surface mount your ST60+ Graphic Display, options are available for:

- Flush mounting. If you have ordered the flush mounting option a low-profile bezel and four fixing screws are provided.
- Bracket mounting.

Parts supplied

Unpack your ST60+ Graphic Display and check that the following items are present:

- Item 1, ST60+ Graphic Display fitted with standard bezel for surface mounting.
- Item 2, Fixing studs (2).
- Item 3, Thumb nuts (2).
- Item 4, Gasket.
- Item 5, SeaTalk interconnection cable.
- Item 6, Power cable.
- Item 7, Instrument Cover.
- Item 8, Owner's Handbook. A Warranty document and fitting templates are included in this Handbook.
- Item 9, Quick Start Guide.

If the Auxiliary Alarm option has also been supplied, check that the following items are also included:

- Item 10, Auxiliary Alarm.
- Item 11, Connector block.
- Item 12, Grommet.

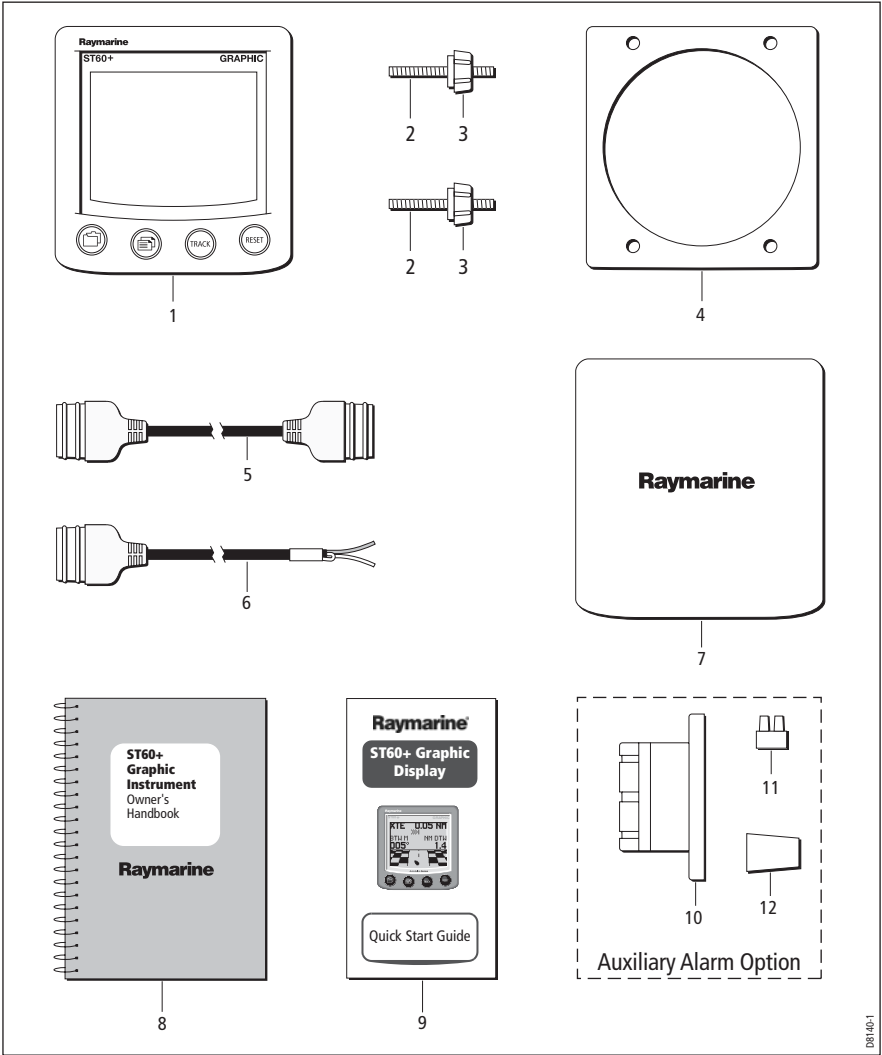

Chapter 1: Operation

1.1 Getting started

Displayed information

Your ST60+ Graphic Display uses a high-quality dot-matrix screen to display a wide range of data, both from Raymarine via SeaTalk, and from other equipment via NMEA. The exact information available for display depends on what data is available and on how the display has been set up.

The ST60+ Graphic Display can also supply SeaTalk data to NMEA 0183.







WARNING: Calibration requirement

To ensure this product performs at its best on your boat, you MUST calibrate it before use, in accordance with the instructions in *Chapter 4, Calibration*. Do NOT use the product until you have successfully calibrated it.

Switching on and off

All the time that power is applied to the instrument, you can use the  button to switch the instrument off and on as follows:

- To switch the instrument off, hold down the  button for approximately 5 seconds. After this time, a switch off count down of 4 seconds occurs. Keep the  button pressed during this period, to switch off the instrument.
- To switch the instrument back on, hold down the  button for approximately 1 second.

When the power supply is switched off, none of the instrument buttons (including ) has any effect.

Notes: (1) *Each time power to the instrument is switched on, the instrument is initially in the on condition. You do not need to use the  button to switch the instrument on.*

(2) *When the instrument is on, the operation of the  button will perform other operating functions, as described below.*

1.2 Accessing information

Information on the ST60+ Graphic Display is organized in groups or 'chapters', and within each chapter, the different types of information are presented as pages. The ST60+ Graphic Display chapters and pages are shown in the following *Chapter selection and content* illustration. This illustration assumes a system where all information sources are available and all pages are enabled.

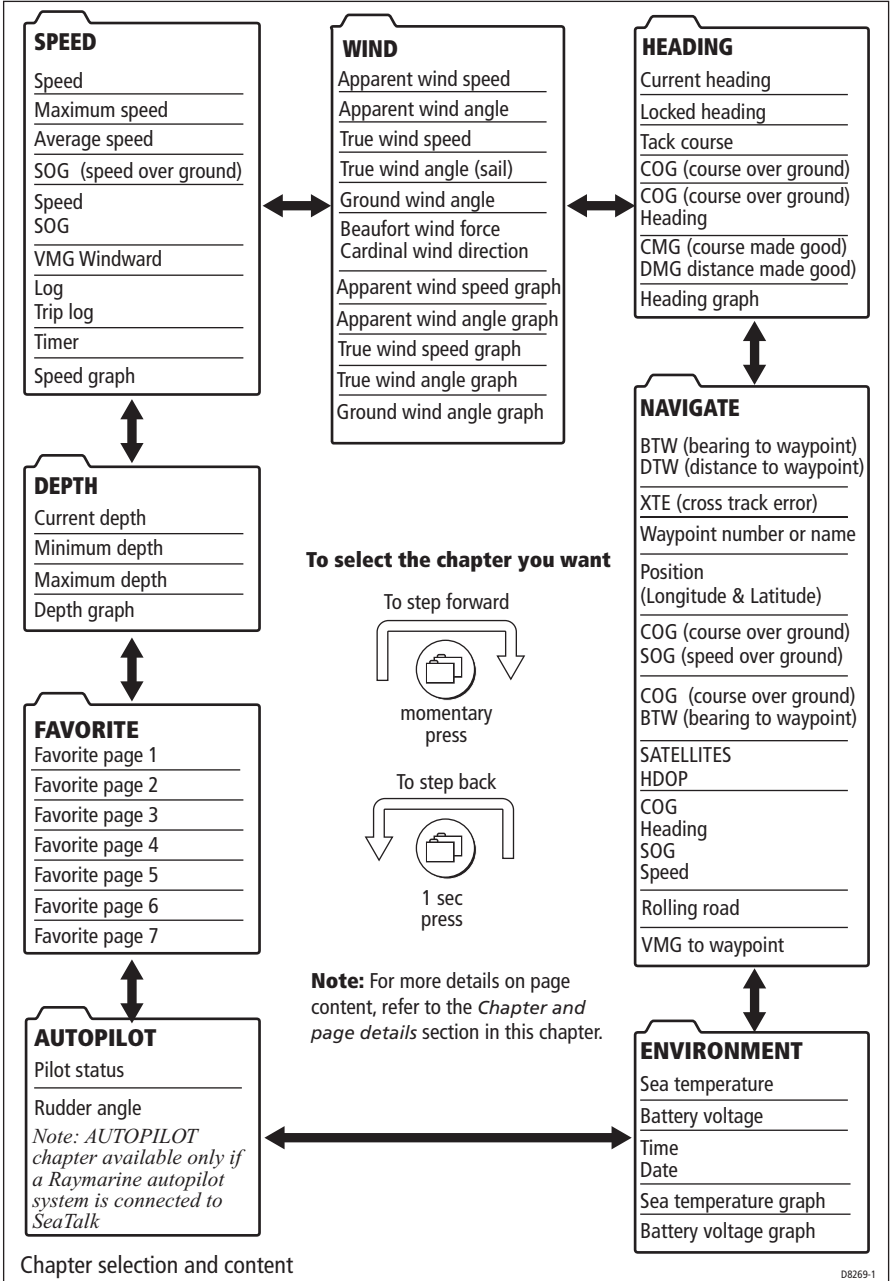

Selecting pages

To see the information you want, refer to the *Chapter selection and content* diagram above, to determine the location of the information you need (i.e. which chapter and page), then:

1. Press the  button the necessary number of times, to select the required chapter. If the chapter title facility is enabled during User calibration, the name of each chapter is briefly displayed when it is first selected.

Note: *Although most chapter names are displayed in full, the Environment chapter is abbreviated to ENVIRONS and the Autopilot chapter is abbreviated to PILOT.*

2. With the appropriate chapter selected, use the  button to select the required page.

The manner in which information is accessed is shown in the following illustration. This shows (as an example) how to display true wind speed information.

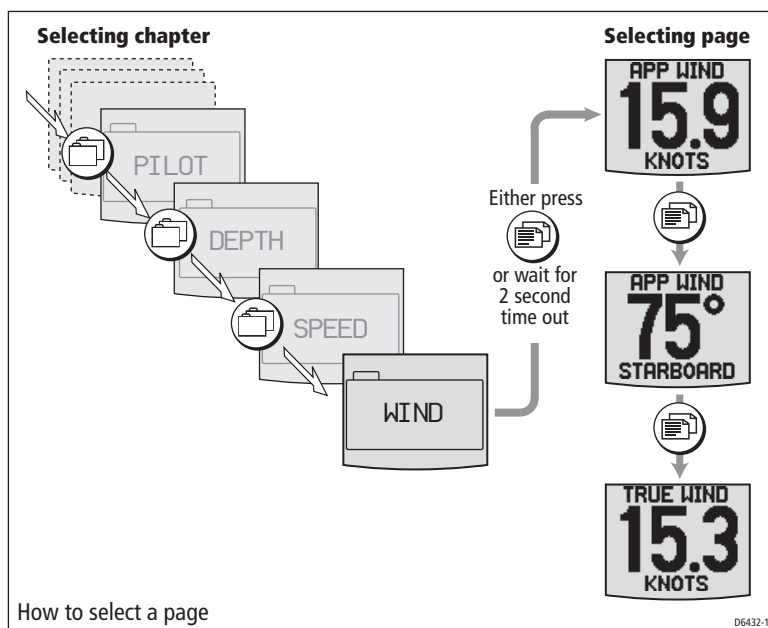

Display types

The ST60+ Graphic Display pages show either 1, 2, 3 or 4 data elements in alphanumeric form. In addition, single-element pages can also show graphic information, such as a rolling road and graphs.

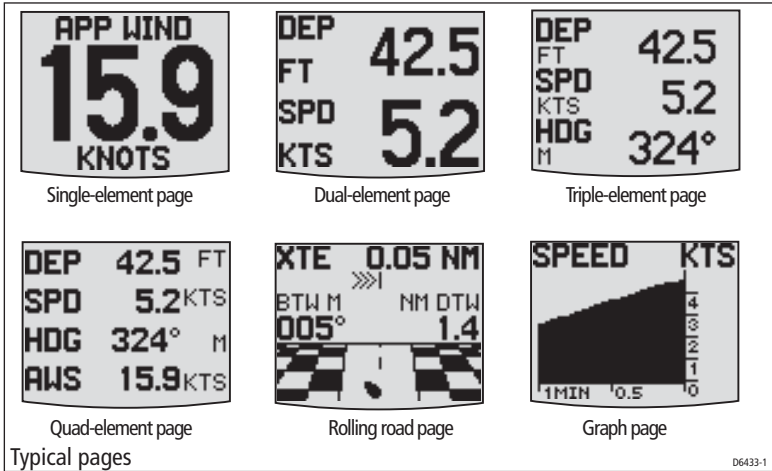

Rolling road

The rolling road is a representation of your vessel's position with respect to a waypoint, and a steer bar shows the direction you should steer to achieve the required course. The number of arrows in the steer bar is proportional to the amount of cross track error; each arrow represents 0.05 nm of error.

The direction of the roll indicates whether you are moving towards or away from the waypoint. A small boat graphic indicates the attitude of your boat with respect to the waypoint.

Cross track error (XTE) information, bearing to waypoint (BTW) information and distance to waypoint (DTW) information are displayed with the rolling road.

Graphs

You can see the history of some information by displaying it as a graph, of data against time. Refer to the *Chapter selection and content* illustration above and the following tables to see where to find the various graphs.

Changing graph timescales

You can change the timescale of a displayed graph. To do this:

1. With the graph displayed, hold down the **reset** button for 1 second, so that the timescale menu is displayed.

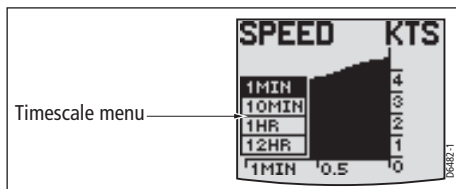

2. Use the **reset** button to select the timescale value you want.
3. Hold down the **reset** button for 1 second, to return to the normal display, with the new timescale selected.

1.3 Chapter and page details

This section lists all the available pages along with titles and salient points.

Note: *The units in which SeaTalk data is displayed, are derived from SeaTalk. The units in which NMEA data is displayed, and the choice of magnetic or true bearing information, are determined during User calibration. See Chapter 4, Calibration.*

Depth chapter

Page	Remarks
DEPTH	Current depth, displayed in either FEET, METERS or FATHOMS. An up arrow is displayed if the sea-bed is rising, and a down arrow is displayed if the sea-bed is falling. If the depth echo is lost, the title is LAST DEPTH and the last valid depth reading is shown flashing.
MIN DEPTH	Minimum depth since power up or last reset, in either FEET, METERS or FATHOMS. Hold down the reset button for 3 seconds, to reset.
MAX DEPTH	Maximum depth since power up or last reset, in either FEET, METERS or FATHOMS. Hold down the reset button for 3 seconds, to reset.
DEPTH (graph)	Depth information in either FEET, METERS or FATHOMS, displayed against time, as a graph.

Speed chapter

Page	Remarks
SPEED	Boat speed, displayed in kilometers per hour (KMH), miles per hour (MPH), or knots (KTS).
MAX SPEED	Maximum speed since power up or last reset, in kilometers per hour (KMH), miles per hour (MPH), or knots (KTS). Hold down the reset button for 3 seconds, to reset to the current speed.
AVG SPEED	Average speed since power up or last reset, in kilometers per hour (KMH), miles per hour (MPH), or knots (KTS).
SOG	Speed over ground, displayed in kilometers per hour (KMH), miles per hour (MPH), or knots (KTS)
SPD SOG	Dual page showing Speed and Speed Over Ground
VMG TO WIND	Velocity made good to windward, displayed in kilometers per hour (KMH), miles per hour (MPH), or knots (KTS).
LOG TRIP	Dual page showing the boat log (total distance covered since the system was installed) and the trip log (distance covered since power up or last reset). Distances are shown in kilometers (KM), or nautical miles (NM).
RACE TIME	Either a count-down timer which shows time remaining to zero (race start) or a count-up timer which shows current count-up time (after race start), in either seconds (S), minutes (M) or hours (H). This information is repeated from SeaTalk. You can control the timer from the master timer instrument on SeaTalk (typically ST60+ Speed or ST290 digital instrument). You cannot control the timer from the ST60+ Graphic Display.
SPEED (graph)	Speed information in kilometers per hour (KMH), meters per second (M/S), or knots (KTS), displayed against time, as a graph.

Wind chapter

Page	Remarks
APP WIND (speed)	Apparent wind speed, in either kilometers per hour (KMH), meters per second (M/S), or knots (KTS).
APP WIND (angle)	Apparent wind angle, in degrees. Shows a STARBOARD indicator when the boat is on a starboard tack and a PORT indicator on a port tack.

Page	Remarks
TRUE WIND (speed)	True wind speed, in either kilometers per hour (KMH), meters per second (M/S), or knots (KTS).
TRUE WIND (angle)	True wind angle, in degrees.
GROUND WIND	Direction of wind over ground, in degrees, either MAG(netic) or TRU(e).
WIND FORCE	Wind speed as a Beaufort scale value and wind direction as a cardinal compass point.
A WIND (graph)	Apparent wind speed in either kilometers per hour (KMH), meters per second (M/S), or knots (KTS), displayed against time, as a graph.
A WIND ANG (graph)	Apparent wind angle information in degrees, displayed against time, as a graph.
T WIND (graph)	True wind speed in either kilometers per hour (KMH), meters per second (M/S), or knots (KTS), displayed against time, as a graph.
T WIND ANG (graph)	True wind angle in degrees, displayed against time, as a graph.
WIND DIR (graph)	Ground wind direction in degrees, displayed against time, as a graph. Shown as either T(rue) or M(agnetic).

Heading chapter

Page	Remarks
HEADING	Current heading, in degrees, either TRUE or MAG(netic).
HEADING	Shows whether the heading is LOCKED or UNLOCKED.
TACK COURSE	Next tack heading, in degrees, either TRUE or MAG(netic).
COG	Course over ground, in degrees, either TRUE or MAG(netic).
COG HDG	Dual page showing course over ground and current heading

Page	Remarks
CMG DMG	Dual page showing course made good, in degrees, true (T) or magnetic (M), and distance made good, in either kilometers (KM), statute miles (SM), or nautical miles (NM).
Note: <i>To reset CMG and DMG, hold down reset for 3 seconds.</i>	
HEADING (graph)	Heading angle in degrees, displayed against time, as a graph. Shown as either T(rue) or M(agnetic).

Navigate chapter

Page	Remarks
BTW DTW	Dual page showing bearing to waypoint, in degrees, ether TRUE or MAG(netic), and distance to waypoint, in kilometers (KM), statue miles (SM), or nautical miles (NM).
XTE	Cross track error in kilometers (KM), statue miles (SM), or nautical miles (NM). A steering bar shows the direction to steer. The number of arrows in the bar is proportional to the amount of cross track error.
WAYPOINT	Waypoint number and name displayed.
POSITION	Current latitude and longitude.
COG SOG	Dual page showing course over ground, in degrees, either TRUE or MAG(netic), and speed over ground, in kilometers per hour (KMH), miles per hour (MPH), or knots (KTS).
COG BTW	Dual page showing course over ground, and bearing to waypoint, in degrees, either TRUE or MAG(netic)
SATELLITES HDOP	Dual page showing GPS information. Number of satellites tracked and horizontal dilution of position.
COG HDG SOG SPD	Quad page showing: <ul style="list-style-type: none"> • Course over ground, in degrees, either TRUE or MAG(netic). • Current heading, in degrees, either TRUE or MAG(netic). • Speed over ground, in kilometers per hour (KMH), miles per hour (MPH), or knots (KTS). • Current speed through the water, in kilometers per hour (KMH), miles per hour (MPH), or knots (KTS).
Rolling road	Rolling road graphic along with XTE, steer bar, BTW and DTW.
VMG TO WP	Velocity made good towards waypoint

Environment chapter

Page	Remarks
SEA TEMP	Sea temperature in either °C or °F.
BATTERY	Battery voltage.
TIME & DATE	Current time, as either 12- or 24-hour clock, set during User calibration (see <i>Chapter 4, Calibration</i>). Current date, in either USA or European format, as set during User calibration (see <i>Chapter 4, Calibration</i>)).
SEA TEMP (graph)	Sea temperature, displayed against time, as a graph. Shown in either °C or °F.
BATT VOLT (graph)	Battery voltage, displayed against time, as a graph.

Autopilot chapter

Page	Remarks
PILOT (status)	Autopilot current status. Either standby (STBY), AUTO mode, VANE mode or track (TRK) mode.
RUDDER	Rudder angle, in degrees either P(ort) or S(tarboard).

Favorite chapter

See *Using Favorite pages* below.

1.4 Using Favorite pages

A FAVORITE chapter enables you to group together, information you use most often. You can include information from any other chapter as a page in the Favorite chapter, up to a maximum of seven Favorite pages.

To see the Favorite pages, use the  button to select the FAVORITE chapter and the  button to select the required Favorite pages.

You can set up each Favorite page in any one of the following formats:

- Single element. You can set a single element Favorite page to show any page from any other chapter, including rolling road, graphs and existing double, triple and quad-element pages.
- Multi-element pages. On multi-element Favorite pages you can set the data in each element individually, to create your own dual, triple and quad-element

Favorite pages. You cannot include the rolling road or graphs on multi-element pages.

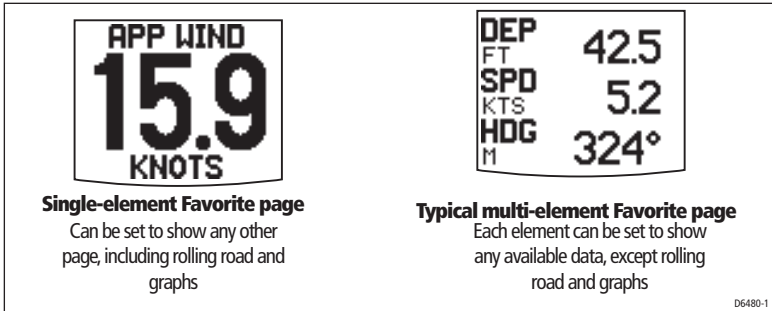

Setting up Favorite pages

As there are seven Favorite pages, you may like to use these to display data from each of the other chapters. So for example, on Favorite page 1, you could show selected data from the Depth chapter, Favorite page 2 could show selected Speed data, and so on.

To setup the data you want on each Favorite page:

1. With the **FAVORITE** chapter displayed, select the page you want to set up.
2. Hold down the **track** and **reset** buttons for approximately 2 seconds, to enter the Favorite page setup mode.
3. Use the **reset** button to show the format you want, i.e. single element, dual element, triple element or quad element. One element is highlighted (white text on a black background), to show that is selected for adjustment.
4. If you have chosen a multi-element page, use the **track** button to move the highlight to the page element you want to set up.
5. Use the  button to cycle to the data you want.
6. If you want to set up another element on this page, repeat steps 4 and 5.
7. Hold down the **track** and **reset** buttons for approximately 2 seconds, to leave the Favorite page setup mode.
8. Repeat the above procedure for all Favorite pages you want to set up.

Refer to the *User calibration* procedure in *Chapter 4, Calibration*, for details of how to set up:

- How many Favorite pages are made available.
- Whether Favorite pages roll around automatically in sequence, or you manually select individual pages.

1.5 Autopilot information

If a Raymarine Autopilot is connected to SeaTalk, you can use the Autopilot chapter to show the current pilot status. During User calibration (see *Chapter 4, Calibration*), you can also set the ST60+ Graphic Display to show the autopilot status on pop-up pages, whenever the autopilot status changes. Examples of instances when a pilot pop-up can occur are:

- Engage autopilot
- Disengage autopilot
- Change of course
- Enter track mode
- Enter vane mode

Autopilot pop-up pages have a border to distinguish them from the other pages, and are displayed for 5 seconds.

1.6 Using the track button

If your system includes a SeaTalk autopilot working in conjunction with a track plotter, you can operate the track plotter in track mode, as follows:

1. Press the **track** button once, so the track plotter enters track mode.
2. In track mode, to plot a track to the next waypoint, hold down the **track** button for 1 second.
3. To leave track mode, press the **track** button again.

1.7 Alarm messages

The ST60+ Graphic Display supports a range of SeaTalk alarm signals and responds with an internal buzzer and an appropriate on-screen alarm message.

In addition to this, the ST60+ Graphic Display can also provide external alarm signals for the Auxiliary Alarm option.

The range of available alarms depends on:

- What data is available on SeaTalk.
- Which alarms are enabled during User calibration (see *Chapter 4, Calibration*).

Internal alarms

The internal alarms are as follows:

Message	Meaning
ANCHOR ALARM (with current depth)	Deep or shallow anchor alarm
SHALLOW ALARM (with current depth)	Shallow water alarm
DEEP ALARM (with current depth)	Deep water alarm
HIGH WIND ALARM (with current wind speed)	High wind speed alarm
RADAR ALARM	Radar guard zone alarm
LOST FIX ALARM	Lost fix alarm
LOW BATTERY ALARM (with current voltage)	The battery voltage has fallen below the specified low-voltage level.

External alarms

An optional Auxiliary Alarm can be fitted at a convenient remote position, to give a loud, audible indication if any one of a range of alarms occurs. This option is particularly useful for situations where high ambient noise may make it difficult to hear the instrument's internal alarm (e.g. aboard a power boat).

Note: *An Auxiliary Alarm cannot be used if the **NMEA OUT** port is being used for NMEA data.*

Actions to take if an alarm occurs

If an alarm occurs, investigate the cause immediately and if possible, take appropriate action to remove the cause. If an alarm message is displayed, use this to guide your course of action.

Silencing internal alarms

You can silence an internal alarm by pressing any one of the ST60+ Graphic Display front panel buttons. Remember though, that removing the alarm sound does not remove the cause of an alarm. If the alarm condition persists, the alarm will recur.



Silencing external alarms

Most external alarms can be silenced only at the alarm-initiating device e.g. autopilot, GPS or master instrument. Exceptions to this are the LOST FIX ALARM and the LOW BATTERY ALARM, which can be silenced by pressing any of the ST60+ Graphic Display front panel buttons.

1.8 Display settings

Illumination

When the instrument is first powered up, the display backlighting is set to its lowest (courtesy) level, to facilitate initial access to the buttons. To adjust the level of backlighting:

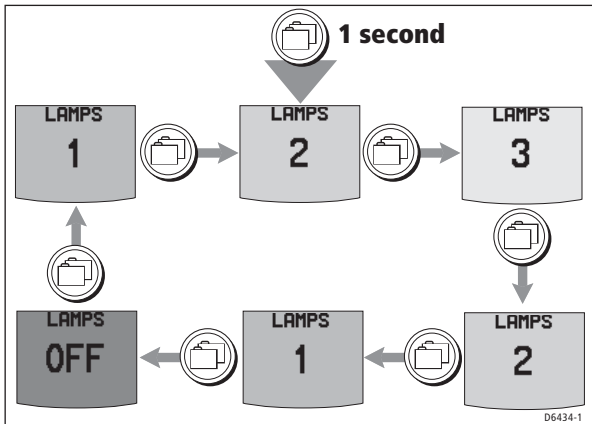

1. Hold down the  button for approximately 1 second, to enter the backlighting-adjust mode.
2. There are four preset backlighting levels. Momentarily press the  button to cycle through these levels until you reach the level you want.
3. Press any other button to leave the backlighting-adjust mode.

Note: *The display will time out to normal operation 5 seconds after the last button press.*



Contrast

To adjust the display contrast:

1. Hold down the  button for approximately 1 second, to enter backlighting-adjust mode.
2. While in backlighting-adjust mode, hold down the  button for approximately 1 second, to enter the contrast-adjust mode.
3. Use the **track** or **reset** button to set the contrast to the required level.
4. Press the **page** button to leave the contrast-adjust mode.

Note: *The display will time out to normal operation 5 seconds after the last button press.*

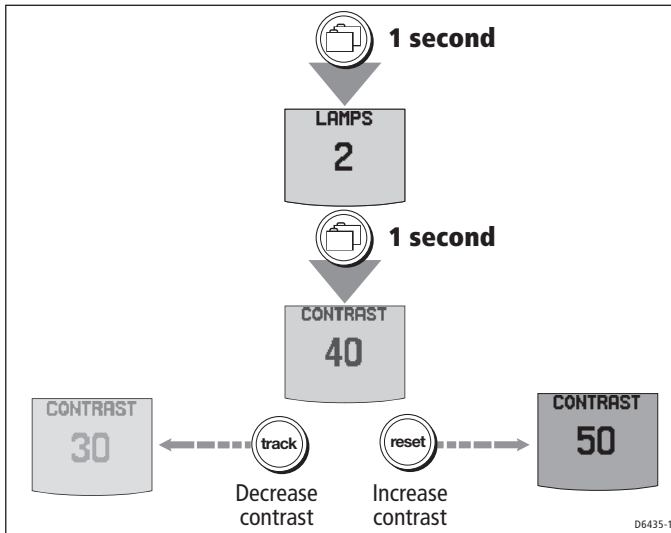

Chapter 2: Maintenance & Troubleshooting

2.1 Maintenance

Servicing and safety

- Raymarine equipment should be serviced only by authorised Raymarine service technicians. They will ensure that servicing procedures and replacement parts used will not affect performance. There are no user-serviceable parts in any Raymarine product.
- Some products generate high voltages, and so never handle the cables/connectors when power is being applied to the equipment.
- When powered up, all electrical equipment produces electromagnetic fields. These can cause adjacent pieces of electrical equipment to interact with one another, with a consequent adverse effect on operation. In order to minimise these effects and enable you to get the best possible performance from your Raymarine equipment, guidelines are given in the installation instructions, to enable you to ensure minimum interaction between different items of equipment, i.e. ensure optimum Electromagnetic Compatibility (EMC).
- Always report any EMC-related problem to your nearest Raymarine dealer. We use such information to improve our quality standards.
- In some installations, it may not be possible to prevent the equipment from being affected by external influences. In general this will not damage the equipment but it can lead to spurious resetting action, or momentarily may result in faulty operation.

Instrument

Certain atmospheric conditions may cause condensation to form on the instrument window. This will not harm the instrument and can be cleared by increasing the illumination setting to Level 3.

Cleaning

Do not use chemical or abrasive materials to clean your instrument. Do not wipe the instrument with a dry cloth as this could cause scratches.

Periodically clean your ST60+ Graphic Display with a soft damp cloth.

Cabling

Periodically examine all cables for chafing or other damage to the outer shield, and where necessary, replace and re-secure.

2.2 Troubleshooting

Preliminary procedures

Changes in the electronic environment may adversely affect the operation of your ST60 equipment. Typical examples of such changes are:

- Electrical equipment has recently been installed or moved aboard your vessel.
- You are in the vicinity of another vessel or shore station emitting radio signals.

If you appear to have a problem, first ensure that the EMC requirements are still being met before further investigating the problem.

Fixing faults

Some data types may not be supported by your system and therefore will not be displayed on your ST60+ Graphic Display. If you think that data is missing, ensure that your system supports this data before assuming that a fault exists.

All Raymarine products are subjected to comprehensive test and quality assurance programmes prior to packing and shipping. However, if a fault occurs, the following table may help to identify and rectify the problem.

Fault	Cause	Remedy
Display blank.	No power supply.	Check power supply. Check SeaTalk cabling and connector security. Check fuse/circuit breaker.
No transfer of information between SeaTalk instruments (e.g. illumination levels).	SeaTalk cable or connector fault.	Check security of SeaTalk connectors. Check condition of SeaTalk cables. Isolate faulty instrument by disconnecting instruments one by one.
Failure of a group of SeaTalk instruments.	SeaTalk cable or connector fault.	Check the security of SeaTalk connectors between functioning and non-functioning instruments.

Technical support

Raymarine provides a comprehensive customer support service, on the world wide web and by telephone help line. Please use either of these facilities if you are unable to rectify a problem.

World wide web

Please visit the Customer Support area of our web site at:
www.raymarine.com

As well as providing a comprehensive Frequently Asked Questions section and servicing information, the web site gives e-mail access to the Raymarine Technical Support Department and a details of the locations of Raymarine agents, worldwide.

Telephone help line

If you do not have access to the world wide web, please call our help line.

In the USA, call:

- +1 800 539 5539, extension 2444 or
- +1 603 881 5200 extension 2444

In the UK, Europe the Middle East or the Far East, call:

- +44 (0) 23 9271 4713 (voice)
- +44 (0) 23 9266 1228 (fax)



Help us to help you

When requesting service, please quote the following product information:



- Equipment type.
- Model number.
- Serial number.
- Software issue number.

The Software issue number can be ascertained by means of the Intermediate Calibration facility, see *Chapter 4, Calibration*.

To find out the software version number and serial number of your ST60+ Graphic Display:

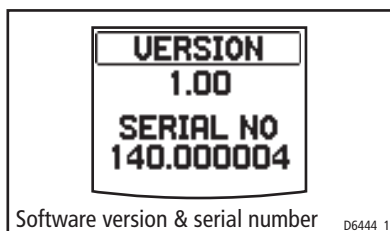
1. During normal operation, hold down the  and  buttons for approximately 4 seconds, to display the **VERSION** screen.



2. Note the software version number and serial number, then hold down the  and  buttons for approximately 2 seconds, to return to normal operation.

Chapter 3: Installation

This chapter describes how to install the ST60+ Graphic Display.

For advice, or further information regarding the installation of this equipment, please contact the Raymarine Product Support Department or your own National Distributor.

3.1 Planning your installation

Before starting the installation, spend some time considering the best position for the instrument, such that the *Site requirements* and the *EMC installation guidelines* (below) are satisfied.

Site requirements

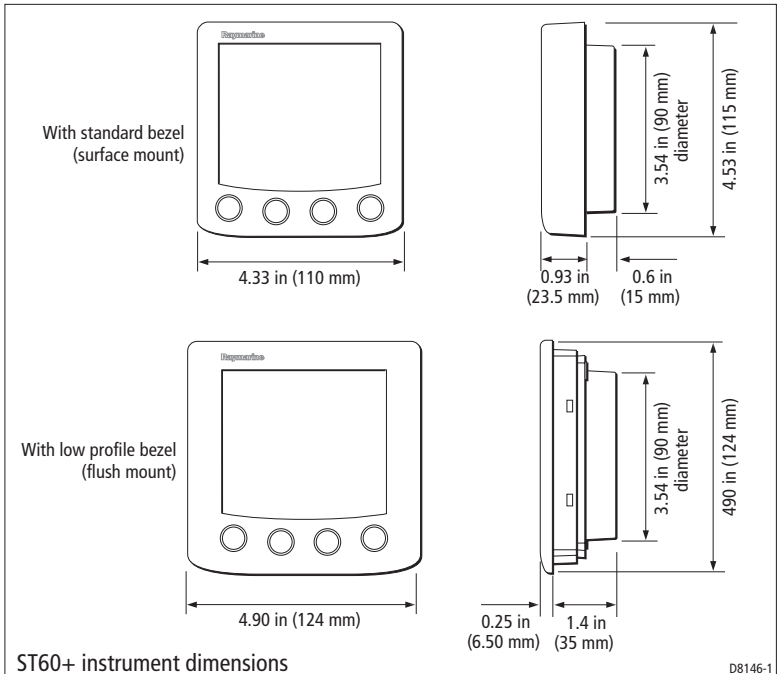

CAUTION: Keep the rear of The instrument dry

Keep the rear of the instrument dry. Failure to observe this caution could result in damage if water enters the instrument through the breathing hole or comes into contact with the electrical connectors.

ST60+ instruments can be fitted either above or below deck, provided the rear of the instrument is sited where it is protected from contact with water.

Each instrument must also be positioned where:

- It is easily read by the helmsman.
- It is protected against physical damage.
- It is at least 9 in (230 mm) from a compass.
- It is at least 20 in (500 mm) from radio receiving equipment.
- There is reasonable rear access for installation and servicing.

EMC installation guidelines

All Raymarine equipment and accessories are designed to the best industry standards for use in the recreational marine environment.

Their design and manufacture conforms to the appropriate Electromagnetic Compatibility (EMC) standards, but correct installation is required to ensure that performance is not compromised. Although every effort has been taken to ensure that they will perform under all conditions, it is important to understand what factors could affect the operation of the product.

The guidelines given here describe the conditions for optimum EMC performance, but it is recognized that it may not be possible to meet all of these conditions in all situations. To ensure the best possible conditions for EMC performance within the constraints imposed by any location, always ensure the maximum separation possible between different items of electrical equipment.

For **optimum** EMC performance, it is recommended that **wherever possible**:

- Raymarine equipment and cables connected to it are:
 - At least 3 ft (1 m) from any equipment transmitting or cables carrying radio signals e.g. VHF radios, cables and antennas. In the case of SSB radios, the distance should be increased to 7 ft (2 m).
 - More than 7 ft (2 m) from the path of a radar beam. A radar beam can normally be assumed to spread 20 degrees above and below the radiating element.
- The equipment is supplied from a separate battery from that used for engine start. Voltage drops below 10 V in the power supply to our products, and

starter motor transients, can cause the equipment to reset. This will not damage the equipment, but may cause the loss of some information and may change the operating mode.

- Raymarine specified cables are used. Cutting and rejoining these cables can compromise EMC performance and must be avoided unless doing so is detailed in the installation manual.
- If a suppression ferrite is attached to a cable, this ferrite should not be removed. If the ferrite needs to be removed during installation it must be reassembled in the same position.

Suppression ferrites

The following illustration shows typical cable suppression ferrites used with Raymarine equipment. Always use the ferrites supplied by Raymarine.

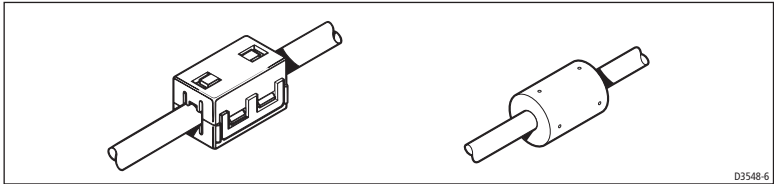

Connections to other equipment

If your Raymarine equipment is to be connected to other equipment using a cable not supplied by Raymarine, a suppression ferrite **MUST** always be attached to the cable near the Raymarine unit.

3.2 Procedures

As it is not possible to describe procedures for all possible installation scenarios, the procedures given here describe the broad requirements for installing the ST60+ Graphic Display. Adapt these procedures as appropriate, to suit your individual requirement.

CAUTION: Maintain structural safety

Where it is necessary to cut holes (e.g. for cable routing and instrument mounting), ensure that these will not cause a hazard by weakening critical parts of the vessel's structure.

Unpacking

Unpack your ST60+ equipment and check that the items described in the *Preface* are present.

Each ST60+ instrument is supplied with a standard bezel for surface mounting. Optional mounting kits are available for flush mounting and bracket mounting the instrument. If you have ordered the flush mounting option a low-profile bezel and four fixing screws are also provided.

Fitting the instrument

The ST60+ Graphic Display can be installed using one of a number of different mounting options:

- Surface mounting. Gives a profile of approximately 0.95 in (24 mm).
- Flush mounting. Gives a profile of approximately 0.25 in (6 mm).
- Bracket mounting.

The ST60+ Graphic Display can also be mounted behind a panel with just the instrument dial and buttons visible.

Surface mounting

To surface mount your ST60+ Graphic Display (see the *Surface mounting* illustration):

1. Ensure that:
 - The selected location is clean, smooth and flat.
 - There is sufficient space behind the selected location to accommodate the rear of the instrument and connectors.
2. Apply the surface mount template (supplied at the rear of this handbook) to the selected location and mark the centers for the fixing studs (1) and the aperture (3) that will take the rear casing of the instrument.
3. Drill out the two 0.2 in (5 mm) fixing stud clearance holes (2).
4. Cut out the clearance hole (3) then remove the template.
5. Peel off the protective sheet from the self-adhesive gasket (4) then stick the gasket into position on the rear of the instrument.
6. Screw the two fixing studs into the threaded sockets on the rear of the instrument.
7. Mount the assembled instrument, studs, bezel and gasket into the panel. Secure from behind with the thumb nuts (5).

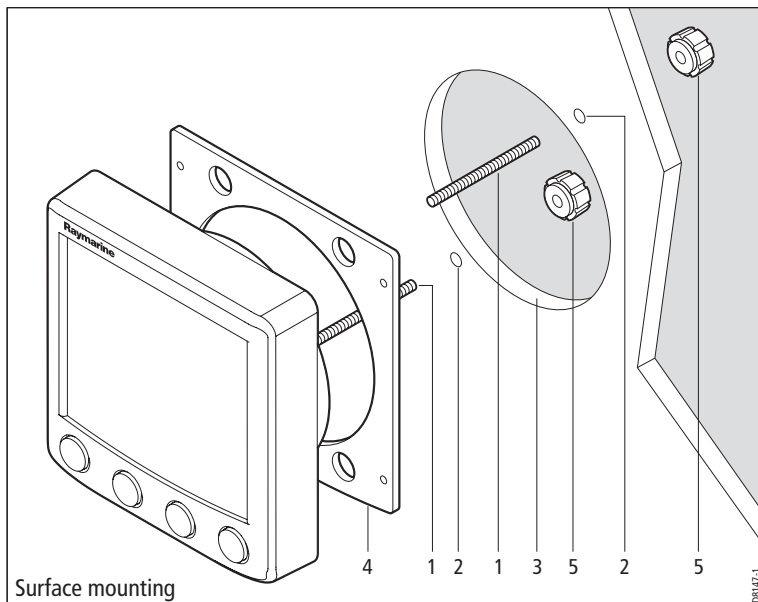

Flush mounting

The Flush Mounting Kit uses a low-profile bezel to reduce the fitted profile of the instrument, to approximately 0.25 in (6 mm) above the panel fascia.

Fitting the flush mount bezel

In order to flush-mount your ST60+ instrument, you must first replace the standard bezel with the flush mount bezel as follows:

1. Hold the instrument in both hands with the display towards you.

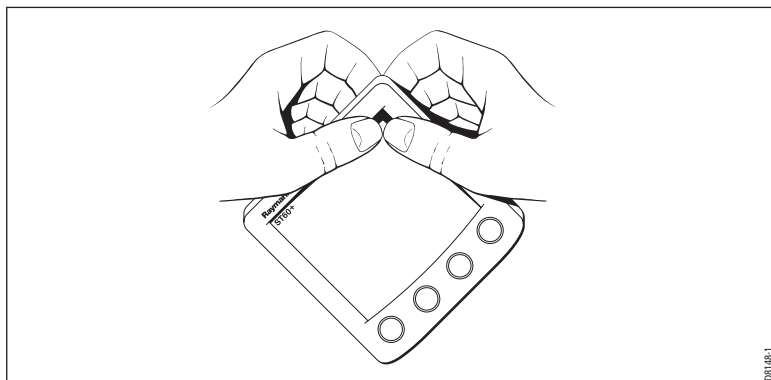

2. Using both thumbs, gently press an upper corner of the instrument from the bezel, then remove the bezel from the instrument. Retain the rubber keypad which is released when the bezel is removed.
3. Referring to the *Fitting the flush mount bezel* illustration, insert the panel seal (8) in the corresponding recess on the back of the flush mount bezel (7).

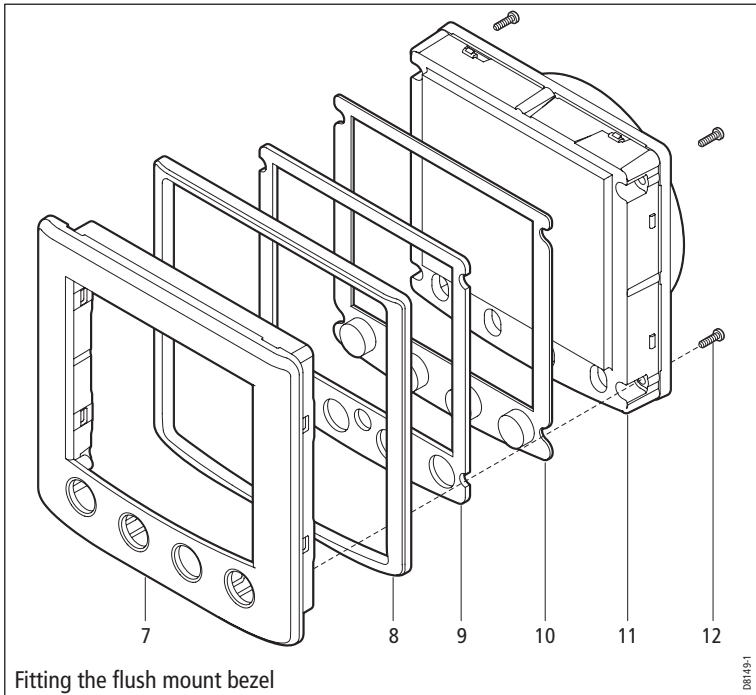

4. Place the instrument (11) face upwards on a flat surface, then place the rubber keypad (10) in position around the display window (i.e. so that each button outline is located over its associated button on the instrument).
5. Place the keypad seal (9) in position on the keypad (i.e. so that the holes in the seal accept the appropriate keypad buttons).
6. Place the assembled flush mount bezel and panel seal, in position on the instrument, so that the rubber keys are correctly located in the holes on the bezel, then clip the bezel and instrument together.

CAUTION: Use the correct screws

It is essential that only screws of the correct size are used to secure the instrument to the bezel. Failure to observe this caution could result in damage to both the instrument and the bezel.

- Using the four, self-tapping screws (12) provided, secure the instrument and bezel together. Fit the screws from the rear of the instrument and tighten them sufficiently to secure the instrument and bezel together. **DO NOT OVERTIGHTEN.**

Flush mounting procedure

Flush mount your ST60+ Graphic Display (see the *Flush mounting* illustration) as follows:

- Assemble the ST60+ Graphic Display and low-profile bezel as described under *Fitting the low-profile bezel*.
- Ensure that:
 - The panel on which you intend to mount the instrument is between 0.12 in (3 mm) and 0.78 in (20 mm) thickness.
 - The selected location is clean, smooth and flat.
 - There is sufficient space behind the selected location to accommodate the rear of the instrument and connectors.
- Apply the flush mount template (supplied at the rear of this handbook) to the selected location and mark out the aperture into which the assembled instrument and bezel will sit.

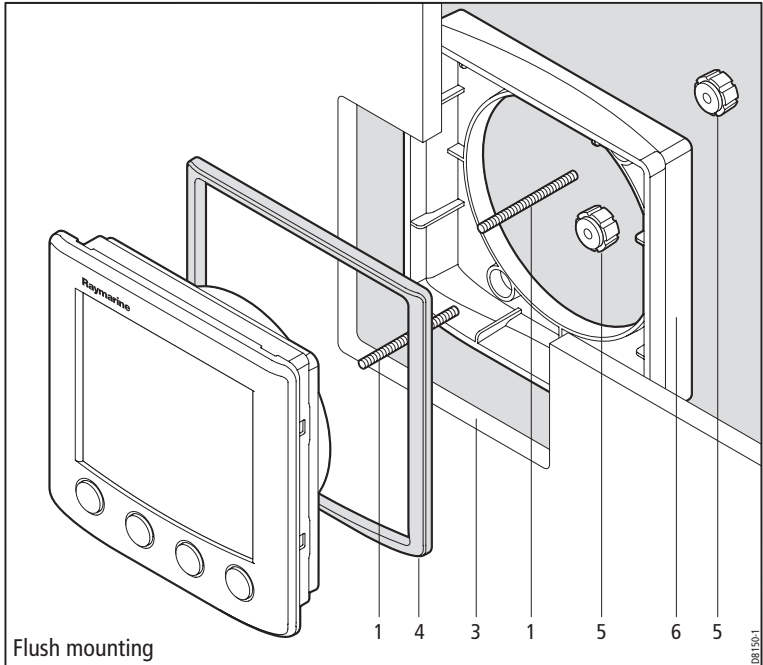

4. Cut out the aperture (3) for the assembled instrument and bezel and remove the template.
5. Peel off the protective sheet from the self-adhesive gasket (4) then stick the gasket into position on the rear of the bezel.
6. Screw the two fixing studs (1) into the threaded sockets on the rear of the instrument.
7. Mount the assembled instrument, studs, bezel and gasket into the panel.
8. Locate the flush mount bracket (6) onto the fixing studs and secure the assembly to the panel with the thumb-nuts (5).

Bracket mounting

A Control Unit Mounting Bracket (Part No. E25009) enables you to mount your the ST60+ Graphic Display in locations where other forms of mounting are impractical. Although this provides a useful alternative method for securing your instrument, it is only suitable for use in positions where the instrument will not be exposed to water.

To bracket mount your ST60+ instrument, do so in accordance with the Control Unit Mounting Bracket Instruction Sheet.

Auxiliary alarm option

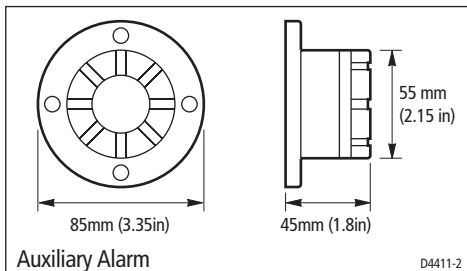

The Auxiliary Alarm is waterproof and can be mounted on a panel either above or below deck, as follows:

1. Drill a $\frac{7}{8}$ in (22 mm) diameter hole through the mounting panel as shown.
2. Insert the grommet supplied into the hole.
3. Feed the connecting wires through the drilled hole, then connect them to the connector block.
4. Place the Auxiliary Alarm in position, and secure it using the four self-tapping screws (supplied).

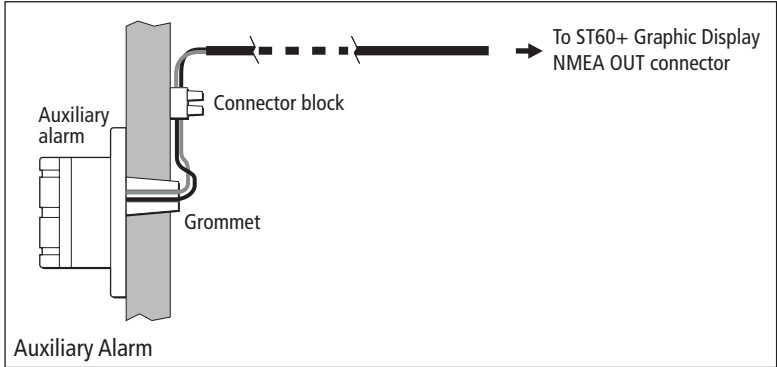

5. Connect a 2-core cable to the connector block and run the other end of the cable to the rear of the ST60+ Graphic Display. The manner in which you run the cable will depend on the locations of the Auxiliary Alarm and display, but in any case, observe the following guidelines:
 - If the cable has to be fed through the deck, always use a proprietary deck gland.
 - Where cables are fed through holes, always use grommets to prevent chafing.
 - Secure long cable runs so they do not present a hazard.

3.3 Connecting the display

Introduction

Mandatory connections

The ST60+ Graphic Display receives both data and power from SeaTalk. You must therefore connect at least one SeaTalk cable from the ST60+ Graphic Display to SeaTalk as described below.

As it is not practical to describe connections for all possible SeaTalk configurations, the instructions given here describe the general requirement. Adapt these instructions, to suit your particular situation. A range of Raymarine SeaTalk extension cables and Raymarine 3-way SeaTalk junction boxes are available to provide maximum flexibility when installing your display.

Optional connections

The **NMEA IN** and **NMEA OUT** connectors provide a useful means of communicating with external systems, but you can carry out all basic operations without making any NMEA connections.

Connecting to SeaTalk

Power requirements

CAUTION: Protect the power supply

Ensure that the 12 V power supply for the SeaTalk bus is protected by a 5 A fuse or circuit breaker.

Systems with a large number of instruments on the SeaTalk bus may require connections to the power supply from each end of the system ('ring-main' style), to maintain sufficient voltage throughout the system.

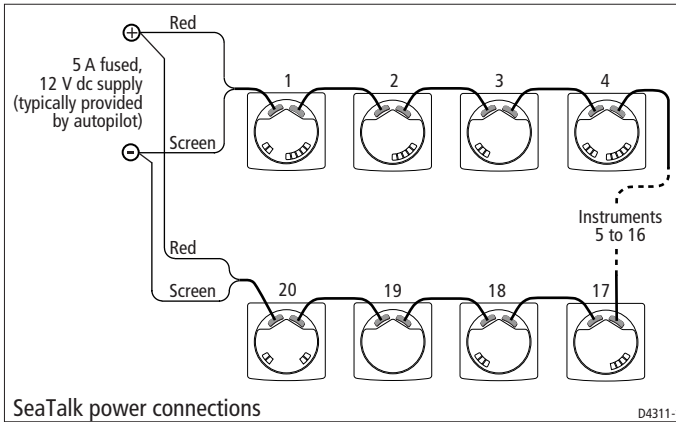

This requirement depends on the total length of the SeaTalk cable run and the total number of instruments in the system. Before connecting the ST60+ Graphic Display, ensure that the system with the display included, will receive a satisfactory power supply. The requirements for power connections are detailed in the following table.

SeaTalk cable run	No. of instruments	Power connections
Up to 10 m	13 maximum	To one end of the system
	26 maximum	To both ends of the system
Up to 20 m	7 maximum	To one end of the system
	13 maximum	To both ends of the system

Procedure

Connect your ST60+ Graphic Display as follows:

1. Ensure that:
 - Power to the existing SeaTalk system is switched off.
 - The conditions described under *Power requirements* are fulfilled.
2. Plug the SeaTalk cable(s) from the rear of the display into a vacant SeaTalk connector on an adjacent instrument. You can either break an existing SeaTalk chain, or connect to the end of the SeaTalk bus.

NMEA IN and OUT connectors

The **NMEA IN** and **NMEA OUT** connectors can be used to receive NMEA data from and transmit NMEA data to external equipment, respectively. When the Auxiliary Alarm option is fitted (see above), the **NMEA OUT** connector is used to connect alarm signals to an Auxiliary Alarm instead of providing an NMEA connection.

Note: *If you connect the **NMEA OUT** connector to an Auxiliary Alarm, you can still use the **NMEA IN** connector to receive data from NMEA.*

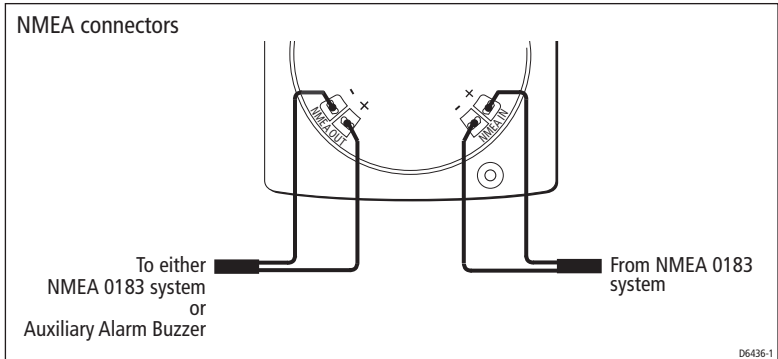

Connecting

Although the NMEA connectors provide a useful means of interfacing with external systems, you do not HAVE to connect to NMEA if you will receive all the data you want from SeaTalk.

To ensure EMC compliance when connecting the **NMEA OUT** connector to an external NMEA product, always use a shielded cable to make the connection and connect the shield to an RF ground point at each end of the cable .

CAUTION: Connections to other equipment

If you are connecting any Raymarine product to other equipment, using a non-Raymarine cable, you MUST fit an appropriate suppression ferrite to the cable near to the Raymarine product.

To connect to your **NMEA IN** and **NMEA OUT** connectors:

- Prepare the cable for connection to the ST60+ Graphic Display, as in the following illustration, then crimp a spade connector to each wire.
- For cables connecting to external products from other manufacturers, ensure a ferrite is fitted to each cable, adjacent to the ST60+ Graphic Display.
- Push the spade connectors onto the appropriate connector pins of the NMEA connectors.
- If you are connecting the **NMEA OUT** connector to an external NMEA product, connect each end of the cable shield to RF ground.

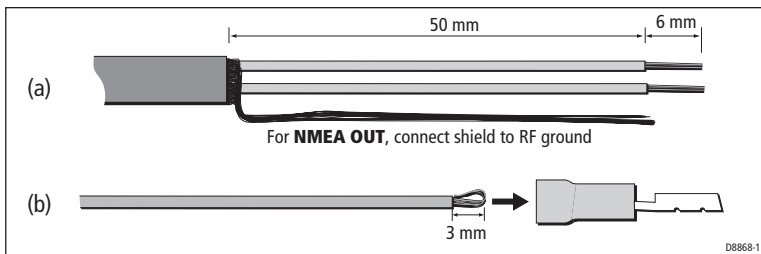
**Supported NMEA data****SeaTalk to NMEA 0183**

Data from SeaTalk is transmitted to the **NMEA OUT** connector every 2 seconds. The supported NMEA output data is detailed in the following table.

Data	NMEA Header
Depth	DBT
Heading, deviation and variation	HDG
Magnetic heading	HDM
Water temperature	MTW
Wind speed and angle	MWW
Water speed and heading	VHW

NMEA to SeaTalk

When supported NMEA data is available at the **NMEA IN** connector, it is decoded and displayed by the ST60+ Graphic Display. The supported NMEA input data is detailed in the following table.

Data	NMEA Header
XTE, Waypoint identifier, Bearing & distance to waypoint	APB
Bearing & distance to waypoint	BWC
Bearing & distance to waypoint rhumb line	BWR
Latitude and longitude	GLL
Time, latitude, longitude, satellites tracked & HDOP	GGA
Cross track error	MWV or XTE
Navigational information	RMB
Time, date, lat, long, COG & SOG	RMC
COG and SOG	VTG

3.4 Starting procedures

Switching on

Switch on the power to your ST60+ instrument. When the power is on, you can use the  button to switch the instrument on and off as described in *Chapter 1, Operation*.

Use the procedures in *Chapter 1, Operation* to set the backlighting and contrast to the levels you want.



WARNING: Calibration requirement

To ensure this product performs at its best on your boat, you **MUST** calibrate it before use, in accordance with the instructions in *Chapter 4, Calibration*. Do NOT use the product until you have successfully calibrated it.

Defining the NMEA OUT connector function



If a connection is made to the **NMEA OUT** connector, you must use the procedures below to define how the **NMEA OUT** connector is to be used (i.e. for **either** NMEA out data **or** Auxiliary Alarm), before the ST60+ Graphic Display is used.:

1. Hold down the and buttons for approximately 2 seconds so that the User calibration entry screen is displayed.

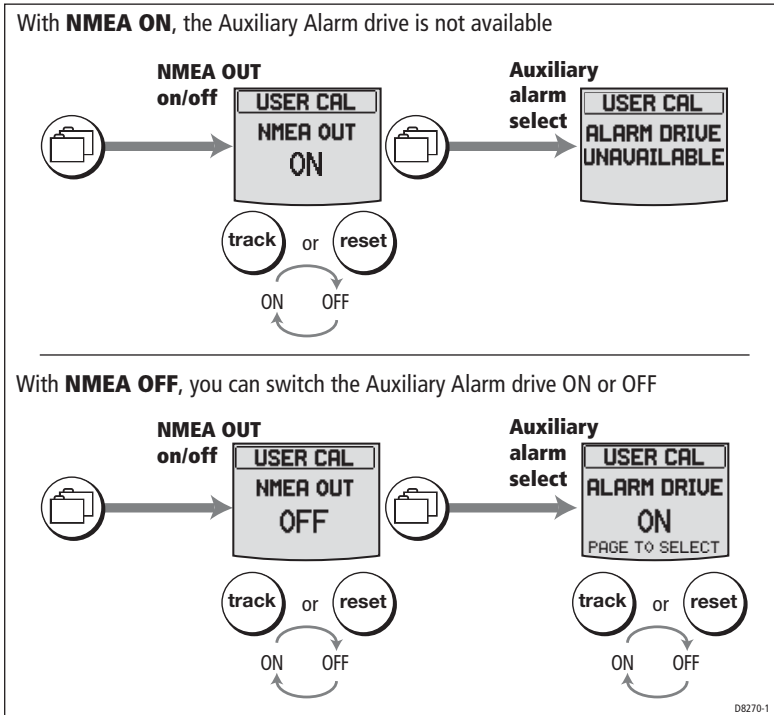
Note: *The User calibration entry screen will time out to the main display after 7 seconds, if you do not proceed.*



2. Press the button to enter User calibration.

3. Use the  button to go to the NMEA OUT on/off screen.
4. Use the **track** or **reset** button to switch the NMEA OUT function ON or OFF, as required. If you set:
 - NMEA ON, then the Auxiliary Alarm output is disabled and the Auxiliary Alarm Select screen (the next screen) shows ALARM DRIVE UNAVAILABLE .
 - NMEA OFF, then the Auxiliary Alarm output is available, and you can switch the Auxiliary Alarm drive ON or OFF at the Auxiliary Alarm Select screen, using the **track** or **reset** buttons.
5. When you have set NMEA OUT and ALARM DRIVE as required, hold down the  and  buttons for approximately 2 seconds to return to normal operation.

EMC conformance

Always check the installation before going to sea to make sure that it is not affected by radio transmissions, engine starting etc.

Chapter 4: Calibration

4.1 Introduction

Use this chapter to set up and check the ST60+ Graphic Display, before it is used operationally. Instructions are given to enable you to:

- Define the function of the **NMEA OUT** connector (see *Chapter 1, System Connections*).
- Carry out Dealer calibration.
- Check basic operation.



4.2 User calibration

A User calibration facility enables you to:



- Set the Favorite page rollover period, or switch the rollover off.
- Switch chapter titles on or off.
- Set whether headings are displayed in true or magnetic form.
- Set the voltage at which a battery alarm will occur.
- Enable/disable individual local alarms.
- Set the date format.
- Set the time format.
- Set the instrument time to local time.
- Select the units in which NMEA data are displayed.
- Select the function of the display **NMEA OUT** connector. This is either
 - A remote alarm output for the Auxiliary Alarm (NMEA OFF).
 - or
 - NMEA output signals.
- Enable/disable individual remote alarms.
- Enable/disable the pilot pop up display.
- Configure the instrument to display specific pages.

Procedure

To carry out the required setup procedure:

1. Hold down the  and  buttons for approximately 2 seconds so that the User calibration entry screen is displayed.

Note: *The User calibration entry screen will time out to the main display after 7 seconds.*

2. Press the  button to enter User calibration.
3. Referring to the *User calibration* diagram below, use the  button to cycle to the required screen, then set the required values as described below.

Favorite page rollover

Use the **track** or **reset** button to set the required Favorite page rollover period, from 0.5 SEC to 20 SEC. Press the **track** button to reduce the rollover period and the **reset** button to increase it.

If you want to be able to select Favorite pages manually as for other chapters, use the **track** button to reduce the value of the rollover until OFF is displayed.

Chapter titles

Use the **track** and **reset** buttons to select either:

- ON, so that each chapter title is briefly displayed when the chapter is selected during normal operation,
- or
- OFF, if you do not want chapter titles to be displayed.

Heading type

Use this to define how heading values are displayed. Use the **track** and **reset** buttons to select either magnetic (MAG) or true (TRUE). If a variation value is not available on SeaTalk, then MAG is selected permanently.

Battery alarm threshold

Use the **track** and **reset** buttons to set the required voltage alarm threshold, in the range 9 V to 14 V. Press the **track** button to reduce the level and the **reset** button to increase it.

The recommended value is 10.5 V.

If you want to switch off the battery alarm, Press the **track** button to reduce the level until OFF is displayed.

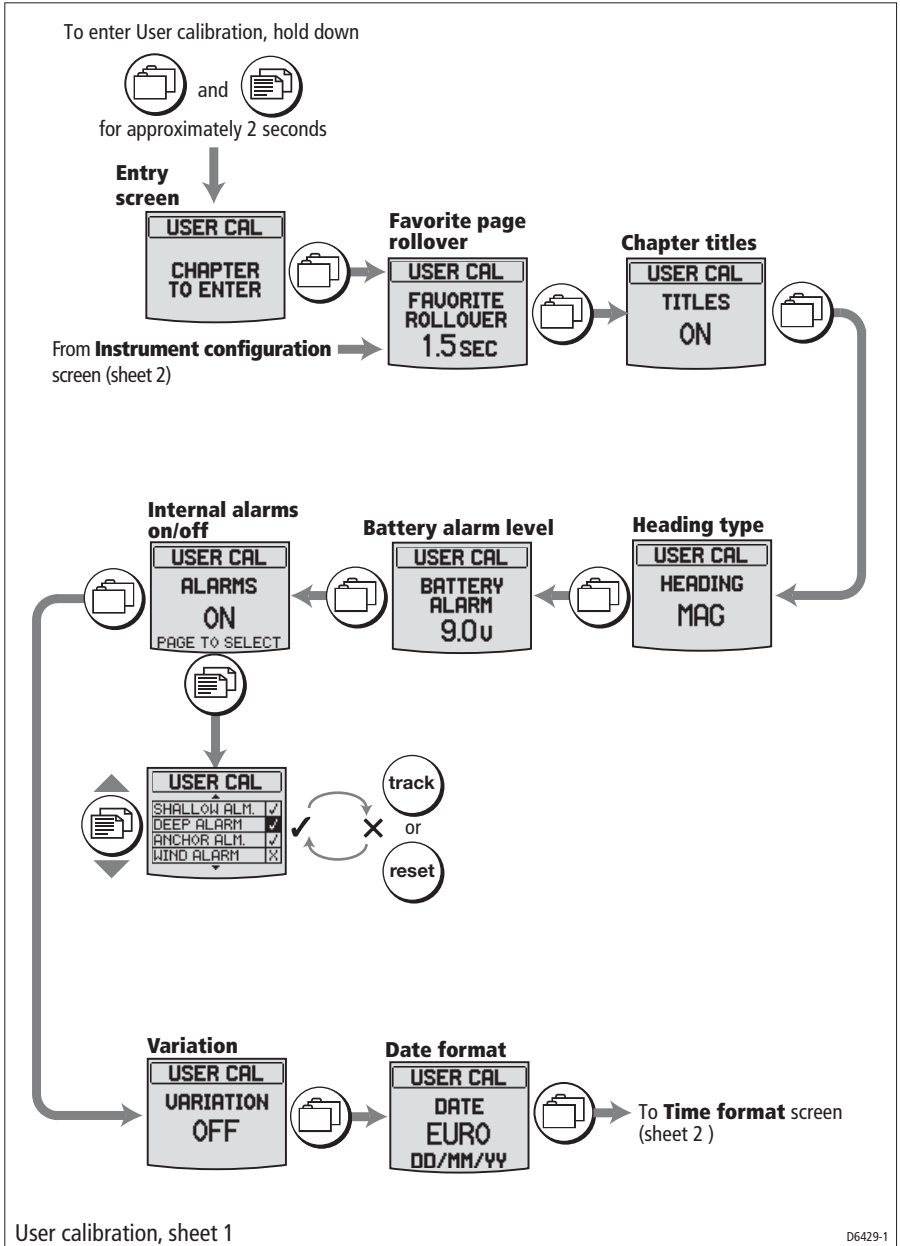

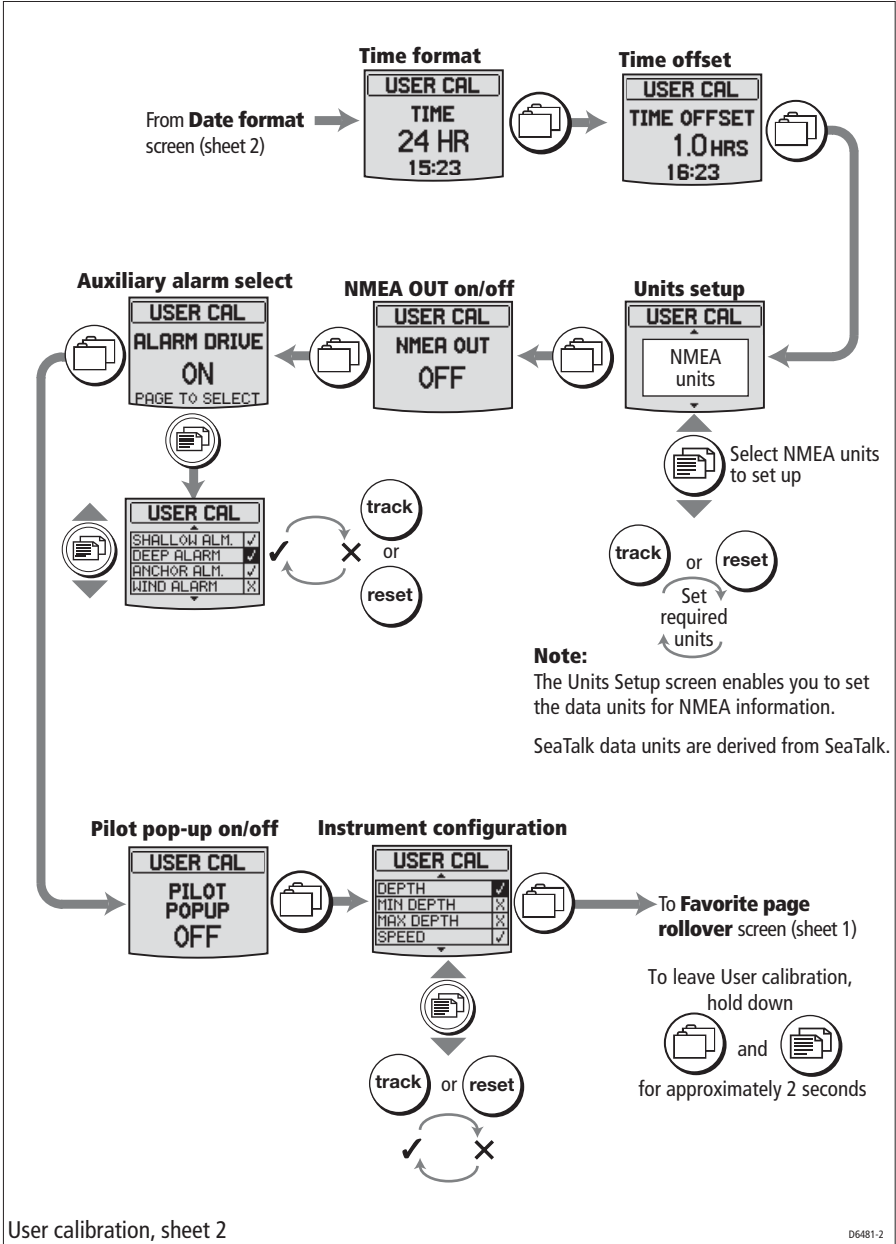



Internal alarms on/off

Use the **track** or **reset** button to set the internal ALARMS OFF if you do not want the ST60+ Graphic Display to give alarm indications. Otherwise, set ALARMS ON .

If you have set the ALARMS ON , set the individual internal alarms as follows:

1. Press the  button to display the list of alarms. The first alarm is highlighted, to indicate you can adjust it.
2. Use the **track** or **reset** button to either enable (✓) or disable (✗) the highlighted alarm.
3. Use the  button to move the highlight to each alarm in turn, and either enable or disable it, as described in step 2.

Note: *External alarms (see Auxiliary Alarm select below) will occur, irrespective of the internal alarm settings.*

Variation

If an external magnetic variation value is available from SeaTalk or NMEA, this will be used by the ST60+ Graphic Display.

If an external variation input is not available, use the  button to set VARIATION ON , then use the **track** and **reset** buttons to set the correct magnetic variation value.

If you do not want to display the variation value, use the  button to set VARIATION OFF .

Date format

Use the **track** or **reset** button to select the required date format. Either United States (MM/DD/YY) or European (DD/MM/YY).

Time format

Use the **track** or **reset** button to select either 12-hour or 24-hour time format.

Time offset

Use the **track** or **reset** button to apply an appropriate offset to set your system time to local time. You can set any offset in the range -12 hours to +12 hours, in half-hour increments. The time with the offset applied is shown at the bottom of the screen.

Units setup

The units in which SeaTalk data is displayed, are determined by the respective master instruments. However, as the ST60+ Graphic Display can also display NMEA data, the Units setup screen enables you to set the units for this data.

Setting units

With the Units setup screen displayed, use the  button to move to each data type in turn and for each, use the **track** or **reset** button to select the required unit.

NMEA OUT on/off

The NMEA OUT on/off screen enables you to set which function the **NMEA OUT** connector provides. This is either:

- NMEA data out.
- or
- Alarm signals for the Auxiliary Alarm.

If want to output NMEA data, use the **track** or **reset** button to select NMEA OUT ON . If you want to output alarm signals to the Auxiliary Alarm, select NMEA OUT OFF .

Auxiliary Alarm select

Use the ALARM DRIVE screen to determine which alarms you want to sound at the Auxiliary Alarm.

Note: *The NMEA OUT function must be OFF, to enable the Auxiliary Alarm to be used.*

Use the **track** or **reset** button to set ALARM DRIVE OFF, if you do not want any alarms to sound at the Auxiliary Alarm. Otherwise, set ALARM DRIVE ON

If you have set ALARM DRIVE ON, use the  button to move to each alarm in turn and for each, use the **track** or **reset** button to either enable (✓) or disable (✗) the alarm.

Pilot pop-up

Use the **track** or **reset** button to set the PILOT POPUP either ON or OFF, as required.

Instrument configuration

You can streamline the operation of the instrument by defining which pages are available for display on a day-to-day basis, and switching off pages you do not wish to see.

Use the Instrument configuration page to define which pages are available during normal operation, as follows:



1. Use the  button to cycle through the pages. Each page is identified by a coded title, as detailed in the table below.
2. As each page is displayed, use the **track** and **reset** buttons to toggle the page ON or OFF.

Title	Page affected	Chapter
DEPTH	Current depth	Depth
MIN DEPTH	Minimum depth	Depth
MAX DEPTH	Maximum depth	Depth
DEPTH GRAPH	Depth graph	Depth
SPEED	Boat speed	Speed
MAX SPEED	Maximum speed	Speed
AVG SPEED	Average speed	Speed
SOG	Speed over ground	Speed
SPD & SOG	Speed and speed over ground	Speed
VMG TO WIND	Velocity made good to windward	Speed
TRIP LOG	Log and trip log	Speed
RACE TIMER	Race timer	Speed
SPEED GRAPH	Speed graph	Speed
A WIND SPEED	Apparent wind speed	Wind
A WIND ANGLE	Apparent wind angle	Wind
T WIND SPEED	True wind speed	Wind
T WIND ANGLE	True wind angle	Wind
GROUND WIND	True wind direction (over ground)	Wind
WIND FORCE	Beaufort/cardinal	Wind
AWS GRAPH	Apparent wind speed graph	Wind

Title	Page affected	Chapter
AWA GRAPH	Apparent wind angle graph	Wind
TWS GRAPH	True wind speed graph	Wind
TWA GRAPH	True wind angle graph	Wind
GWD GRAPH	Ground wind angle graph	Wind
HEADING	Current heading	Heading
LOCKED HDG	Locked heading	Heading
TACK COURSE	Tack heading	Heading
COG	Course over ground	Heading
HDG & COG	Course over ground and heading	Heading
CMG & DMG	Course made good and distance made good	Heading
HEAD GRAPH	Heading graph	Heading
BTW & DTW	Bearing to waypoint and distance to waypoint	Navigate
XTE	Cross track error	Navigate
WAYPOINT	Waypoint identity	Navigate
POSITION	Latitude/longitude	Navigate
COG & SOG	Course over ground and speed over ground	Navigate
COG & BTW	Course over ground and bearing to waypoint	Navigate
GPS INFO	Satellites and HDOP	Navigate
TIDE INFO	COG, heading, SOG and speed	Navigate
ROLLING ROAD	Rolling road	Navigate
VMG TO WP	Velocity made good towards waypoint	Navigate
SEA TEMP	Sea temperature	Environment
BATTERY	Battery voltage	Environment
TIME & DATE	Time and date	Environment
S. TEMP GRAPH	Sea temperature graph	Environment

Title	Page affected	Chapter
VOLTS GRAPH	Battery voltage graph	Environment
PILOT STATUS	Pilot status	Pilot
RUDDER ANGLE	Rudder Angle	Pilot
FAVORITE 1	Favorite page 1	Favorite
FAVORITE 2	Favorite page 2	Favorite
FAVORITE 3	Favorite page 3	Favorite
FAVORITE 4	Favorite page 4	Favorite
FAVORITE 5	Favorite page 5	Favorite
FAVORITE 6	Favorite page 6	Favorite
FAVORITE 7	Favorite page 7	Favorite

Leaving User calibration

Hold down the  and  buttons for 2 seconds, to save your settings, exit User calibration and resume normal operation.

4.3 Dealer calibration

Summary

The Dealer calibration procedures enable you to set:

- Access to User calibration on/off.
- Response settings for speed, depth heading wind angle, wind speed, VMG, course over ground and speed over ground.
- The correct battery voltage reading.

Dealer calibration also gives access to:

- A default reset screen. This enables you to re-apply the factory settings if you want to reset the instrument to a known operating condition.
- A self-test entry screen.

Procedure

To carry out Dealer calibration:

1. Hold down the and buttons together for approximately 12 seconds, to select the Dealer calibration entry page (see *Dealer calibration* diagram).
2. Press the **track** and **reset** buttons together, to start Dealer calibration.
3. Referring to the Dealer calibration diagram below, use the button to cycle to each screen in turn, and set the appropriate values as described below.

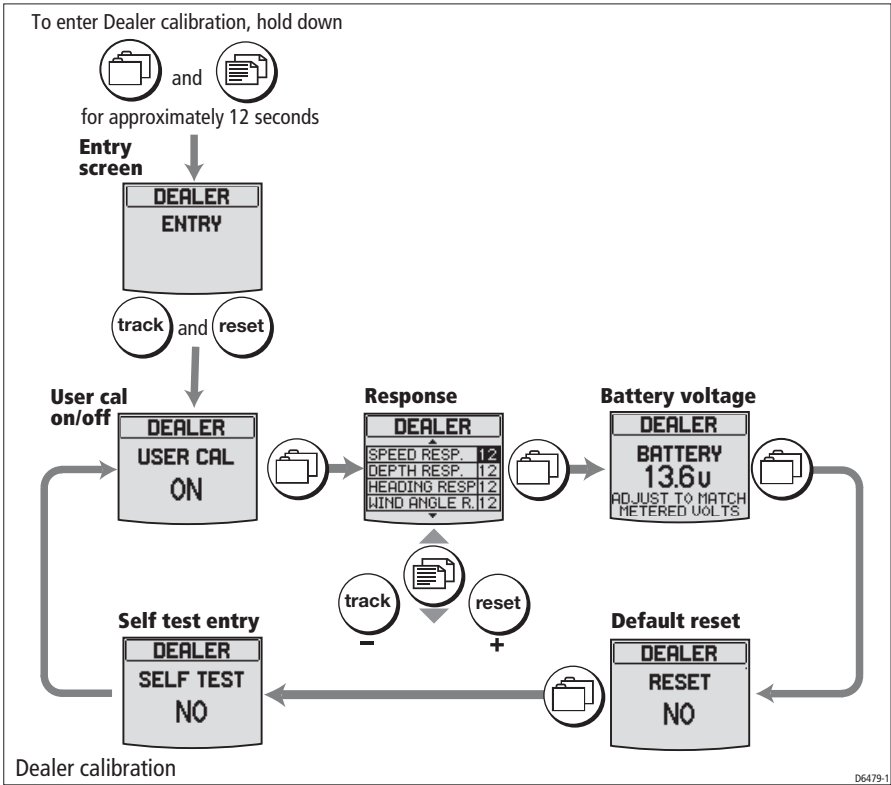

User calibration on/off

Press the **track** or **reset** button to toggle the User calibration either ON or OFF as required.

Note: *If at any time, you want to access the software version and serial number, you need to set User calibration ON.*

Response settings

The response values determine the sensitivity of the display to data changes. You can set each response value from 1 to 15. A low number provides a smooth response and a high number a much livelier response.

Use the  button to select the response you want to set, then use the **track** (decrement) and **reset** (increment) buttons to set the required value.

You can set responses for the following data:

- Speed (SPEED RESP.)
- Depth (DEPTH RESP.)
- Heading (HEADING RESP.)
- Wind angle (WIND ANGLE R.)
- Wind speed (WIND SPEED R.)
- Cross track error (XTE RESP.)

Battery voltage

Use the BATTERY screen to set the voltage reading at the ST60+ Graphic Display to be the same as the actual supply voltage from the boat's electrical system.



WARNING: HIGH VOLTAGE HAZARD

High voltages can cause death or serious injury. Always take appropriate precautions when working with electricity. Before accessing the electrical system, ensure you know the location of high voltage points and stay well clear of them.

To set the voltage reading at the ST60+ Graphic Display:

1. With the BATTERY screen displayed, measure the 12 V supply voltage at the battery.
2. At the ST60+ Graphic Display, use the **track** or **reset** button to set the displayed voltage to the same value as the measured voltage.

Default reset

You can use this screen to reset the operating parameters to the factory default values. Use the **track** and **reset** buttons to make the required selection.

Note that the selection you make at this screen will be applied when you exit the screen, so be sure you make the correct selection.

To retain the current values, ensure that the display shows NO.

If you want to apply the factory defaults, change the display to YES. If you do this, the values you have set up will be overwritten by the factory defaults when you leave this screen.

The factory default values are as follows:

Parameter	Factory default
Last display	Speed
Heading	Magnetic
Temperature units	Degrees Celsius
Depth units	Feet
Speed units	Knots
Wind speed units	Knots
Variation	None
Alarms	All enabled
User calibration	Enabled
Depth response	12
Speed response	12
Heading response	12
Wind angle response	12
Wind speed response	12
VMG response	12
COG/SOG response	12
Alarm control	On
NMEA	Off
Auxiliary alarms	All off
Low voltage threshold	Off
Display contrast	40
Pilot pop-up	Off
Waypoint identity	Name
Time offset	0 (zero)
Chapter titles	On



Parameter	Factory default
Remote group	None
Remote sequence	None

Self test

Self test is intended for engineers engaged in diagnostic procedures. Always set this to NO .

Note: *If YES is selected, you could inadvertently initiate a self test routine. This will not harm the product but will interrupt operation, so it is therefore NOT recommended.*

Leaving Dealer calibration

Hold down the  and  buttons for 2 seconds to save your settings and exit Dealer calibration.

4.4 Checking operation

When installation and calibration are complete, check that the ST60+ Graphic Display performs satisfactorily by carrying out basic checks and NMEA checks, before operational use.

Basic checks

Ensure that the display shows the appropriate chapters and pages, as described in *Chapter 1, Operation* . When doing this, be aware that some data types may not be supported by your system and therefore will not be displayed on your ST60+ Graphic Display. If you think that data is missing, ensure that your system supports this data before assuming that a fault exists.

NMEA checks

Ensure that the display operates satisfactorily with any NMEA equipment to which it is connected.

Glossary

APP	Apparent
AVE	Average
AWA	Apparent Wind Angle (relative to the vessel)
AWS	Apparent Wind Speed
BTW	Bearing To Waypoint
CMG	Course Made Good
COG	Course Over Ground
DMG	Distance Made Good
DTW	Distance To Waypoint
EMC	Electro Magnetic Compatibility
ETA	Estimated Time of Arrival
GPS	Global Positioning System
HDG	Heading
KM	Kilometer(s)
KMH	Kilometers per hour
KTS	Knot(s)
LAT	Latitude
LCD	Liquid Crystal Display
LON	Longitude
LTR	Liter(s)

M	Magnetic or meters
MAG	Magnetic
MOB	Man Overboard
MPH	Miles per hour
NM	Nautical mile(s)
Response	The sensitivity of an instrument, to data changes.
RF	Radio Frequency
SeaTalk	Raymarine proprietary communication system which links products, to provide a single, integrated system sharing power and data.
SM	Statute mile(s)
SOG	Speed Over Ground
SPD	Speed
T	True
TTG	Time To Go
TWA	True Wind Angle relative to the vessel, taking into account the speed of the vessel.
TWD	True Wind Direction.
TWS	True Wind Speed.
VMG	Velocity Made Good.
WP	Waypoint
XTE	Cross Track Error

Index

A

Alarms

- Auxiliary Alarm
 - setup, 40
- external, 12
- internal, 12
 - setup, 39
- silencing, 12

Autopilot pages, 9

Autopilot pop-up setup, 40

Autopilot status, 11

Auxiliary Alarm, 12

- setup, 40

Auxiliary Alarm connections, 29

B

Backlighting adjustment, 13

Battery alarm setup, 36

C

Calibration requirement, 31

Changing timescales on graphs, 4

Chapter titles, 3

- switching on/off, 36

Chapters & pages

- Autopilot, 9
- Depth, 5
- enable/disable pages, 40
- Environment, 9
- Heading, 7
- Navigate, 8
- Speed, 6
- Wind, 6

Checking operation, 47

Cleaning, 15

Clock setup, 39

Condensation, 15

Connections

- Auxiliary Alarm, 29
- mandatory, 27
- NMEA, 29
- optional, 27

Contrast adjustment, 14

Customizing the display, 35

- Auxiliary Alarm, 40

chapter titles, 36

clock, 39

date format, 39

enable/disable pages, 40

Favorite pages, 36

internal alarms, 39

NMEA OUT function, 40

pilot pop-up, 40

selecting heading type, 36

setting battery alarm, 36

time format, 39

units, 40

variation, 39

D

Data units setup, 40

Date format setup, 39

Dealer calibration

- default reset, 45
- enable/disable User cal, 44
- setting responses, 45
- setting voltage reading, 45

Default settings, 45

Depth pages, 5

Display setup, 35

Disposing of the product, ii

E

EMC information, i, 20, 33

Environment pages, 9

F

Factory defaults, 45

Favorite pages

- setting up displayed data, 10
- setting up the rollover, 36

G

Graphs, 4

H

Heading pages, 7

Heading type

- selecting magnetic or true, 36

Help lines, 17

I

Initial checks, 47

Installing

instrument

 bracket mounting, 26

 flush mounting, 23

 power supply connections, 28

 requirements, 19

 signal connections, 29

 surface mounting, 22

 planning, 19

Instrument mounting options, viii

M

Mounting options (instrument), viii

N

Navigate pages, 8

NMEA connections, 29

NMEA OUT

 setting function, 32

 uses, 29

NMEA OUT setup, 40

NMEA supported data, 30

P

Parts supplied, ix–x

Product disposal, ii

R

Remote control, viii

Reset defaults, 45

Rolling road, 4

S

Safety, 15

 calibration requirement, 31

 electrical, i

 general, i

 navigation, i

SeaTalk overview, vii

Setting up

 Auxiliary Alarm, 40

 chapter titles, 36

 clock, 39

 date format, 39

 display responses, 45

 enable/disable pages, 40

 Favorite pages, 36

 internal alarms, 39

 NMEA OUT function, 32, 40

 pilot pop-up, 40

 selecting heading type, 36

 setting battery alarm, 36

 time format, 39

 units, 40

 User calibration on/off, 44

 variation, 39

 voltage reading, 45

Silencing alarms, 12

Site requirements

 instrument, 19

Software version, 17

Speed pages, 6

Switching on/off, 1, 31

T

Technical support, 16

Time format setup, 39

Troubleshooting, 16

U

User calibration, 35

 Auxiliary Alarm setup, 40

 chapter titles, 36

 date format, 39

 enable/disable, 44

 enable/disable pages, 40

 Favorite pages, 36

 internal alarms, 39

 pilot pop-up, 40

 selecting heading type, 36

 setting battery alarm, 36

 setting clock, 39

 setting NMEA OUT function, 40

 setting units, 40

 time format, 39

 variation, 39

V

Variation, 39

W

Wind pages, 6

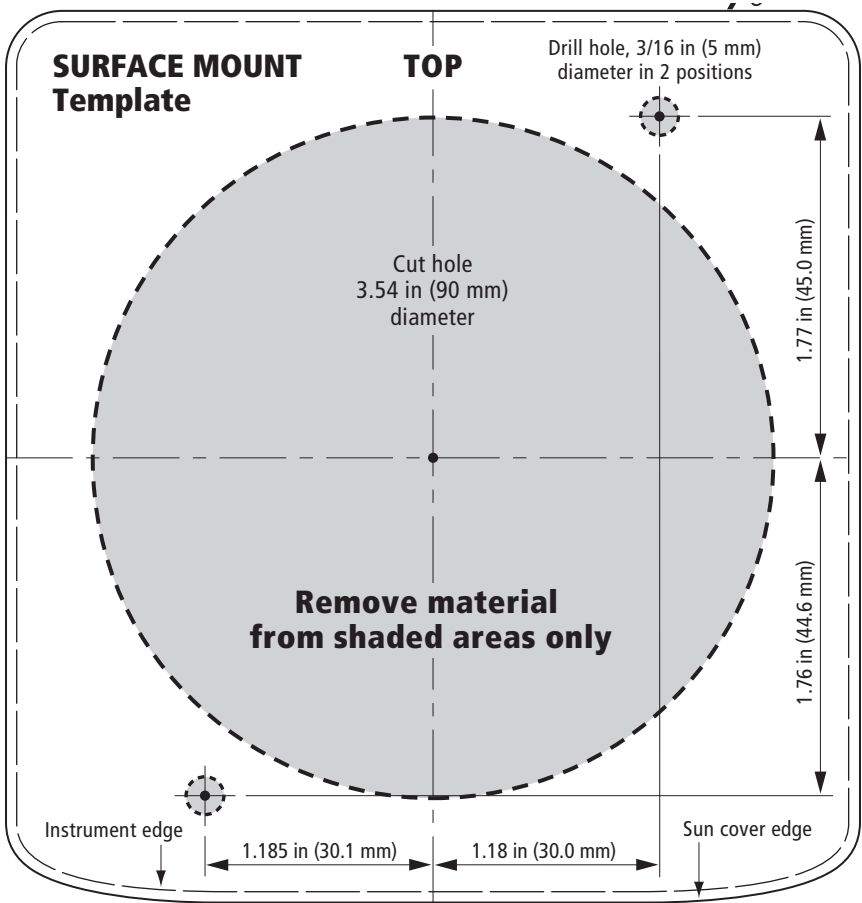

SURFACE MOUNT template for ST60+ Instruments

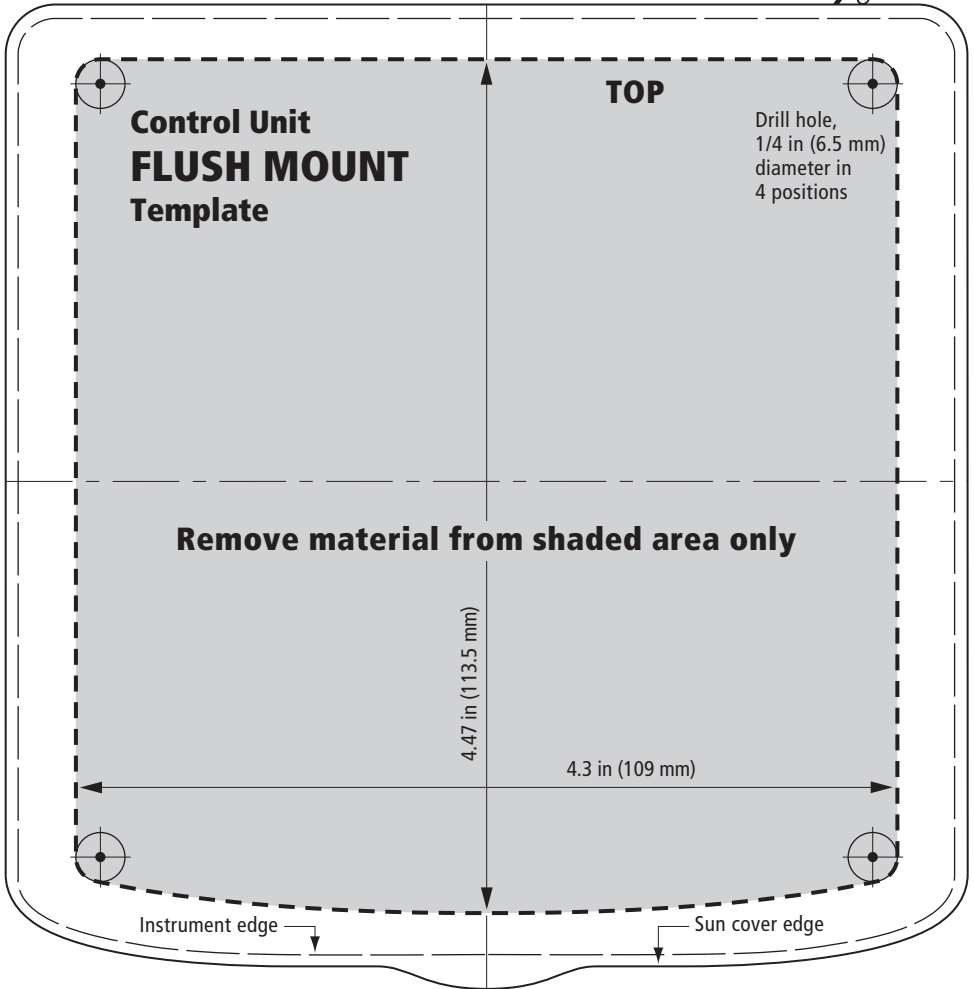

**FLUSH MOUNT template for
ST60+ Instruments**

