

Distributed by
Raymarine

Any reference to Raytheon or RTN in this manual should be interpreted as Raymarine. The names Raytheon and RTN are owned by the Raytheon Company.

Autohelm

ST80 Active Wind Transducer

Installation

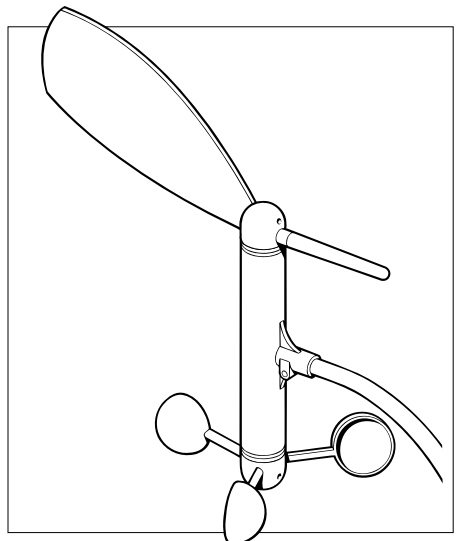



Package Contents

1. Mounting base
2. Transducer arm
3. Wind vane head and balance weight
4. Anemometer head
5. SeaTalk cable
6. Installation manual
7. Warranty card
8. 3-way SeaTalk connector block
9. Cable clamp
10. Scotchlock connectors (3)
11. Screws (2)
12. Screws (4)
13. Screws (4)
14. Nut (4)
15. Hexagon keys (2)

Contents

- Chapter 1: Installation 3**
 - 1.1 Introduction 3
 - Components 3
 - Tools 3
 - 1.2 Installing the Transducer 4
 - Procedures 4
 - SeaTalk Cable Through the Top of the Mast 5
 - Cable Through the Side of the Mast 6
 - Joining the SeaTalk Cable 7
 - 1.3 Connecting the Transducer to SeaTalk 7
 - 1.4 Connecting the Power Supply 8
- Chapter 2: EMC and Servicing Guidelines 9**
 - 2.1 Important information 9
 - 2.2 Installation 9
 - 2.3 Check Before Going to Sea 10
 - 2.4 Servicing and Safety 10
- Chapter 3: Specification 11**

Chapter 1: Installation

1.1 Introduction

This chapter describes how to install the Active Wind Transducer using everyday hand tools.

Before you begin, make sure that you have all the necessary components, templates and the correct tools for the job.

Components

- Active wind transducer and mounting components
- Vane and anemometer
- 30m or 50m (97.5ft or 162ft) length of SeaTalk cable (part numbers D252 and D253 respectively)
- Paper template
- Scotchlock connectors

Tools

- 1.5mm hexagonal key
- 5mm drill bit
- 6mm tap and tap wrench
- Power drill
- Pliers
- Screwdrivers

1.2 Installing the Transducer

General Points to Remember...

- The head of the transducer should be pointing forwards.
- If your vessel has an angular mast top, use a block to eliminate this angle.

Procedures

1. Assemble the anemometer and wind vane to the transducer head.

- (1) Wind vane
(2) Transducer head
(3) Anemometer

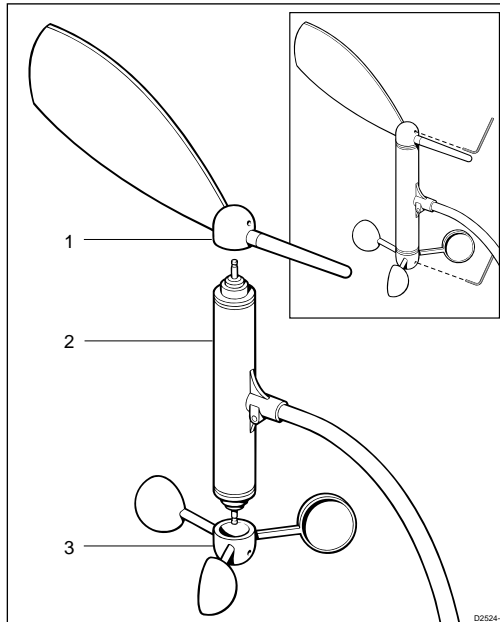

2. Use the 1.5mm hexagon key to tighten the anemometer and wind vane grub screws (see inset diagram).
3. Apply the template to the top of the mast so that the arrow points towards the bow.
4. Drill four 5mm holes into/through the top of the mast.
5. Cut the threads for these holes using a 6mm tap.

6. The 30m (97.5ft) or 50m (162ft) SeaTalk cable is supplied with SeaTalk connectors at both ends. To run this cable down the inside of the mast, the larger (flat) connector must be cut off. **Make sure that you leave sufficient cable attached to this connector for rewiring.**
7. Assemble the active wind transducer to the top of the mast so that the SeaTalk cable goes through the top (or side) of the mast mounting base.

SeaTalk Cable Through the Top of the Mast

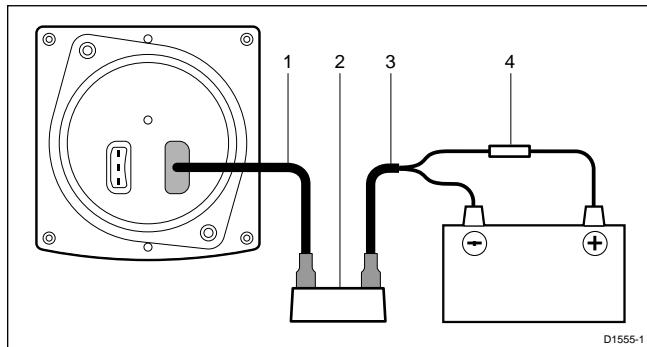

Note: The SeaTalk cable plugs into the 3-pin male connector inside the active transducer arm.

Cable Through the Side of the Mast

- (1) Active wind transducer arm
- (2) Bayonet coupling
- (3) O'ring
- (4) Female SeaTalk connector
- (5) Socket head screws
- (6) Mounting base
- (7) SeaTalk cable

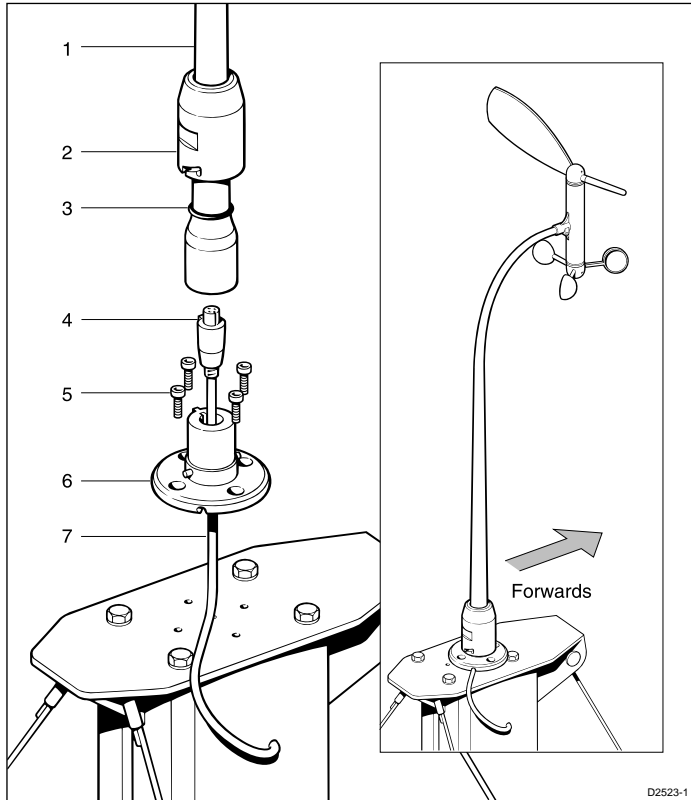

Once the mounting base has been attached to the mast top, secure the transducer arm to the base using the bayonet coupling. Twist the coupling until the location pins lock into position.

Note: A wrench may be required to turn the bayonet coupling.

Joining the SeaTalk Cable

Use a pair of pliers and the 3 “Scotchlock” connectors to rejoin the SeaTalk cable colour-for-colour.

- (1) SeaTalk connector
- (2) "Scotchlock" connectors
- (3) SeaTalk cable

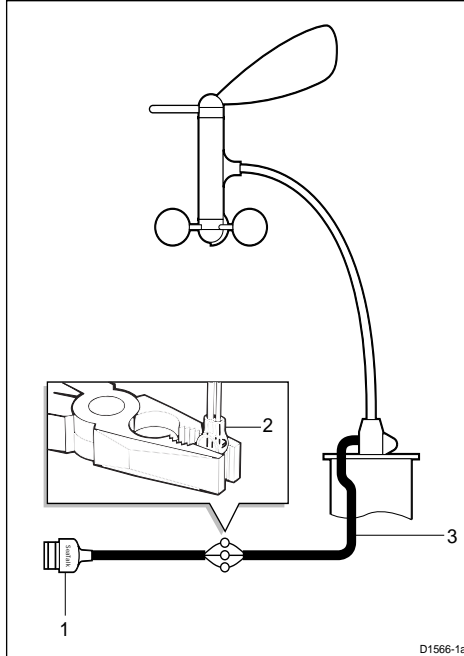

1.3 Connecting the Transducer to SeaTalk

Plug the SeaTalk cable into any ST80 3-way SeaTalk connector block or display head.

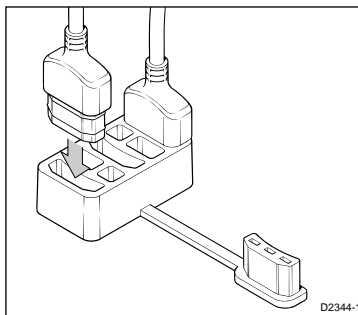

If a 3-way SeaTalk connector block has not already been fitted, secure the block to a suitable bulkhead using the 16mm (5/8in) self-tapping screws.

The following diagram shows a typical SeaTalk system and the method of inter-unit connection.

- (1) ST80 display head
- (2) Inter unit cable
- (3) SeaTalk3-way connector block
- (4) Power cable
- (5) SeaTalk cable
- (6) Mast top

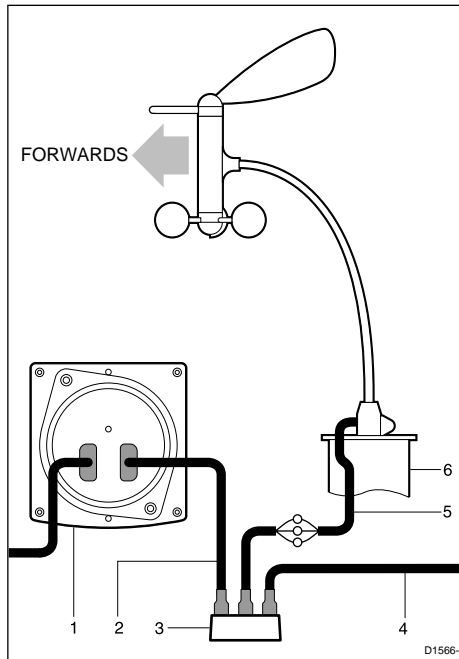

1.4 Connecting the Power Supply

If you have not already connected your SeaTalk system to the power supply, use the supplied 2m (6ft) power cable to do so.

Attach the red (+) and screen (-) wires to the positive (+) and negative (-) battery terminals. The positive line should also be fitted with a 5A fuse/circuit breaker.

- (1) Standard SeaTalk cable
- (2) SeaTalk 3-way connector block
- (3) Power cable
- (4) 5A fuse or circuit breaker

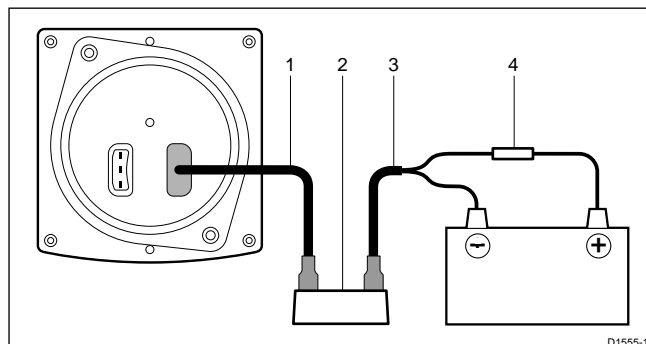

Chapter 2: EMC and Servicing Guidelines

2.1 Important information

All Autohelm equipment and accessories are designed to the best industry standards for use in the leisure marine environment.

Their design and manufacture conforms to the appropriate Electromagnetic Compatibility (EMC) standards, but good installation is required to ensure that performance is not compromised. Although every effort has been taken to ensure that they will perform under all conditions, it is important to understand what factors could affect the operation of the product.

2.2 Installation

To avoid the risk of operating problems, all Autohelm equipment and cables connected to it should be:

- At least 1m (3 feet) from any equipment transmitting or cables carrying radio signals, e.g., VHF radios, cables and antennas. In the case of SSB radios, the distance should be increased to 2m (7ft).
- More than 2m (6ft) from the path of a radar beam. A radar beam can normally be assumed to spread 20 degrees above and below the radiating element.
- The equipment should be supplied from a different battery than the one used for engine start. Voltage drops below 10V in the power supply to our products can cause the equipment to reset. This will not damage the equipment, but will cause the loss of some information and can change the operating mode.
- Genuine Autohelm cables should be used at all times. Cutting and rejoining these cables can compromise EMC performance and so should be avoided unless doing so is detailed in the installation manual.
- If a suppression ferrite is attached to a cable, this ferrite should not be removed. If the ferrite has to be removed during installation it must be reassembled in the same position.

2.3 Check Before Going to Sea

- Always check the installation before going to sea to make sure that it is not affected by radio transmissions, engine starting etc..
- In some installations, it may not be possible to prevent the equipment from being affected by external influences. In general this will not damage the equipment but can lead to it resetting, or momentarily may result in faulty operation.

2.4 Servicing and Safety

- Autohelm equipment should be serviced only by authorised Autohelm service engineers. They will ensure that service procedures and replacement parts used will not affect performance. There are no user serviceable parts in any Autohelm product.
- Some products generate high voltages, and so never handle the cables/connectors when power is being supplied to the equipment.
- Always report any EMC related problem to your nearest Autohelm dealer. We will use any such information to improve our quality standards.

Chapter 3: Specification

Construction:	Shaft: Carbon fibre Vane/anemometer: Plastic Base and balance weight: Steel
Dimensions:	Height: 912mm (36in) Base to end of balance weight: 296mm (11.5in)
Power supply:	10 to 16V
Current consumption:	30 mA
Wind speed range:	0 to 100 knots
Wind angle range:	0 to 359.9°



Raytheon Marine Europe Ltd.
Anchorage Park, Portsmouth,
P03 5TD, England.
Telephone: (44) (0) 2392 693611
Fax: +44 (0) 2392 694642

Autohelm
