



Heading Sensor

Owner's Handbook

Document number: 81124_3
Date: 1st May 2001





Copyright © Raymarine Limited 2001





Important information

WARNING

Although your Heading Sensor is designed to give accurate and reliable performance, it should serve only as an aid to navigation and should never lead to the erosion of good seamanship. Always maintain a permanent watch and be aware of situations as they develop.

EMC conformance

All Raymarine equipment and accessories are designed to the best industry standards for use in the leisure marine environment.

The design and manufacture of Raymarine equipment and accessories conform to the appropriate Electromagnetic Compatibility (EMC) standards, but correct installation is required to ensure that performance is not compromised.

Handbook information

To the best of our knowledge, the information in this handbook was correct when it went to press. However, the Raymarine policy of continuous product improvement may change product specifications without notice. Consequently, unavoidable differences may occur between the product and the handbook from time to time, for which Raymarine cannot accept liability





Contents

- Important information i**
 - WARNING i
 - EMC conformance i
 - Handbook information i
- Chapter 1: Introduction 1**
 - 1.1 Handbook information 1
 - 1.2 Description 1
- Chapter 2: Maintenance & Fault Finding 3**
 - 2.1 Servicing and Safety 3
 - 2.2 Maintenance 3
 - 2.3 Fault Finding 4
 - Assistance 4
- Chapter 3: Installation 5**
 - 3.1 Before you Begin 5
 - Components 5
 - Basic Installation Tools 5
 - EMC Installation Guidelines 5
 - Suppression Ferrites 6
 - Connections to Other Equipment 7
 - 3.2 Siting the Heading Sensor 7
 - 3.3 Installation Procedure 8
 - 3.4 Connection Procedure 9





Chapter 4: Calibration 11

 4.1 Introduction 11

 EMC Conformance 11

 4.2 Continuous Deviation Correction 11

 4.3 Heading Alignment 12

Heading Sensor Specification 15



Chapter 1: Introduction

Thank you for purchasing a Raymarine product. We are sure your Heading Sensor will give you many years of trouble-free operation.

This Heading Sensor is designed to provide reliable performance, even under the most demanding conditions.

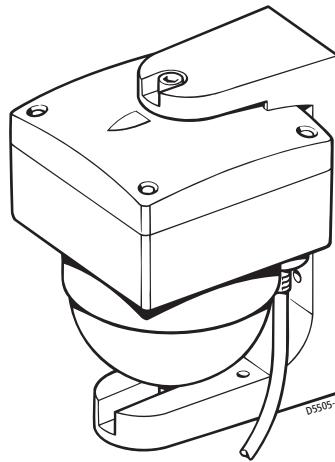

1.1 Handbook information

This handbook contains important information on the installation, calibration and maintenance of your Heading Sensor. Please read the handbook thoroughly, so that you get the best results from this product.

1.2 Description

The Raymarine Heading Sensor consists of an oil-filled sphere suspended in a custom built “swing bracket”, together with associated electronics.

The Heading Sensor transmits magnetic compass heading data to equipment that is NMEA 0183 compatible, such as radars, RayData displays, and RayPilot autopilot systems.



Chapter 2: Maintenance & Fault Finding

2.1 Servicing and Safety

- Raymarine equipment should be serviced only by authorized Raymarine service technicians. They will ensure that service procedures and replacement parts used will not affect performance. There are no user serviceable parts in any Raymarine product.
- Some products generate high voltages, so never handle the cables/connectors when power is being supplied to the equipment.
- When powered up, all electrical equipment produces electromagnetic fields. These can cause adjacent pieces of electrical equipment to interact with one another, with a consequent adverse effect on operation. In order to minimise these effects and enable you to get the best possible performance from your Raymarine equipment, guidelines are given in the installation instructions, to enable you to ensure minimum interaction between different items of equipment, i.e. ensure optimum Electromagnetic Compatibility (EMC).
- Always report any EMC-related problem to your nearest Raymarine dealer. We use such information to improve our quality standards.
- In some installations, it may not be possible to prevent the equipment from being affected by external influences. In general this will not damage the equipment but it can lead to spurious resetting action, or momentarily may result in faulty operation.
- Always switch off the power to Raymarine equipment before working on it.

2.2 Maintenance

The Raymarine Heading Sensor is a sealed unit. Maintenance procedures are therefore limited to the following periodical checks:

- Examine the cable for signs of damage, such as chafing, cuts or nicks
- Make sure that the Heading Sensor is still attached securely to the bulkhead

2.3 Fault Finding

All Raymarine products are subjected to comprehensive test and quality assurance programmes, prior to packing and shipping. However, if your Heading Sensor should develop a fault, please refer to the following table to identify the most likely cause and the corrective action required to restore normal operation.

Problem	Correction
No compass heading data available.	Check that the cable connecting the Heading Sensor to the NMEA instrument or system is firmly attached and undamaged.
The compass heading displayed on the associated instrument is not the same as the ship's compass.	Heading Sensor has not been linearised.
Linearisation procedure unsuccessful.	Move the Heading Sensor to a new location and try again.

Assistance

If you still have a problem after referring to the table above, contact your local dealer or Raymarine Product Support Department for further advice.

Chapter 3: Installation

This chapter describes how to install the Heading Sensor, using everyday hand tools.

3.1 Before you Begin

Before you begin, make sure that you have the all the required components and tools (listed below) to hand.

Note: *Before attempting any installation, you should read the Electromagnetic Compatibility (EMC) installation and service guidelines provided under EMC Installation Guidelines.*

Components

The Raymarine Heading Sensor includes the following standard components:

- Heading Sensor
- “Swing” bracket
- Self tapping screws (4)
- 6ft (2m) cable, with molded Heading Sensor plug on one end

If you are installing the Heading Sensor at a distance from an NMEA instrument or system, you may also need a 16.25ft (5m) NMEA accessory cable.

Basic Installation Tools

- Cross head screwdriver
- Electric/hand drill
- 1mm (0.39in) drill bit

EMC Installation Guidelines

All Raymarine equipment and accessories are designed to the best industry standards for use in the recreational marine environment.

Their design and manufacture conforms to the appropriate Electromagnetic Compatibility (EMC) standards, but correct installation is required to ensure that performance is not compromised.

Although every effort has been taken to ensure that they will perform under all conditions, it is important to understand what factors could affect the operation of the product.

The guidelines given here describe the conditions for optimum EMC performance, but it is recognized that it may not be possible to meet all of these conditions in all situations. To ensure the best possible conditions for EMC performance within the constraints imposed by any location, always ensure the maximum separation possible between different items of electrical equipment.

For **optimum** EMC performance, it is recommended that **wherever possible**:

- Raymarine equipment and cables connected to it are:
 - At least 3 ft (1 m) from any equipment transmitting or cables carrying radio signals e.g. VHF radios, cables and antennas. In the case of SSB radios, the distance should be increased to 7 ft (2 m).
 - More than 7 ft (2 m) from the path of a radar beam. A radar beam can normally be assumed to spread 20 degrees above and below the radiating element.
- The equipment is supplied from a separate battery from that used for engine start. Voltage drops below 10 V in the power supply to our products, and starter motor transients, can cause the equipment to reset. This will not damage the equipment, but may cause the loss of some information and may change the operating mode.
- Raymarine specified cables are used. Cutting and rejoining these cables can compromise EMC performance and must be avoided unless doing so is detailed in the installation manual.
- If a suppression ferrite is attached to a cable, this ferrite should not be removed. If the ferrite needs to be removed during installation it must be reassembled in the same position.

Suppression Ferrites

The following illustration shows typical cable suppression ferrites used with Raymarine equipment. Always use the ferrites supplied by Raymarine.

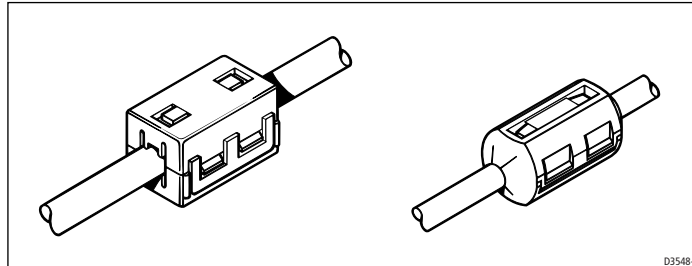

Connections to Other Equipment

If your Raymarine equipment is to be connected to other equipment using a cable not supplied by Raymarine, a suppression ferrite **MUST** always be attached to the cable near the Raymarine unit.

3.2 Siting the Heading Sensor

The Heading Sensor must be fitted to a vertical or horizontal bulkhead (preferably forward facing), away from large ferrous objects such as the engine and other magnetic devices.

If you have any doubts about the magnetic suitability of a chosen location, attach a hand bearing compass to the chosen site and then turn your vessel through 360°. Differences between the hand-bearing compass and the boat's compass should not exceed 10° on any heading.

The Heading Sensor should be positioned as close as possible to the pitch and roll centre of the vessel, as shown in the following diagram.

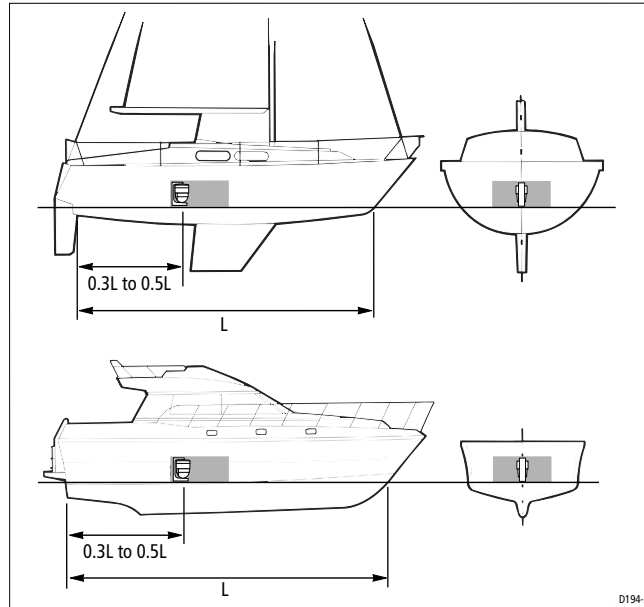

The compass is normally bulkhead mounted below decks. However, it can be mounted above deck on steel vessels. Although it is weatherproof, performance may be impaired due to the increased motion if it is mounted above deck.

3.3 Installation Procedure

To install the heading Sensor:

1. Hold the Heading Sensor mounting bracket (4) against the selected bulkhead.
2. Outline the four fixing holes in the Heading Sensor mounting bracket (4).
3. Drill four pilot holes for the self-tapping screws.
4. Secure the Heading Sensor mounting bracket (4) to the bulkhead using the four self-tapping screws (3) provided. The embossed arrow on the back of the bracket must be pointing skywards.

Note: *The Heading Sensor must be within 10° of the vertical and, ideally, positioned at the pitch and roll centre of the vessel.*

- Assemble the Heading Sensor (1) to the Heading Sensor mounting bracket (4). The shaft protruding from the base of the unit must click positively into the slot in the base of the mounting bracket.

Note: *The boat symbol embossed on the top of the active compass should be facing forwards.*

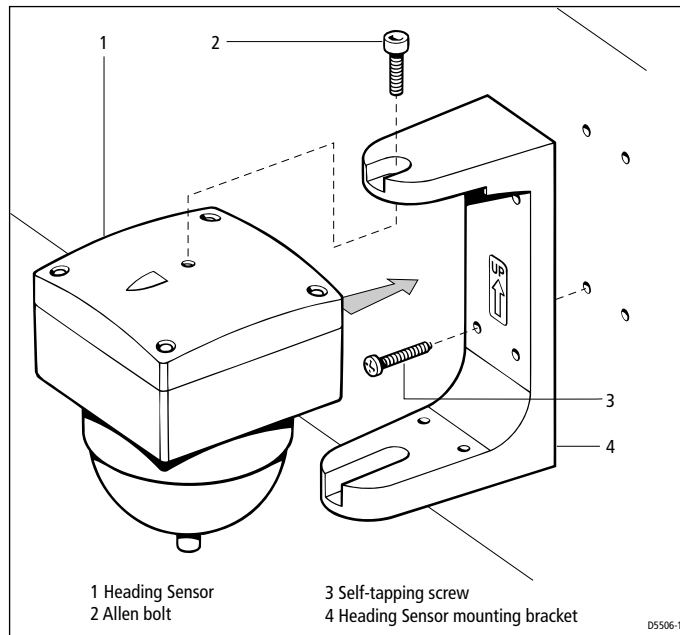

- Pass the Allen bolt (2) through the aperture in the top of the Heading Sensor mounting bracket (4) and tighten using the Allen key supplied.

Note: *You may need to loosen this later to adjust the Heading Sensor alignment, as described in Chapter 4, Calibration.*

3.4 Connection Procedure

To connect your Heading Sensor to an NMEA 0183 compatible instrument, such as a XX Radar:

- Plug the 6ft (2m) Heading Sensor cable (supplied) into the Heading Sensor.
- Connect the black and red wires from the cable to the corresponding wires from the NMEA 0183 compatible

equipment, using a suitable connector block, as shown in the diagram below. A 16.25ft (5m) NMEA accessory cable is available for more distant connection if required.

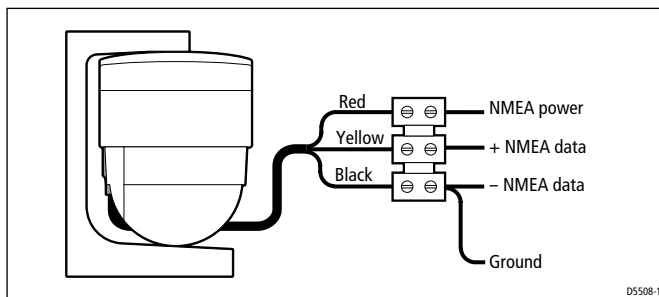

Check the handbook supplied with NMEA 0183 compatible equipment, to determine the correct pin connections for the heading sensor input. For example, the connections for a XX Radar are shown in the following diagram.

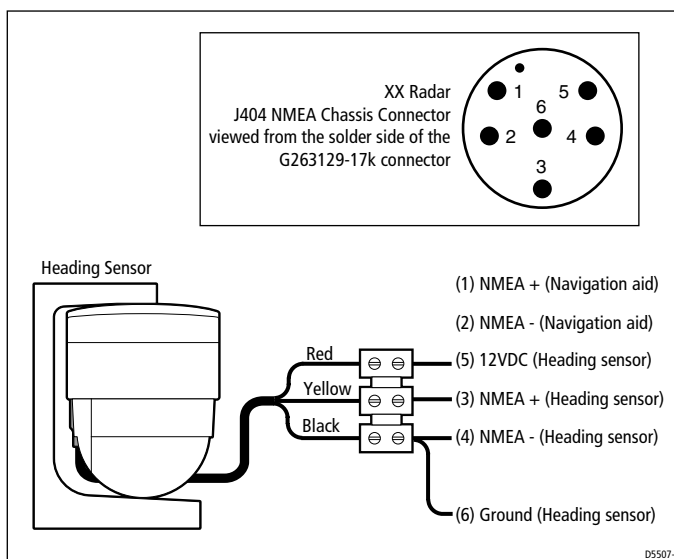

Chapter 4: Calibration

4.1 Introduction

The Raymarine Heading Sensor must be calibrated to ensure that the transmitted compass heading information is accurate. This procedure should be carried out before the unit is used as a navigational aid.

The calibration consists of two components:

- **Compass Linearisation:** This detects heading errors caused by iron objects, such as engines or gas bottles. Once such errors have been detected, the Heading Sensor corrects them automatically.
- **Heading Alignment:** This is required to match the displayed heading to a known heading or transit. You can align the Heading Sensor with your ship's compass, providing your ship's compass is accurate.

The compass linearisation is performed using the Raymarine Heading Sensor's Continuous Deviation Correction. The Heading Sensor monitors the deviation continuously and, if the required conditions are met, updates its correction data.

This chapter describes the Continuous Deviation Correction procedure and the heading alignment procedure.

EMC Conformance

- Always check the installation before going to sea to make sure that it is not affected by radio transmissions, engine starting etc.

4.2 Continuous Deviation Correction

The Raymarine Heading Sensor normally monitors magnetic deviation continuously. Every time your vessel completes a 360° turn within the time constraints of the system, the compass checks the new deviation data and updates its correction data if required.

Deviation data is only used if the vessel has completed a 360° turn in not less than three minutes, without any sudden increases in speed, and if this provides more accurate data than that already stored.

To ensure that the compass has received accurate data, perform the following procedure:

1. Choose a calm day, and select an area of open water. Ideally, the current and tide effects should be at a minimum.
2. Calculate the size of circle you need to make in order to keep your turn rate down to not less than 45 seconds for each 90° of turn.
You can turn more slowly than this, and you do not need to keep to an exact circle, but if you turn too quickly the deviation data will be ignored.
3. Turn your vessel continuously through two full circles (720°), at a slow, steady speed, keeping the vessel level. You can go either clockwise or anti-clockwise.
4. Ideally, continue to turn through a further two full circles to ensure you have obtained accurate data.

The Heading Sensor will now correct all heading readings using the variation data obtained.

4.3 Heading Alignment

After you have performed the Continuous Deviation Correction procedure, you should check the heading alignment. You can do so using one or both of the following techniques:

- Compare the heading information on your display instrument (such as a XX Radar or RayData) with the ship's magnetic compass for several headings.

Note: *Your magnetic compass must be accurate, and should have been calibrated recently.*

- Choose reference points from a chart, and navigate between them. Then compare the readings from your Heading Sensor with the actual chart courses.

If the Heading Sensor's readings differ from the actual readings by a constant amount, you need to correct the heading alignment. This is achieved by adjusting the position of the compass, as follows:

1. Loosen the Heading Sensor mounting slightly, so that you can rotate the sensor. To do this, use the Allen key supplied with the Heading Sensor to loosen the Allen bolt in the top of the Heading Sensor mounting bracket (see page 7).



2. If the Heading Sensor's readings are less than the actual readings, rotate the sensor slightly clockwise.
If the Heading Sensor's readings are greater than the actual readings, rotate the sensor slightly anti-clockwise.
3. Check the headings again, and repeat step 2 if required.
4. When the headings match, tighten the Allen bolt to hold the sensor in its new position.





Heading Sensor Specification

Dimensions:	90mm x 100mm x 130mm (3.5in x 3.9 in x 5.1in)
Power Supply:	10 to 16V DC
Power Consumption:	40mA
Operating Temperature:	-10°C to +70°C (14°F to 158°F)
Weight:	450g (1 lb)
Compatibility:	NMEA 0183 compatible equipment
Accuracy:	+/- 0.5°
Gimbal Range:	Pitch = +33°, Roll + 45°
Data Output (NMEA): (10Hz)	HDM (Magnetic Compass Heading) HDG (Heading only)



Limited Warranty Certificate

Raymarine warrants each new Light Marine/Dealer Distributor Product to be of good materials and workmanship, and will repair or exchange any parts proven to be defective in material and workmanship under normal use for a period of 2 years/24 months from date of sale to end user, except as provided below.

Defects will be corrected by Raymarine or an authorized Raymarine dealer. Raymarine will, except as provided below, accept labor cost for a period of 2 years/24 months from the date of sale to end user. During this period, except for certain products, travel costs (auto mileage and tolls) up to 100 round trip highway miles (160 kilometres) and travel time of 2 hours, will be assumed by Raymarine only on products where proof of installation or commission by authorized service agents, can be shown.

Warranty Limitations

Raymarine Warranty policy does not apply to equipment which has been subjected to accident, abuse or misuse, shipping damage, alterations, corrosion, incorrect and/or non-authorized service, or equipment on which the serial number has been altered, mutilated or removed.

Except where Raymarine or its authorized dealer has performed the installation, it assumes no responsibility for damage incurred during installation.

This Warranty does not cover routine system checkouts or alignment/calibration, unless required by replacement of part(s) in the area being aligned.

A suitable proof of purchase, showing date, place, and serial number must be made available to Raymarine or authorized service agent at the time of request for Warranty service.

Consumable items, (such as: Chart paper, lamps, fuses, batteries, styli, stylus/drive belts, radar mixer crystals/diodes, snap-in impeller carriers, impellers, impeller bearings, and impeller shaft) are specifically excluded from this Warranty.

Magnetrons, Cathode Ray Tubes (CRT), TFT Liquid Crystal Displays (LCD) and cold cathode fluorescent lamps (CCFL), hailer horns and transducers are warranted for 1 year/12 months from date of sale. These items must be returned to a Raymarine facility.

All costs associated with transducer replacement, other than the cost of the transducer itself, are specifically excluded from this Warranty.

Overtime premium labor portion of services outside of normal working hours is not covered by this Warranty.

Travel cost allowance on certain products with a suggested retail price below \$2500.00 is not authorized. When/or if repairs are necessary, these products must be forwarded to a Raymarine facility or an authorized dealer at owner's expense will be returned via surface carrier at no cost to the owner.

Travel costs other than auto mileage, tolls and two (2) hours travel time, are specifically excluded on all products. Travel costs which are excluded from the coverage of this Warranty include but are not limited to: taxi, launch fees, aircraft rental, subsistence, customs, shipping and communication charges etc. Travel costs, mileage and time, in excess to that allowed must have prior approval in writing.

TO THE EXTENT CONSISTENT WITH STATE AND FEDERAL LAW:

(1) THIS WARRANTY IS STRICTLY LIMITED TO THE TERMS INDICATED HEREIN, AND NO OTHER WARRANTIES OR REMEDIES SHALL BE BINDING ON RAYMARINE INCLUDING WITHOUT LIMITATION ANY WARRANTIES OF MERCHANTABILITY OR FITNESS FOR A PARTICULAR PURPOSE.

(2) Raymarine shall not be liable for any incidental, consequential or special (including punitive or multiple) damages.

All Raymarine products sold or provided hereunder are merely aids to navigation. It is the responsibility of the user to exercise discretion and proper navigational skill independent of any Raymarine equipment.

Raymarine

Factory Service Centers

United States of America

Raymarine Inc
22 Cotton Road, Unit D
Nashua, NH 03063-4219, USA

Telephone: +1 603 881 5200
Fax: +1 603 864 4756
www.raymarine.com

Sales & Order Services

Telephone: +1 800 539 5539 Ext. 2333 or
+1 603 881 5200 Ext. 2333

Technical Support

Telephone: +1 800 539 5539 Ext. 2444 or
+1 603 881 5200 Ext. 2444
Email: techsupport@raymarine.com

Product Repair Center

Telephone: +1 800 539 5539 Ext. 2118

UK, Europe, Middle East, Far East

Raymarine Ltd
Anchorage Park, Portsmouth
PO3 5TD, England

Telephone: +44 (0)23 9269 3611
Fax: +44 (0)23 9269 4642
www.raymarine.com

Customer Support

Telephone: +44 (0)23 9271 4713
Fax: +44 (0)23 9266 1228

Email: techsupport@raymarine.com

Stick barcode label here

Purchased from

Purchase date

Dealer address

Installed by

Installation date

Commissioned by

Commissioning date

Owner's name

Mailing address

This portion should be completed and retained by the owner.