

Distributed by
Raymarine

Any reference to Raytheon or RTN in this manual should be interpreted as Raymarine. The names Raytheon and RTN are owned by the Raytheon Company.



RayChart 620 and 630 Owner's Handbook

Document number: 81155_1
Date: XX Month 1999





RayChart 620 and 630 Electronic Charting Systems

Owner's Handbook

SAFETY NOTICES



1. HIGH VOLTAGE.

The display unit contains high voltages. Adjustments require specialised service procedures and tools only available to qualified service technicians – there are no user serviceable parts or adjustments. The operator should never remove the display unit cover or attempt to service the equipment.

2. NAVIGATION AID.

This device is only an aid to navigation. Its accuracy can be affected by many factors, including equipment failure or defects, environmental conditions and improper handling or use.

It is the user's responsibility to exercise common prudence and navigational judgement, and this device should not be relied upon as a substitute for such prudence and judgement.



RAYTHEON MARINE products are supported by a network of Authorized Service Representatives. For information on Raytheon products and services, contact either of the following:

UNITED STATES Raytheon Marine Company
676 Island Pond Road
Manchester, NH 03109-5420
Telephone: (603) 647-7530
800 539-5539
Fax: (603) 634-4756

EUROPE Raytheon Marine
Anchorage Park
Portsmouth
Hampshire PO3 5TD
England
Telephone: 01705 693611
Fax: 01705 694642

Copyright © Raytheon Marine Company 1998

The technical and graphical information contained in this handbook, to the best of our knowledge, was correct as it went to press. However, the Raytheon policy of continuous improvement and updating may change product specifications without prior notice. Therefore, unavoidable differences between the product and handbook may occur from time to time, for which liability cannot be accepted by Raytheon.

Raytheon is a registered trademark of Raytheon Company
SeaTalk is a registered trademark of Raytheon Marine Europe Limited
RayChart is a trademark of Raytheon Marine Company
C-MAP is a registered trademark.

Preface

This handbook covers the following electronic charting system from Raytheon Marine Company:

- RayChart 620 monochrome chartplotter
- RayChart 630 colour chartplotter

It contains very important information on the installation and operation of your new equipment. In order to obtain the best results in operation and performance, please read this handbook thoroughly.

Raytheon Product Support or your local dealer will be available to answer any questions you may have.

How this Handbook is Organized

This handbook is divided into the following chapters:

Chapter 1: Introduces the chartplotter's features and concepts.

Chapter 2: Explains how to start using the chartplotter, including instructions for turning it on, using the controls, changing the lighting, and using chart cards. This chapter also describes how to display navigational data. Simple exercises are included.

Chapter 3: Provides instructions for using the default soft keys to set up and use on-screen routes.

Chapter 4: Explains how to use additional basic functions, such as track histories, marks and events. It also explains how to use the MOB function.

Chapter 5: Provides information on the stored data, such as waypoints, routes and events, and how you can review, edit and use them.

Chapter 6: Provides instructions for customizing the chartplotter defaults, such as the numerical units used, the equipment connected and the alarm settings, to suit your preferences. It also explains how to customize the screen display.

Chapter 7: Provides instructions for installing the chartplotter.

Chapter 8: Provides information on maintenance, and what to do if you experience problems with your chartplotter.

Appendix A: Lists the system specifications.

A glossary, index and warranty information are included at the end of the handbook.



How to Use this Handbook

This handbook is organized with the information about operating the chartplotter at the front, since you will probably use these chapters most often.

When you first receive your chartplotter, you should read Chapter 7, and install the equipment. Then read Chapters 1 and 2 to familiarize yourself with the controls of the chartplotter. You may also wish to read Chapters 3, 4 and 5.

When you are happy with the basics of using the chartplotter, read Chapter 6, decide how you wish to set up your defaults, alarms and the screen, and follow the instructions to make your changes.

Once you are on the water, you can follow the instructions in Chapters 3 and 4 to perform all your routine tasks, and refer to Chapter 5 for information about more advanced features.

If you experience any difficulties with your chartplotter, refer to Chapter 8.

Note: The Quick Reference Card, included with your system, provides a useful summary of the chartplotter controls.

Warranty

To register your chartplotter ownership, please take a few minutes to fill out the warranty registration card found at the end of this handbook. It is very important that you complete the owner information and return the card to the factory in order to receive full warranty benefits.

EMC Conformance

All Raytheon equipment and accessories are designed to the best industry standards for use in the leisure marine environment.

Their design and manufacture conforms to the appropriate Electromagnetic Compatibility (EMC) standards, but correct installation configuration is essential to ensure that performance is not compromised.

Chapter 1: Introduction

1.1 Overview

The chartplotter is a sophisticated electronic charting system, which uses GPS, dGPS or Loran-C technology to make navigation as simple and accurate as possible.

The chartplotter displays chart information from the C-MAP NT® range of electronic chart cards (C-Cards), and position information from satellites or land-based radio beacons. It can also display virtually any data available from other compatible instruments in your system.

The chartplotter is designed to be extremely easy to use, while providing powerful options for handling data and customizing the system to match your requirements. Everyday functions are available at the touch of a button, with as much or as little help as you need. The on-screen prompt and menu system, from which you can select the functions and options you require, simplifies even complex tasks such as editing stored route data.

The monochrome display unit can be installed either above or below deck; the color display must be mounted below. The display can be illuminated for night-time use.

Features

- Chart display with zoom and pan control; a background world map is included, and there are two slots for inserting C-MAP NT C-Cards for large-scale cartography.
- Vessel's position displayed, with optional heading, course, tide and wind vectors, and optional track history display.
- Display options to control cartographic data displayed and windows for displaying navigational data, including Course Deviation Indicator (CDI) and Bearing Deviation Indicator (BDI), from other instruments.
- Plotter mode which allows the use of the chartplotter at ranges for which no chart information is available.
- 8 languages.
- Memory C-cards can be used to store and transfer route, waypoint, event and track history data.
- If two chartplotters are installed on the system, each can be operated independently, but the active route is displayed on both units.



Functions

- Quick and easy on-screen route setup and control.
- GOTO function navigating immediately to a waypoint.
- Event and mark recording.
- Edit and review functions for stored route, waypoint and event data.
- Setup options to customize the chartplotter according to your own system preferences, such as chart orientation (north up, course up or head up), display windows, and alarm setup.
- Ruler function for measuring chart distances.
- Centre options for centering the chart on the ship, cursor, or a specified position, and a Home Mode for displaying the vessels current position and tracking information.
- Alarm reporting and control, and a range of timers including countdown and elapsed timers.
- Log record.
- Print option.

Navigational Displays

The chartplotter is compatible with the SeaTalk® and NMEA 0183 standards. Full functionality of the chartplotter is achieved when it is part of an integrated system, with other equipment connected via Seataalk or NMEA 0183. Data from this equipment including position, waypoints and routes, is displayed on the chartplotter and is used in calculations. Details on connecting other equipment are given in *Chapter Seven*.

1.2 The Chart Display

The chartplotter includes a small-scale world map that can be used for route planning. Detailed navigation information is displayed when a chart card is installed.

Once the position fix has been established, the screen shows the chart area and associated data that were displayed when the chartplotter was last used.

The chartplotter screen includes a cursor data box which normally provides the following information:

- The cursor position, in either latitude and longitude or TDs, depending on your setup
- The vessel's Course Over Ground (COG) and Speed Over Ground (SOG)
- A mileage scale ruler in nautical miles
- The units in which depth data is displayed
- The cursor's bearing (BRG) and range (RNG) from your vessel's current position

The cursor data box is also used to display the vessel's position and the range and bearing to the active waypoint, when the chartplotter is in Home Mode (see *Section 3.2*).

An example chartplotter chart display, in its default configuration with a chart card installed, is shown in the top illustration overleaf.

The chart display can show additional information, depending on the current data and on your setup selections, as shown in the example chartplotter display in the bottom illustration opposite. You can also display the cursor position from other compatible displays (see *Chapter 6*).

Note: *If required, you can use the setup options to change the units in which information is displayed, turn off the cursor data box and soft key labels, and change the chart orientation (see Chapter 6).*



The Chart Display

Cursor data box
Shows the current cursor position as either Lat/Long or TDs

Scale rule,
in nautical miles

Chart boundary

Lat/Long grid

Vessel's heading vector

Vessel's current position

Cursor position,
controlled by the trackpad

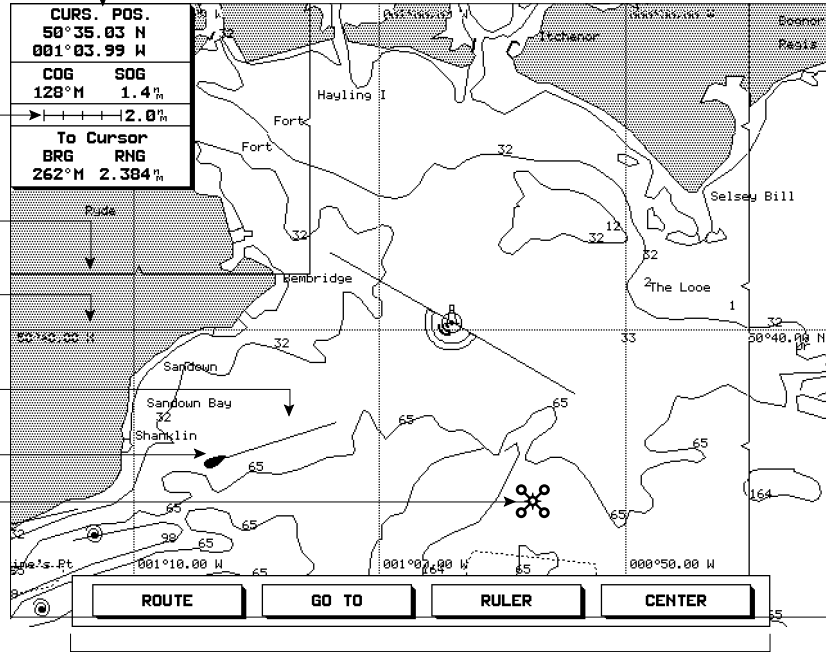

Default soft key labels

These can be turned off. To redisplay them, press any soft key.

Object data box

Route leg

Active waypoint

Track history

Mark Event

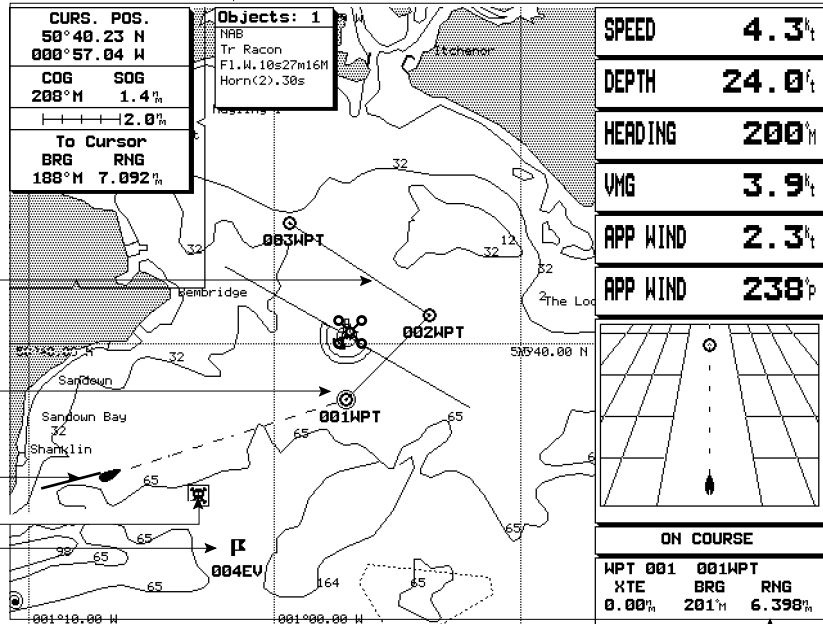

Customizable Window,
showing navigation data
and CDI

D3819-1

1.3 Operating Controls

You operate the chartplotter in a variety of ways; the control keys on the display unit are used with on-screen facilities such as pop-up menus. These include:

- A trackpad providing up, down, left, right and diagonal control of an on-screen cursor.
- Eight dedicated (labelled) keys.
- Four soft keys with labels displayed on the screen.
- Pop-up menus, displayed on-screen, from which you select options.
- Database lists, displayed on-screen, which enable you to edit items.

Note: *The cursor is the cross-hair symbol (⌘) visible on the display. You move the cursor with the trackpad and use it to select a position or item on the chart.*

The controls are shown on the following illustration. They are back-lit for night-time use. When you use a control, a help message is displayed at the top of the screen. You can switch help off as described in *Chapter 6*.

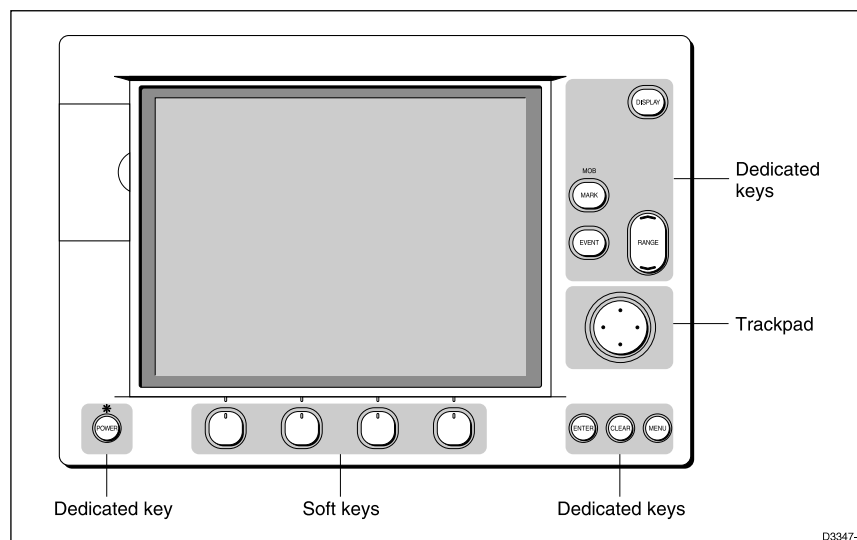

The Trackpad and Cursor

The trackpad and has several functions:

- To move the cursor around the chart screen
- To select an item from a pop-up menu or database list
- To adjust a variable soft key control
- To enter names in database lists

You can press on any of the four sections of the trackpad to move the cursor in that direction (up, down, left or right), or press two sections at the same time to

move diagonally. The cursor moves faster as you continue to press the trackpad. The current cursor position is shown in the cursor data box.

The cursor is displayed as a cross symbol (⌘) on the chart. It is used to:

- Select a position on the chart.
- Select an item e.g. waypoint, on the chart.
- Pan the chart display.

➤ *Try using the trackpad now to move the cursor around the chart. You can use short presses on the trackpad to move the cursor small distances, or press and hold to move the cursor quickly.*

As you move the cursor to the edge of the display, the display pans across the chart so that the area you have moved to remains in view. If you continue to scroll, the chart is redrawn on the screen at intervals.

If you move the cursor over an object for which there is information available, an Object Data Box appears at the top of the screen (see Chapter 2).

Dedicated Keys

These keys have fixed functions. Some keys can be used in two ways:

- **Press:** Press the key momentarily and then release it. This method is used for most key operations.
- **Press and hold:** Press the key and hold it down for the length of time stated (for example, 3 seconds), and then release it.

When you press a dedicated key, one of the following happens:

- a) The associated operation is actioned, e.g. change chart scale (**RANGE**).
- b) A pop-up menu is displayed, providing further options.
- c) A set of soft keys is displayed, providing further functions.

As you press a key, a single audio beep confirms the key action. If the key-press is not valid for the current screen or mode, three rapid beeps sound to indicate that no response is available. If required, you can turn the key beeps off as part of your set up procedure (see *Chapter 6*).

The dedicated keys are defined in the illustration on page 9.

The Soft Keys

The four keys below the screen are called soft keys because their functions change according to the operation. The soft keys are grouped into related sets and subsets providing access to the various functions. The soft key labels are displayed on the screen just above the keys. The default soft keys are displayed until you press a key, or select an item on the screen; the soft keys associated with the action are then displayed.

You can control whether or not the soft key labels are displayed all the time, using the system set up as described in *Chapter 6*. If no labels are displayed, press one of the soft keys to make them appear. The labels disappear again if you do not press a key for 7 seconds.

Similarly to the dedicated keys, when you press a soft key one of the following happens:

- a) The associated operation is actioned, e.g. GOTO.
- b) A sub-set of soft keys is displayed, providing further functions.
- c) A pop-up menu is displayed, providing further options.
- d) The appropriate database list (route, waypoint or track) is displayed.

As with dedicated keys, when you press a key, a single audio beep confirms the key action. If the key-press is not valid for the current screen or mode, three rapid beeps sound to indicate that no response is available. If required, you can turn the key beeps off as part of your set up procedure (see *Chapter 6*).

Soft Key Default Functions

In **default mode**, the soft keys provide a quick method of performing the tasks you will probably use most often, and which are described in detail in Chapter 3.



D3352-2

You use the soft keys to access the following functions:

ROUTE	Set up or edit an on-screen route of waypoints, and navigate towards them in turn
GO TO	Navigate towards a location you have indicated with the cursor
RULER	Measure distances and bearings on the chart
CENTER	Center the chart on the cursor, vessel or a specified position, or select Home Mode

If different soft keys are displayed, press the **CLEAR** key to select the default functions.

► Try using the **CENTER** key to center the chart on the cursor position:

1. Move the cursor to one side of the chart.
2. Press the **CENTER** soft key.

New soft key labels appear above the keys.



3. Press the **CENTER CURSOR** soft key.

The cursor and its current chart location both move to the center of the screen.

4. Press **CLEAR** to leave the option and return to the default screen, with the new chart position.

Other Soft Key Functions

In addition to the default softkeys, the dedicated keys **MENU**, **EVENT**, **MARK**, **DISPLAY** or **POWER** provide access to different functions; these functions have associated soft keys as shown in the illustration on page 9.

Press **CLEAR** to return to the default display.

Pop-Up Menus

Pop-up menus usually provide set up options. You use the trackpad to select an option from the menu, then use the appropriate dedicated key to set the option. An on-screen prompt tells you which dedicated key to use.

Database Lists

The waypoints, routes and tracks that you create on the chartplotter are stored in database lists. You can view these lists and select items for editing.

When a database list is on-screen, a set of associated soft keys is also displayed; you use the trackpad to select an item from the list, then use the appropriate soft key to edit the item. For example, you can delete a waypoint or a route.

Chapter 2: Getting Started and Controlling the Chart Display

2.1 Introduction

This chapter provides information, instructions and simple exercises to get you started using the chartplotter. It will help you to become familiar with the chart display and the functions of the controls before you start using the chartplotter for routine navigation. It also explains how to change the lighting, how to use chart cards and how to control the chart display.

More detailed information on operating the chartplotter is given in Chapters 3, 4 and 5.

Text Conventions

Throughout this handbook, the dedicated (labelled) keys are shown in bold capitals; for example, **MENU**. The soft (unlabelled) key functions, menus and options are shown in normal capitals; for example, ROUTE.

Operating procedures, which may consist of a single key-press or a sequence of numbered steps, are indicated by the ► symbol in the margin.

The short exercises in this chapter are shown in italic type, like this paragraph.

Terms included in the glossary are shown in **bold** type.

2.2 Turning the Chartplotter On and Off

► To turn the chartplotter on and start operation:

1. Press and release the red **POWER** key.

The keys light up, and the display shows the last-used chart. Over this is the chartplotter status screen, which includes:

- Software version number
- Database version number
- Card number and description for each of the two card slots, if in use. After 10 seconds, the following caution is displayed:

CAUTION

The charts displayed on your Chartplotter are based on geographical data that C-MAP Believes to be accurate. However you should not rely on these displays as your primary source of navigation, rather your Chartplotter should be used only as a backup to official government charts and traditional methods of navigation.

Note: You can now turn on and adjust the display backlighting and contrast, if required, as described later in Section 2.3.

- When you have read the notice, press the CONTINUE soft key to clear the caution.

The Fix Status window, providing GPS status information as shown in the following example, is displayed.

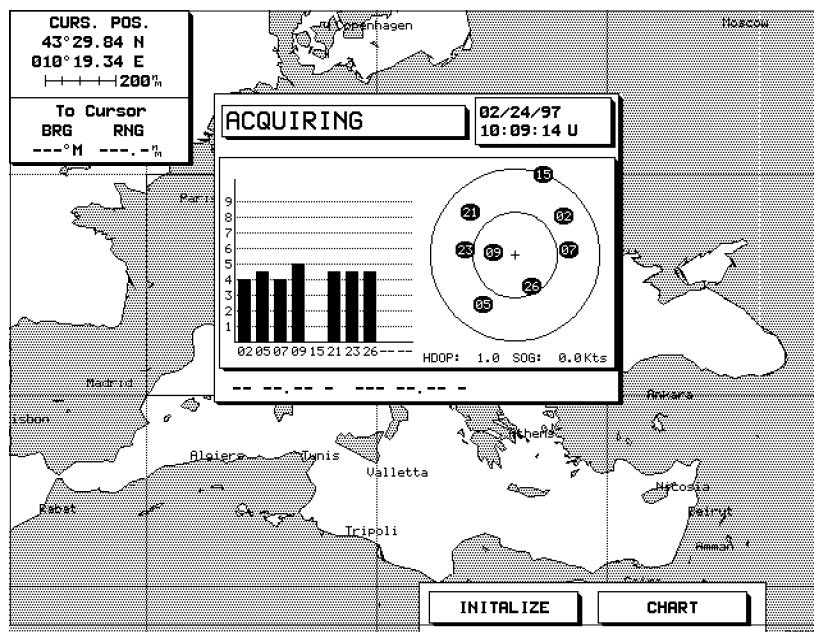

The right side of the window shows a representation of the satellite positions, with each satellite identified by a number. The bargraphs on the left indicate the signal strength for each of the currently located satellites. Initially, the chartplotter uses the predicted satellite positions, and the bargraphs are blank until the satellites are located.

The GPS searches for the strongest signals: at least four are required for an accurate position fix. If the signals from the currently located satellites are not strong enough, the GPS searches for other satellites and these are displayed in turn.

- To clear the Fix Status window and display the chart, press the CHART soft key. (You can redisplay the Fix Status window later if required, as described in Chapter 6.)

If a position fix has not been established, a “Fix Alarm” message is displayed. You can clear the alarm by pressing any key. The unit will beep every few seconds to indicate there is no position fix, until the position has been established.

The soft keys INITIALIZE and BEACON can be used to initialize the GPS and to manually set up a differential beacon. These functions are described in Chapter 6.

- To turn the chartplotter off, press and hold the **POWER** key for three seconds. A countdown timer is displayed, and if you release the key before the timer reaches zero the chartplotter will remain on. Otherwise, when the timer reaches zero the chartplotter display is cleared and the key lights go off.

2.3 Adjusting the Lighting and Contrast

You can change the level of screen backlighting and monochrome screen contrast.

- A 620 Chartplotter with a monochrome display has six brightness levels and 40 contrast levels.
- A 630 Chartplotter with colour display has six brightness levels and a day/night view setting.

Note: *The colour display lighting can be dimmed but cannot be turned off.*

The control key lighting is bright when the screen backlighting is on. When the screen lighting is off, the keys are lit at a low level so you can always find the keys.

- To change the backlighting and contrast:

1. Press the **POWER** key. (Do not press and hold the key, or the power-off message will be displayed.)

Two sliders appear on the monochrome screen, showing the current settings for brightness and contrast; the soft keys provide control of the sliders.

The brightness slider is displayed on the colour screen; the soft keys provide control of the slider and the night /day setting.

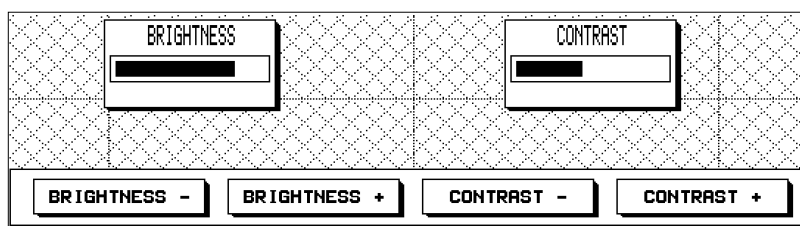

2. Press the appropriate soft key, to adjust the backlight brightness or the contrast to the required level. The brightness and contrast change as you adjust the sliders.

On the colour display, press the NIGHT VIEW/DAY VIEW soft key to toggle between the night and day setting.

3. Press **ENTER** to store the new settings and return to the standard display with default soft keys.

Alternatively, after several the seconds the lighting controls are removed and the screen returns to the standard display.



The new lighting and contrast levels are retained until you reset them or turn off the chartplotter.

At power-on, the monochrome screen lighting is always off, but the last-used contrast setting is retained.

The colour screen powers-on at the last used settings for brightness and night/day view.

2.4 Using Chart Cards

The chartplotter has a built-in world map that can be used for route planning. Most areas are covered on a scale of about 500nm per inch on the screen (200nm per cm), although some populated areas have details down to 300nm per inch on the screen. The chartplotter displays a scale indicator on the screen for all chart displays.

To use the chartplotter as a navigation aid, charts with detailed information for the area you wish to navigate are required. These are available on C-MAP NT electronic chart cards (C-Cards), each of which can store as many as 20 charts in an electronic format. A single C-MAP chart normally provides as much information as is available in paper charts for that geographic area, with detail up to 0.05nm per inch.

The chartplotter allows you to install two chart cards at the same time. You can also use the slots for C-MAP Memory C-Cards, which allow you to store and retrieve data such as waypoints and routes.

Note: You can insert and remove cards while a chart is displayed. The chart information is retained until the chartplotter redraws the screen: for example, when you pan outside the current area, or use the **RANGE** key to change the chart scale.

Inserting a Chart Card

- To insert a chart card:
 1. Check that the card is the correct format (C-MAP NT C-Card), with the required chart stored on it.
 2. Open the card cover, at the top left of the chartplotter front panel, by pushing the latch to the left and then opening the cover as shown in the illustration on the following page.
 3. Hold the card with the printed text pointing towards the right and the correct way up, as shown in the illustration.
 4. Gently push the card into one of the two sockets. It will only go in if it is the right way round.

Push the card in as far as it will go, then move it to the left so that the top is under the retaining pegs. Release the card so that it is held in place by the pegs.

5. Close the card cover so that it clicks shut, to stop water splashing into the chartplotter.

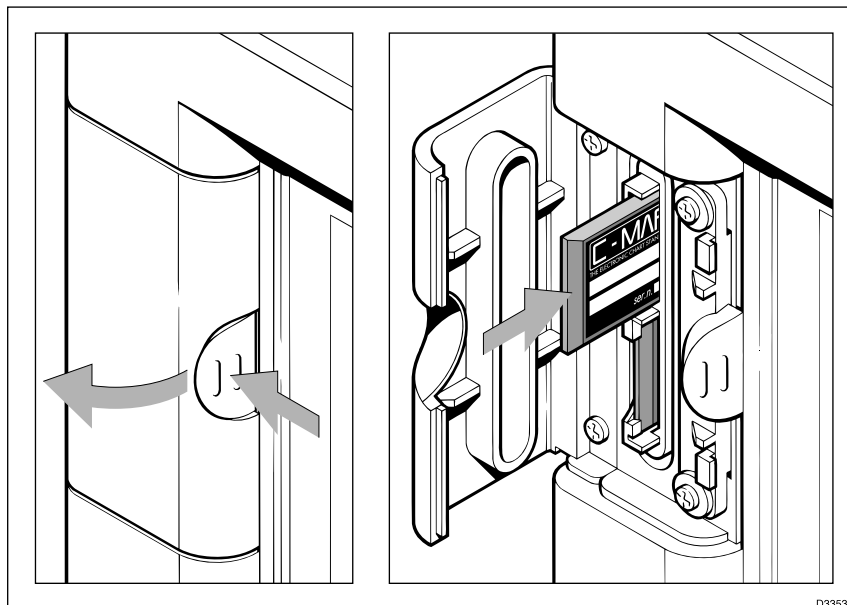

Using
Chart Cards

Removing a Chart Card

- To remove a chart card:
 1. Open the card cover, at the top left of the chartplotter front panel, by pushing the latch to the left (see above).
 2. Press down the card you wish to remove, and move the top of the card to the right to clear the retaining pegs.
 3. Pull out the card.

Displaying the Chart Data

The new chart information will be displayed when you move the cursor into an area covered by the new chart or, if it is already in the area, change the range scale.

The boundary of each chart digitized in the current card is shown as a box or rectangle. (You can switch off the chart boundaries display if you wish, as part of the chartplotter setup described in *Chapter 6*.)

- To zoom in:
 1. Use the trackpad to move the cursor inside one of the chart boxes, and press the lower part of the **RANGE** key.

That area is expanded so that you can see more detail. Note that the smaller the chart box is on the screen, the greater the amount of detail that is available when you zoom in.

Unless you have turned on the **Plotter Mode**, you cannot zoom in further than the most detailed chart, and you cannot zoom out further than the world map.

Displaying Information About Objects

Chart cards include a number of displayed objects for which information is available, such as lights and buoys. Chart source data is also available and, if your chart includes port and tide data, this can be displayed. You can use the cursor to identify the object and display detailed information. In addition, position information is available for waypoints and events added using the chartplotter functions.

- To obtain the chart object information:

1. Move the cursor over the symbol for which you require the information. After a moment, an Object data box appears at the top of the screen, as shown at the top of the example below.

If the cursor is over more than one object for which information is available, the number of objects is shown and their descriptions are listed.

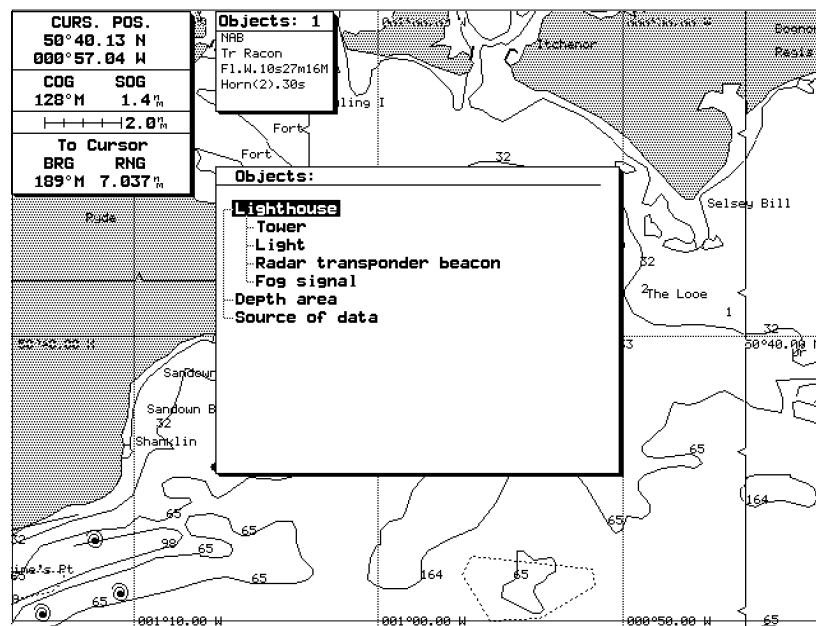











































2. To view further details, press **ENTER**. The soft keys EXPAND, ALLINFO and NEAREST are displayed.
3. To obtain expanded information about the object(s):
 - a. Press the EXPAND soft key. The objects and any sub-objects are listed in a window in the center of the screen.
 - b. Use the trackpad to scroll up and down the list, and highlight the required object or sub-object.
 - c. Press **ENTER**. Any available information is displayed. If there is more than one page of information for the object, you can page through it using the PAGE DN soft key, and go back to the beginning using the RESTART soft key.
 - d. Press **CLEAR** to return to the expanded list, and select another object if required.
 - e. Press **CLEAR** to clear the expanded information display, and return to the EXPAND and ALLINFO soft key display.
4. To obtain all the information available at this location:
 - a. Press the ALLINFO soft key. The information is displayed in the same way as the expanded data, but includes additional information such as the depth range and the source of the data.
 - b. Press **CLEAR** to clear the detailed information display, and return to the EXPAND and ALLINFO soft key display.
5. To obtain port information for the nearest ports:
 - a. Press the NEAREST soft key. The port facility symbols are displayed.
 - b. Use the trackpad to highlight the facility for which you require information, then press **ENTER**.
 - c. The nearest ports providing that facility are listed, with distance and bearing to the port. If you highlight a port name, then press **ENTER** the cursor moves to that port (redrawing the chart) and the details for that facility are displayed.
 - d. Press **CLEAR**, the facility symbols for the selected port are displayed as described below.
6. Press **CLEAR** to return to the default display.

Port Area

At large chart scales **port area** information is indicated by the symbol .

Where available, details for each facility can be displayed. In some areas the chart shows symbols for individual facilities. The facilities and their associated symbols are defined below.

- To obtain port facility details
 1. Place the cursor over the port symbol . The port facility symbols are displayed
 2. Press **ENTER** to display the soft keys EXPAND, ALL INFO and NEAREST.
 3. Press EXPAND or ALL INFO to list the port facilities in the object information pop-up.
 4. Use the trackpad to highlight the required facility then press **ENTER**. The details for that facility are displayed.
 5. Press **CLEAR** three times to return to the default display.

		GAS					
Bank-Echange Office	Accessories	Bottle Gas	Boat Hoist	Parking	Boat Yard	Chandler	Commercial Fishing
							
Camping Site	Coast Guard	Crane	Car Parking	Customs	Caravan Site	Scuba	Electricity
							
Elect. Repairs	Health Emergency	Engine Repairs	Fuel Station	Telegraph	Hotel-Inn	Harbour Master	Laundrette
							
Pharmacy	Police	Port Marina	Provisions	Post Box	Post Office	Radio	Marine Repairs
							
Restaurant	Refuse Bin	Radio Telegraph	Sailmaker	Sewerage station	Showers	Slipway	Public Telephone
				+	YC		
Public Toilets	Transportation Services	Visitor's Berth	Water	Waypoint	Yacht Club		



2.5 Controlling the Chart

You control the chart display using the cursor and control keys. You start all operations with the default soft keys displayed (this is referred to as the default screen in the following sections).

When you have completed an action using the soft keys sub-sets, to return to the default screen, press **CLEAR**; you may need to press **CLEAR** several times to back-track through the sub-set hierarchy.

Note: If you have set up your system so that the default soft keys are not displayed all the time, press any soft key to display the labels.

Although you can use your chartplotter with the whole screen devoted to the chart, you can also display navigation data in one or two **windows**, with the chart displayed in the rest of the screen. Navigation data windows are controlled using the **DISPLAY** key.

This section describes how to:

- Move around the chart by panning the display, changing the chart scale and changing the chart centre.
- Display navigation data.

Note: *The orientation of your chart (North Up, Course Up or Head Up) depends on your choice when you set up the chartplotter, as described in Chapter 6.*

The chart controls are summarised in the illustration on the page 9.

Moving the Chart

You will normally operate the chartplotter with the chart showing your vessel's current location. In the default North-Up orientation, the display is in **True Motion** mode, in which the vessel moves across the screen. You will need to move the chart if your vessel moves out of the area currently displayed, or if you wish to examine or place marks/waypoints in another area.

There are three ways in which you can move the chart:

- Use the **trackpad** to move the cursor to the edge of the chart. The chart will pan across (see *Section 1.3*). This method is useful if the area you wish to see is only just off the screen.
- Use the **RANGE** key to zoom out to a small scale chart, move the cursor to the centre of the required area, then zoom in on the new area. This method is useful if the area you wish to see is a long way away.
- Use the **CENTER** soft key to center the chart on one of a choice of positions: the vessel's position, the cursor position or a specified position.
- Automatically re-center the chart using the **HOME** option.

Note: If you have selected a chart display with one or two data windows, the chartplotter will treat the start of the data window as the edge of the chart.

Changing the Chart Scale

The **RANGE** key allows you to change the cartography scale so that you can see a smaller or larger area on the screen. Plotter mode is available to allow you to zoom into a smaller area, even when no chart data is available for that scale. *Chapter 6* describes how to set plotter mode on/off.

You can change the chart scale for two purposes:

- To see either more detail (a smaller area) or a larger area on the screen
- To move the display to another area of the chart, by zooming out to a small scale chart, then zooming in on another area

Small scale charts give you the wider view, but without the level of detail that you may need in order to navigate safely. The amount of detail that is visible depends on the amount available for that chart, and also on how you have specified the cartographic detail when you set up your chartplotter (see *Chapter 6*).

➤ To zoom in to a larger scale chart:

1. Use the trackpad to position the cursor in the area you wish to see in more detail.
2. Press the lower part of the **RANGE** key.

The section of the chart around the cursor is enlarged to fill the screen with a larger-scale chart showing more detail. The cursor is now positioned in the center of the screen.

The range scale indicated at the top left of the screen is updated.

Note: If you hold down the **RANGE** key, the range scale display is updated quickly without the chart being redrawn. Simply release the key when the required scale is shown, and the chart will then be updated.

3. If further chart enlargement is available using the current chart card you can press the bottom of the **RANGE** key to zoom in again, repositioning the cursor first if required.

An area of further chart detail is indicated by a box around the area.

4. When no further chart detail is available, as you press the bottom of the **RANGE** key, the effect depends on whether you have set **Plotter Mode** on or off as follows:
 - If Plotter Mode is *off* (the default setting), the chartplotter beeps three times and the range scale remains unchanged.
 - If Plotter Mode is *on*, the range scale is increased and the display shows grid lines and no cartography. The letter “P” is displayed after the scale rule

to indicate that the chartplotter is in Plotter Mode.

The cartographic information is restored when you return to a chart scale for which the information is available.

- To zoom out to a smaller scale chart, simply press the upper part of the **RANGE** key as many times as required. If no smaller scale chart is available, then the chartplotter beeps three times when you press the upper part of the **RANGE** key.

Changing the Chart Center

You can move a chosen point to the center of the chart, using the **CENTER** soft key. The chosen point can be the vessel's position, the cursor position or a specified position.

You can also select **Home Mode**, which centers the vessel, homes the cursor and changes the cursor data box to provide information about your vessel's position.

Note: Changing the range scale always centers the chart on the cursor.

Centering the Chart

- To center the chart using the **CENTER** options:
 1. From the default soft key display, press the **CENTER** soft key.

The following soft keys are displayed:



D3351-1

2. Press the soft key for the center option you require (or **CLEAR** to return to the default screen without change):
 - **CENTER SHIP** moves the chart so that your vessel's position is at the centre of the chart, and repositions the cursor so that it is over the vessel
 - **CENTER CURSOR** moves the chart so that the point you selected with the cursor is at the centre of the chart
 - **REMOTE CENTER** provides a box for you to enter the position for the new center
 - **HOME** moves the chart so that your vessel's position is at the centre of the chart, and enters Home Mode (see below)
3. If you pressed **REMOTE CENTER**, the box displays the current cursor position, as latitude and longitude or TDs depending on your system.

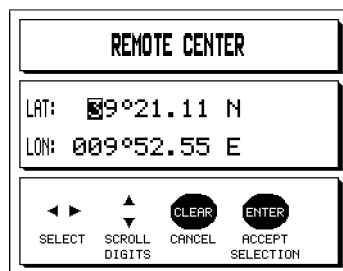

D3821-1

Change the values to the required position, as follows:

- a. Move the cursor to the first digit you wish to change, using the left or right trackpad controls. When you move right from the latitude direction, the cursor moves to the first longitude digit.
 - b. Increase or decrease the number, using the up or down trackpad controls.
 - c. Repeat steps a and b until all the digits are set to the required values.
 - d. Press **ENTER** to set the position.
4. The display returns to the CENTER soft keys display, with the new chart position. Press **CLEAR** to return to the default display.

Using Home Mode

When you select the HOME option, the chartplotter centres the vessel and changes to Home Mode. In this mode:

- The cursor is not displayed, and is fixed to the vessel's position
 - The cursor data box displays the vessel's current position; if you are tracking to a waypoint, it also displays the waypoint name, bearing and range
 - In Head Up or Course Up modes (see *Chapter 6*), the display changes to **Relative Motion**, in which the chart moves to keep the vessel in the centre of the display.
- To return to the standard cursor and motion mode, press the trackpad. The cursor re-appears and the cursor data box displays the cursor position data.

Displaying Navigation Information

Although you can use your chartplotter with the whole screen devoted to the chart, you also have the option of displaying a wide range of navigational data.

This information is normally presented in one or two **windows**, with the chart displayed in the rest of the screen. Three options are available for displaying navigational data:

- Chart displayed Full Screen, with no additional data.
- Chart displayed with pre-defined navigational data in one or two Windows.
- Chart with Navigation insert displaying Bearing Deviation Indicator (BDI) or Coarse Deviation Indicator (CDI).

The navigational data windows are controlled using the **DISPLAY** key. When you press the **DISPLAY** key, the following prompt is displayed, with the last-used option highlighted:

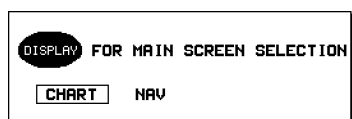

D3839-1

Press **DISPLAY** to toggle between the two settings:

CHART Displays the last used option used last – Full Screen chart, or chart with window.

The soft keys let you toselect a FULL screen chart,or a chart with the current WINDOW(s) configuration. If Windows are selected, you can change the window configuration.

NAV Displays the chart and inserts the last-used navigation indicator at the bottom right of the screen. You can use the soft keys to select a BDI or CDI display.

The soft key labels disappear after 7 seconds if you do not make a selection.

The display options are described in more detail in the following sections.

Chart

The Chart soft keys let you select either a Full Screen chart or a chart with data window(s). When you press the **DISPLAY** key to select the **CHART** option, the last used configuration is displayed.

Ten navigational data windows are available for display; six are pre-defined and supplied with the chartplotter, in addition four can be customized as part of your set up procedure, described in *Section 6.3*. You can display one or two data windows and select the window position.

The windows soft keys disappear after seven seconds if you do not make a selection.

If you wish to change the display again, press **DISPLAY**. The soft keys are re-displayed.

Changing between Full Screen and Windows

- You can change between the full screen display and windows display using the soft keys as follows:

FULL Clears any data windows .

WINDOW Displays the chart with navigational data, in the current default windows configuration.

Press **CLEAR** to return to the default soft key display (if selected in your setup selection, see *Chapter 6*).

Changing the Window Setup

The **WINDOW SET UP** soft key lets you change the window configuration.

You can select:

- The number of windows (1 or 2)
- The position of the windows on the screen
- The contents of the windows, by selecting from the list of predefined or customized windows available

Note: If the help level is set to Level 1 (the factory setting), the windows are moved up the screen so that they do not overlap the default soft keys. This means that you cannot select two windows in a full-height column: if you wish to do so, you must change the help setting to Level 0, as described in *Chapter 6*.

- To change the default window configuration:
 1. Press **DISPLAY** to display the Chart soft keys (see above).
 2. If a window is not already displayed, press the **WINDOW** soft key.
 3. Press the **WINDOW SET UP** soft key to display the selection keys and current settings, as shown in the following example.

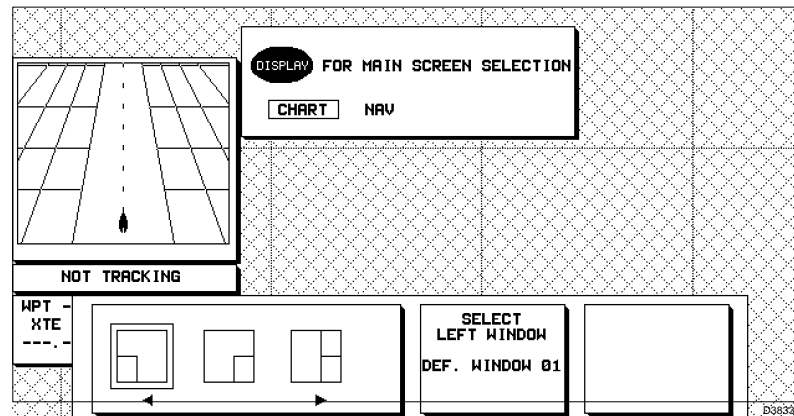

4. Use the two left-hand soft keys to select the number and location of the windows. You can select:
 - One window at the bottom left of the chart display
 - One window at the bottom right of the chart display
 - Two windows, one above the other, in a full-height column at the right of the chart display

The display changes as you highlight the different settings.

5. Use the **SELECT LEFT WINDOW** or **SELECT RIGHT WINDOW** soft key to scroll through the available data sets for the window.

Each time you press **SELECT WINDOW**, the next available set of data is displayed in the current window. These sets include the six default windows supplied with your chartplotter, plus the four custom windows you can set up as part of your display setup procedure (see *Chapter 6*).
6. When you are happy with your selections, press **ENTER** to return to the Display Selection screen.

Alternatively, press **CLEAR** to cancel your selections and retain the previous default configuration.
7. Press **ENTER**, or wait 7 seconds, to return to the defaults display.

Navigation

The NAVigation display soft keys let you to select a chart display with either of the following:

- **CDI**, the Course Deviation Indicator, which shows off-course error as the distance your vessel is from the current track
- **BDI**, the Bearing Deviation Indicator, which shows off-course error as the difference between your vessel's heading and the bearing to waypoint

When you press the **DISPLAY** key to select the NAV option, the indicator you

last used (CDI or BDI) is shown.

The soft keys disappear after 7 seconds if you do not make a selection.

The CDI or BDI data is presented in a window at the bottom right of the screen, with steering data, as shown in the examples below:

CDI (Course Deviation Indicator)

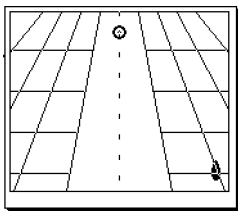

Waypoint graphic, fixed until within 3nm then moves down the screen

Rolling range lines at 1nm intervals

Vessel graphic

On-course indicator or direction to steer indicator
 First arrow - XTE more than 0.01nm
 Second arrow - XTE more than 0.05 nm

Waypoint sequence number and name, with cross track error, bearing and range to waypoint

HPT	001	001	HPT
XTE	BRG	RNG	
0.11%	200°	5.940%	

BDI (Bearing Deviation Indicator)

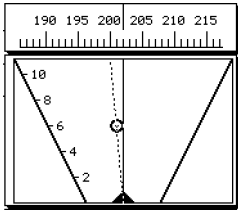

Compass

Range, updated as the vessel moves

Waypoint graphic, moves as distance and bearing to waypoint change

On-course indicator or direction to steer indicator

Waypoint sequence number and name

Cross track error, and bearing and range to waypoint

HPT	001	001	HPT
XTE	BRG	RNG	
0.11%	200°	5.940%	

D3834-1

Controlling the Chart

If there is no active waypoint, the message “NOT TRACKING TO WAYPOINT” is displayed in the window.



Chapter 3: Using the Default Soft Keys

3.1 Introduction

This chapter explains how to perform some basic chart operations using the trackpad, and the default soft keys. The default soft key display is shown below.

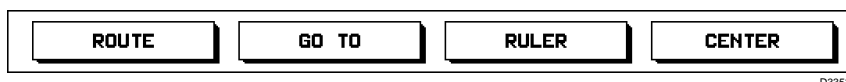

Note: If you have set up your system so that the soft keys are not displayed all the time (Help Level 0), press any soft key to display the labels.

This chapter covers the following topics:

- Using the GO TO key to navigate towards a selected point
- Setting up and using on-screen routes
- Measuring distances using the RULER key

Further basic functions, including track histories and placing marks and events, are described in Chapter 4. More advanced operation, involving the stored lists, is described in Chapter 5, including retrieving stored routes and making new routes using stored waypoints.

Safety

The chartplotter makes it very easy to mark a waypoint and track towards it. However, you should always check first that the route is safe. If you are using the chartplotter in combination with a SeaTalk autopilot, the autopilot will prompt for confirmation before it steers the vessel towards the waypoint.

If you have entered your route using a small-scale chart, zoom in to a larger scale to check for hazards, such as small shoals, that may not be shown on the smaller scale.

3.2 Using the GO TO Key

The GO TO default soft key provides a quick method of navigating to a target point. You can select any target point (which is then stored as a new waypoint) or an existing waypoint.

Note: You can also search for a specific waypoint and track towards it using the Waypoint List options (see Chapter 5).

Tracking to a Target Point

► To navigate to a target point:

1. Use the trackpad to position the cursor on the target point.
2. Press GO TO.

Unless you are already tracking to a waypoint (see below), the chartplotter saves the target point as a new **waypoint** and starts tracking towards it. If your target point is an existing waypoint, its position is used and a new waypoint is not created.

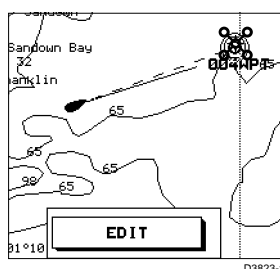

The waypoint is shown as a circle with a dot in the center, and is connected to the vessel's starting position with a dashed line. The waypoint is given a default name of the format *xxxWPT*, where *xxx* is the next available waypoint number.

3. Press the EDIT soft key, that is displayed for 7 seconds, if you wish to change any of the waypoint information for the new waypoint:

Editing the Waypoint Details

You can change the new waypoint's name, symbol and position.

► To edit the waypoint details:

1. Press the EDIT soft key that is displayed for 7 seconds after you request the GO TO. A window such as the following is displayed:

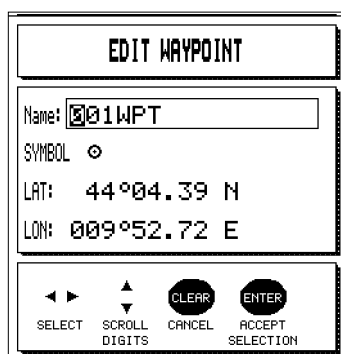

D3825-1

2. Use the left or right sides of the trackpad to move the cursor to the number, letter or symbol you wish to change. You can hold the trackpad down to move quickly.
3. Use the top or bottom of the trackpad to increase or decrease the number, or change the letter or symbol.
4. Repeat steps 2 and 3 until the required information is displayed.
5. Press **ENTER** to save the details.

Using the
GO TO Key

Clearing or Changing a GO TO

If you are already navigating to a waypoint when you request a GO TO, the chartplotter displays the following message:

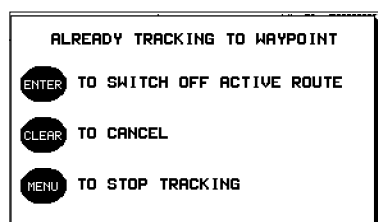

D3824-1

The active waypoint may be a previous GO TO, or it may be the current waypoint in an active route.

- To change to the new waypoint (GO TO target point), press **ENTER**.
- To cancel the GO TO and continue navigating to the existing waypoint, press **CLEAR**.
- To stop navigating to the active waypoint, press **MENU**.

Note: This means you can abandon a GO TO at any time by pressing GO TO then **MENU**. If you turned off the waypoint display when you set up your chartplotter, the waypoint disappears since only the active waypoint and the current route waypoints are displayed (see Chapter 6).

3.3 Setting Up and Using On-Screen Routes

The ROUTE soft key provides a quick and easy method of setting up (or selecting) and using a route.

Note: You can also create, edit and control routes using the EDIT menu options, as described in Chapter 5.

The chartplotter can store up to 20 routes. When you want to create a new route, you can either select an empty route slot, or select an existing route and edit or erase the old route data. If you need to keep more than 20 routes, you can save the information to a memory card (see Chapter 6).

Note: If you have two chartplotters on your system, the current route (active or selected) or GO TO on one chartplotter is displayed as Route 0 on the other chartplotter. It is therefore advisable to avoid using Route 0 when you create a route.

When you press the ROUTE soft key, a menu such as the following is displayed:

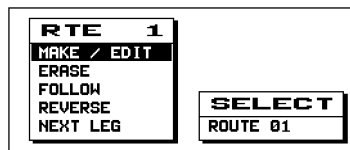

Note: The route number selection defaults to the last-used route. If this route is empty, only the Make / Edit menu option is displayed. For Route 0, if the route is the active route from another chartplotter, the ERASE and REVERSE options are not displayed.

The menu options are as follows:

- | | |
|-------------|---|
| MAKE / EDIT | Used to set up a new route using the cursor. You can also use this option to edit an existing route, adding and removing waypoints, and to edit route information such as waypoint names and symbols. |
| ERASE | Used to clear the existing route from memory. This deletes the route, but not its component waypoints. |
| FOLLOW | Used to start tracking to the first waypoint on the route. |
| or OFF | Used to stop tracking. This soft key is displayed instead of FOLLOW when a route is already active. |
| REVERSE | Used to reverse the tracking order of the waypoints in the route. |
| NEXT LEG | Used to proceed to the next leg of the route. |

Making a New On-Screen Route

- To making a new route using the ROUTE soft key :
 1. Move the cursor to the area in which you wish to make the route, and select a suitable chart scale.
 2. Press the ROUTE soft key to display the Route menu and the current route.

Note: *If the full list of ROUTE options is displayed, a route already exists in the selected route slot. You can select ERASE to delete the route (see page 30), or continue with this procedure to add waypoints to the existing route, as described below.*
 3. If required, press the SELECT soft key to select an empty route slot.
 4. Press **ENTER** to select the highlighted Make/Edit option.

The soft key labels change, as shown in the illustration below.
 5. Use the trackpad to move the cursor to the position on the chart where you want your first waypoint to be.

Note: You can position the cursor on an existing waypoint, if required. This waypoint will be included in the route, and a new waypoint will not be created.
 6. Press the PLACE WPT soft key.

The waypoint appears on the screen at the current cursor position, together with the waypoint number assigned by the chartplotter.

The first waypoint of a new route has a circle round the waypoint symbol, indicating that it will be the active waypoint if the route is made active.

The cursor data box and object data box are updated to show the waypoint number and position, as shown in the example below.
 7. Move the cursor to the next waypoint position. A dotted line connects the cursor to the previous waypoint.
 8. Press PLACE WPT again. The waypoint is placed and the dotted line changes to a solid line.

Note: *If you make a mistake, you can delete a wrongly-placed waypoint or insert an additional one, as described below.*
 9. Repeat steps 7 and 8 until you have placed all your waypoints. You can have up to 50 waypoints in a route.

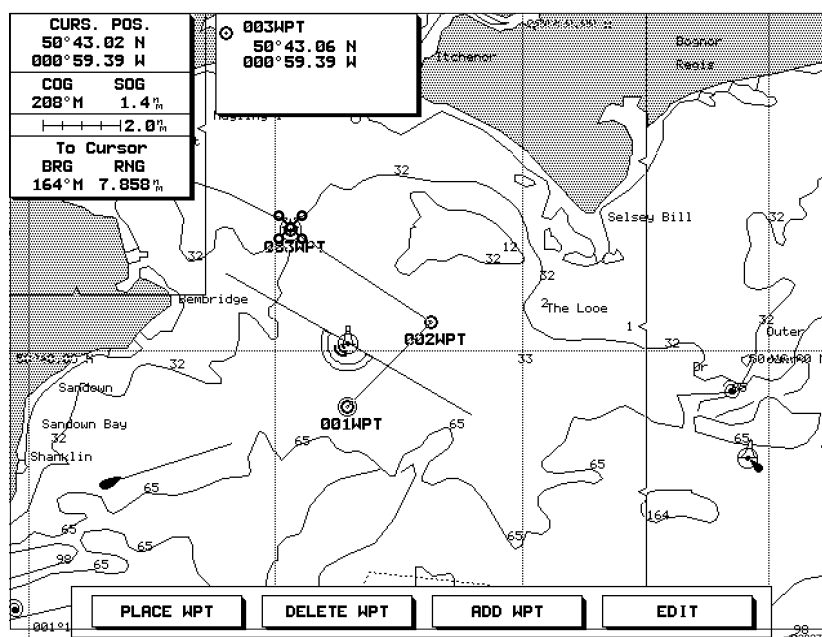

Setting Up and
Using On-Screen
Routes

10. When you have entered all your waypoints, press **CLEAR** to return to the default display.

Your route is displayed on the screen, but is not active.

- To add waypoints to a route using an external device such as the NavPlotter 100, use the MAKE/EDIT option as described above. You can then add waypoints using either the cursor and the PLACE WPT key, or using the external device. When an external waypoint is received, the cursor is positioned on it and the chart is centered.

Editing an Existing Route On-Screen

You can edit the current route, even if it is active. You do this using the same screen you used for entering a new on-screen route.

- To add waypoints to the end of an existing route:
 1. Press the ROUTE soft key to display the Route menu and the current route selection.
 2. Use the trackpad, or press the ROUTE soft key, to highlight the MAKE/EDIT option, and press **ENTER**.

The cursor is connected to the last-placed waypoint with a dotted line, ready to add further waypoints to the route in the same way as for a new route.

You can now add, delete or insert waypoints, although you cannot delete a waypoint if you are tracking towards it.

Note: You can also use this option to delete waypoints that are not part of the current route, if you have selected the waypoint display option when you set up your chartplotter (see *Chapter 6*).

- To delete a waypoint:

Note: *You cannot delete a waypoint if it is used in another route.*

1. Use the trackpad to position the cursor over the waypoint you wish to delete, until the data for that waypoint is displayed in the object data box.
2. Press the DELETE WPT soft key.
3. Press **ENTER** to confirm the deletion, if the waypoint is used in a route.

The waypoint disappears from the screen. If the waypoint was not at the end of the route, then the waypoints before and after the deleted waypoint are connected with a straight line.

Press **CLEAR** to return to the default display.

- To insert an additional waypoint in a route:

1. Position the cursor on (or close to) the line between two existing waypoints.
2. Press the ADD WPT soft key. The line changes from a solid line to a dotted line. (If the chartplotter beeps instead, move the cursor closer to the line and press ADD WPT again.)
3. Move the cursor to the required position. Dotted lines connect the cursor to the two existing waypoints.
4. Press **ENTER**. The new waypoint is placed, and named with the first available waypoint number.

Press **CLEAR** to return to the default display.

Editing Route Information

Once you have created a route, you can edit the route information, including the route name and the waypoint names, symbols and positions.

- To edit the route information for the currently selected route:

1. Press the EDIT soft key from the MAKE/EDIT screen of the ROUTE menu.

A summary of the current route is displayed on the screen, and the soft key labels change, as shown in the following example.

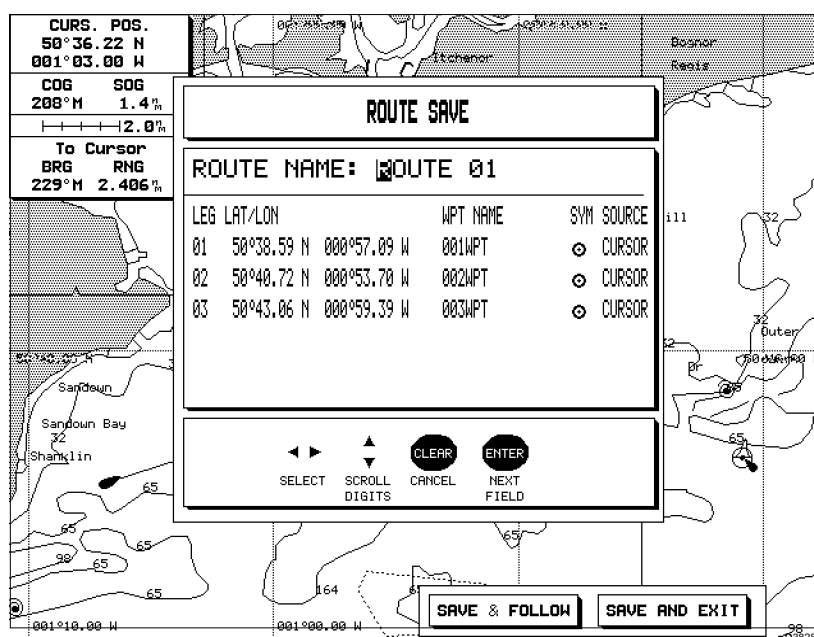

Setting Up and
Using On-screen
Routes

The route name is shown at the top of the route summary. For each waypoint you placed, the following information is given:

Leg The leg number

Position The position of the waypoint for this leg, as selected by the cursor position when you made the route. The position is given as either latitude and longitude or TDs, depending on your setup selection.

WPT Name The waypoint name. The default name is in the format *xxxWPT*, where *xxx* is the waypoint number. You can give the waypoint a name of up to 16 characters, which can be letters and/or numbers. Depending on your setup selection, the full name, the first 3 or the first 6 characters, or no characters are displayed on the chart. Waypoints are listed in the Waypoint List in alphanumeric order of name (see Chapter 4). If you plan to use the Waypoint List, you may wish to name related waypoints so that they are grouped together in the list.

Sym The waypoint symbol. The default is a circle, but you can change it to any of the mark/event symbols (see page 35).

Source The source of the position information. For on-screen routes, this is always the cursor. If you edit the position, the source is updated to "EDIT".

You can change the route name or the waypoint positions, names or symbols.

2. Use the left or right sides of trackpad to move the cursor to the number, letter or symbol you wish to change. You can hold the trackpad down to move quickly, or press **ENTER** to skip to the start of the next field.
3. Use the top or bottom of the trackpad to increase or decrease the number, or change the letter or symbol.
4. Repeat steps 2 and 3 until the required information is displayed.
5. When you have finished editing the data, you can **either**:
 - Press the **SAVE & EXIT** soft key to save the changes and return to the default screen
or
 - Press the **SAVE & FOLLOW** soft key to save the changes, return to the default screen, and start navigating towards the first waypoint.

Using a Route

Once you have set up or selected a route, you can perform the following tasks:

- Follow or “initiate” the route (that is, start tracking towards the first waypoint)
- Retrace a route by following it in reverse order
- Advance to the next leg of the route
- Erase the route

You can also edit the route, even if it is active, as described above.

Note: If you have two chartplotters on your system, the active route on one unit is also displayed on the second unit, where it will always appear as Route 00. You can use the Route menu options on the second unit to control the route tracking on the first unit.

Following, Reversing and Stopping a Route

Once you have set up a route, you can start navigating towards the first waypoint or, if you are retracing the route, the last waypoint.

- If you did not initiate the route using the **SAVE & FOLLOW** soft key from **MAKE/EDIT**, you can do so as follows:
 1. If the Route menu is not already displayed, press the **ROUTE** soft key to display it.
 2. If the required route is not displayed, press **SELECT** until the route is displayed.
Check the route display to confirm which waypoint will become active: this waypoint is displayed on the screen with a circle round it.



3. If you wish to follow the route in the reverse order, use the trackpad or the RTE soft key to highlight the REVERSE option, and press **ENTER**. The circle moves to the waypoint at the opposite end of the route.
4. Use the trackpad or the ROUTE soft key to highlight the FOLLOW option, and press **ENTER**.

The chartplotter navigates towards the waypoint, unless a waypoint is already active.

If you are already navigating to a waypoint (either by following a route or using the GO TO option), a warning message is displayed (see page 23).

- To stop following the current route, select the OFF option from the ROUTE menu. This option replaces the FOLLOW option when the route is already active.

Advancing to the Next Leg of the Route

When you reach the active waypoint, the chartplotter will automatically start tracking towards the next waypoint in the route.

If you have set the Arrival Alarm when you set up your system, the alarm buzzer sounds and a message is displayed when either of the following conditions is met:

- The distance to the target point is less than that specified for the Arrival alarm.
- Your vessel reaches the closest point of approach to the target (that is, it crosses the perpendicular to the track, and through the target).

The alarm is cleared after 7 seconds. You can clear the alarm earlier by pressing any key.

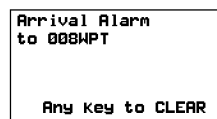

D3832-1

- You can also advance to the next leg even if you have not reached the current waypoint. From the ROUTE menu, highlight the NEXT LEG option and press **ENTER**. The chartplotter will start tracking from the vessel's current position towards the next waypoint.

Erasing a Route

The chartplotter can store up to 20 routes. If you have used all the route slots and want to create a new route, you can erase a selected route.

Note: If required, you can store routes on a Memory C-Card for future use, as described in Chapter 6, before deleting them from the chartplotter's memory.

- To erase an existing route:
1. Press the ROUTE soft key to display the Route menu.
 2. Press SELECT until the required route is displayed.
 3. Use the trackpad or ROUTE soft key to highlight the ERASE option, and press **ENTER**.
 4. Press **ENTER** to confirm the deletion.

The route disappears from the screen, and the route soft keys are cleared.

Note: *If you have set the waypoint display on when you set up your chartplotter (see Chapter 6), all the waypoints are displayed. Otherwise, only the waypoints for the current route are displayed, so the waypoints for the deleted route disappear.*

Setting Up and
Using On-Screen
Routes

3.4 Measuring Distances Using the RULER Key

- You can obtain an accurate measurement of the distance between two points by using the RULER soft key, as follows:

1. From the default soft key display, press the RULER soft key.
The soft key labels change, as shown in the example below.
2. Use the trackpad to move the cursor to the measurement start point.
3. Press FROM. The start point is marked with an “F”.
4. Use the trackpad to move the cursor to the measurement end point. A dotted line connects the From point to the cursor.
5. Press TO. The end point is marked with a “T”.

A dotted line connects the two points, and a ruler data box is displayed.

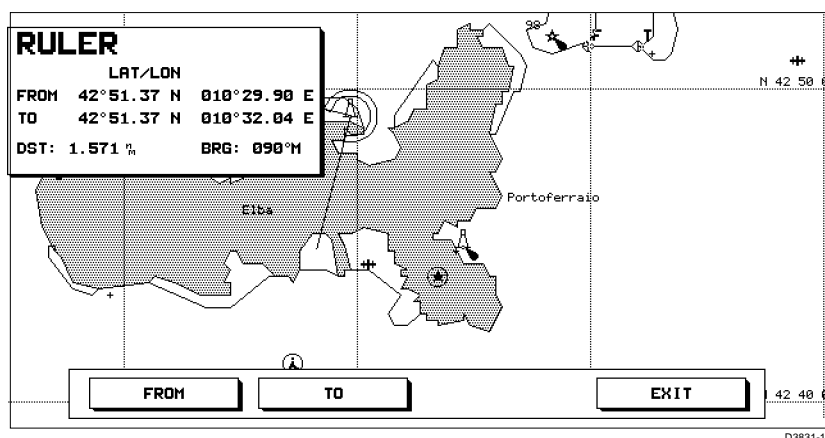

6. If required, repeat with further FROM and TO positions. The ruler information is updated each time you select a new FROM or TO location.
7. Press **CLEAR** or EXIT to clear the ruler display and return to the default screen.

Chapter 4: Additional Basic Functions

4.1 Introduction

This chapter explains how to use some further basic functions available on the chartplotter, using the dedicated keys and the menus.

To get the most out of your chartplotter, you should set up the basic data and customize the display, as described in Chapter 6. Once you have explored the display possibilities, you may wish to return to the customization and make further changes (see *Section 6.3*).

This chapter covers the following topics:

- Using marks and events
- Recording and displaying track histories
- Man Overboard (MOB)
- Controlling alarms and timers

4.2 Marks and Events

The chartplotter allows you to place symbols to record marks or events. You have a choice of 16 symbols that can be used for both marks and events.

Marks and events differ in the following ways:

- **Marks** are used to record features at the cursor position, such as fishing buoys and anchorages. They are only graphical marks, and you cannot edit them or add information.

The Danger Zone mark (☒) has an associated invisible *exclusion zone* around it. You can specify the radius of the exclusion zone as part of your setup procedure (see *Section 6.2*). For the first nine danger zones, if your vessel enters the zone, an alarm will sound.

- **Events** are used to record features at your vessel's current position, such as a good fishing spot.

Events are special waypoints. The chartplotter assigns a unique identifier to each event, in the format *xxxEVT*, where *xxx* is the next available number. The events are stored in the waypoint list, and can be recalled and edited later (see *Chapter 5*).

Up to 1000 marks can be displayed on the screen at one time, and up to 1000 events or waypoints.

Placing and Deleting a Mark

► To place a mark symbol at the cursor position:

1. Press the **MARK** key.

The soft key labels change, as shown in the example on the following page.

The current mark symbol is shown below the cursor data box at the top left of the screen.

2. If you wish to choose a different symbol for your new mark, press the **SELECT SYMBOL** soft key. The Mark Symbols dialogue box is displayed in the centre of the screen.
3. Use the trackpad to move around the symbols until the required symbol is highlighted, and press **ENTER**.

The dialogue box is removed, and the new symbol is displayed under the cursor data box.

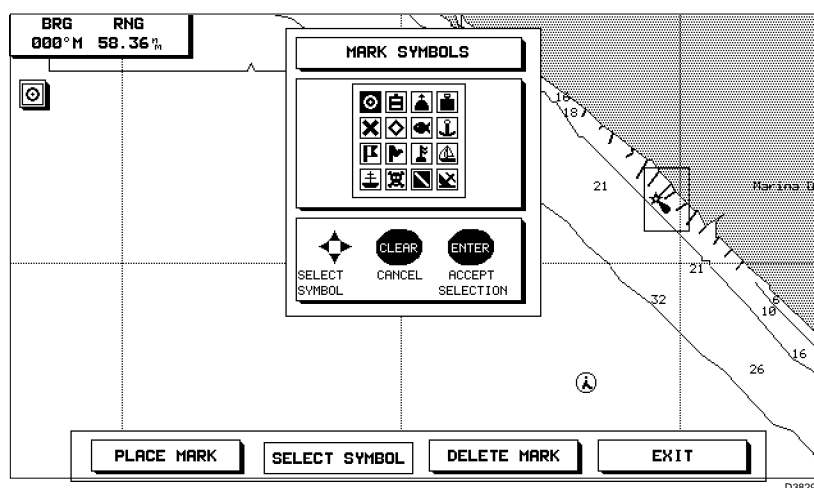

4. Position the cursor at the point where you wish to place the mark.
5. Press the **PLACE MARK** soft key to place the new mark at the cursor position.
6. Press **EXIT** or **CLEAR** to return to the default screen.

► To delete a mark:

1. Press the **MARK** key, to display the Mark soft key labels.
2. Position the cursor over the mark you wish to delete.
3. Press the **DELETE MARK** soft key to delete the mark.
4. Press **EXIT** or **CLEAR** to return to the default screen.

Placing and Deleting an Event

- The procedure for placing an event is the same as for placing a mark, except that you use the **EVENT** key and the event is always placed at the vessel's position. The event is marked with an event name in addition to the event symbol.

If the sea temperature and depth are available they are recorded with the event.

- The procedure for deleting an event is the same as for deleting a mark, except that, since events are special waypoints, you are prompted to confirm the deletion.

4.3 Using Track Histories

The chartplotter **TRACKS** function allows you to mark on the chart the actual route that your vessel has followed, as if it had left a visible fixed wake.

While the track is turned on, it is recorded in the chartplotter's memory, and can be retrieved and displayed later if required. For example, you may wish to display a previous track, and then use the **Route** option to place waypoints along it that you can then track towards.

You can store up to 5000 track points in total, in up to 5 track files. The chartplotter issues a warning when 4000 points have been stored. The track files can be stored in memory or downloaded to a Memory C-Card (see Chapter 6). Files can be retrieved for display at a later date. Up to 5 track history files, including the current track, can be displayed on screen at one time.

The length of track that can be displayed is limited by the frequency of the track points. The more frequent the track points, the more accurate the track recorded, but the more memory is required. If you wish to display and record a long track, you may need to increase the gap (interval) between points. Otherwise, once the memory is full, track points will start to disappear from the beginning of the track.

The chartplotter allows you to specify the track interval, in terms of either distance or time.

You can check the number of track points recorded for each track file, by displaying the **Tracks Edit** window as described below.

Starting and Stopping a Track

- To start and stop a track:
 1. From the default soft key display, press the **MENU** key to display the main menus.

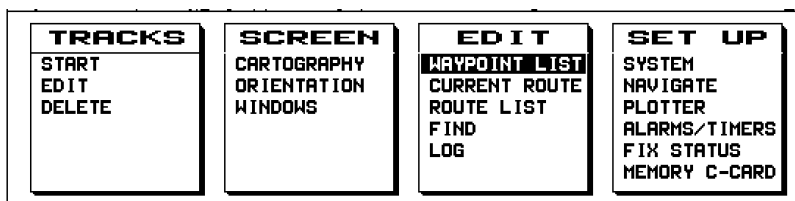

2. Use the trackpad or press the TRACKS soft key to highlight the START option, and press **ENTER**.
The option changes to STOP, indicating that Track History is turned on, and the chartplotter starts laying down track marks.
The track data is stored in the track file that is set as the current track (see below).
3. If you wish to turn Track History off again, highlight the STOP option and press **ENTER**.
4. Press **CLEAR** to clear the menus.

Deleting the Current Track

Deleting a track clears all the track history data from the selected file, ready to use it for new data.

- To delete the current track:
 1. From the default soft key display, press the **MENU** key to display the main menus.
 2. Use the trackpad or press the TRACKS soft key to highlight the DELETE option, and press **ENTER**.
 3. Press **ENTER** again to confirm the deletion.
The track data in the current track file is deleted.
If the track is currently active, the old data is cleared from the file and the screen, but any new track history information is still stored in the current file.
 4. Press **CLEAR** to clear the menus.

Editing Track Controls

The EDIT option on the Tracks menu allows you to edit the controls for the current track and also any other tracks stored in memory. You can:

- Select one or more track histories for display.
- Change the track file for the current track history data. If you do this while the track history is switched on, the chartplotter stops storing track data to the original track file, and starts storing it in the new file.

- Change the track interval for the current track. You can select one of the following intervals:
 - 1, 5, 10 or 30 seconds
 - 1, 3, 5, 10 or 30 minutes
 - 0.1, 0.5 or 1.0 nm
 - Start or stop a track history, or delete a selected track. These options perform the same functions as the START/STOP and DELETE options from the TRACKS menu.
- To edit the controls:
1. From the default soft key display, press the **MENU** key to display the main menus.
 2. Use the trackpad or press the TRACKS soft key to highlight the **EDIT** option, and press **ENTER**. The Track History screen is displayed.

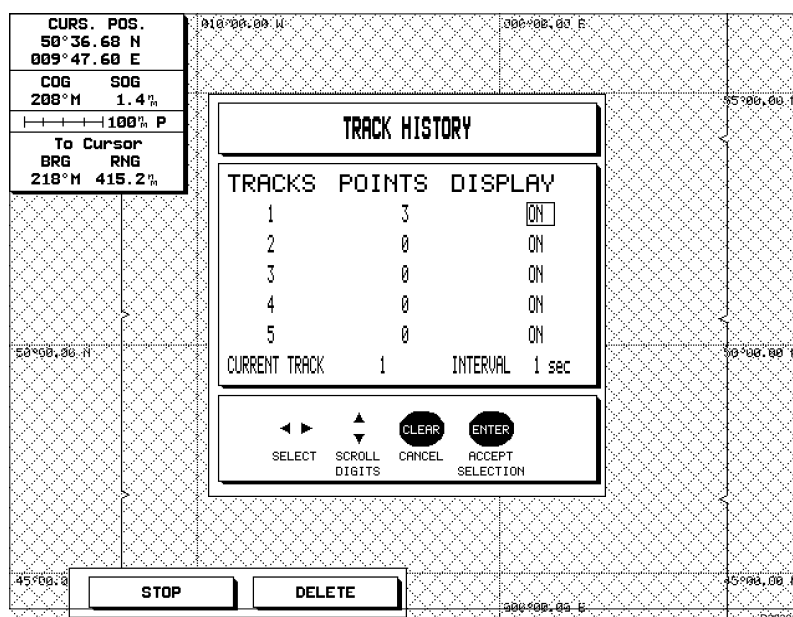

3. Use the trackpad sides to scroll around the fields, and the trackpad top and bottom to change the settings.
You can toggle the Display option on or off for any track, change the current track file number, and change the track interval for the current track.
4. If required, press the START/STOP soft key to turn the current track on or, if it is already on, to turn it off.
5. To delete a track, move to the Display field of the track you wish to delete, and press the DELETE soft key. Press **ENTER** to confirm the deletion.
6. Press **ENTER** to accept your selections and return to the default display, with the new track settings.

4.5 Man OverBoard (MOB)

If you lose a person or object overboard, and need to return to the location, you should use the Man OverBoard (MOB) function at once.

- To initiate the MOB procedure, press and hold the **MARK** key for two seconds.

The chartplotter then performs all the following tasks automatically:

- Marks the vessel's position, and displays the MOB symbol, with the position assigned as waypoint 1000.
- Switches to a range scale of 0.05nm per inch, in North Up mode. If Plotter Mode is switched off (see Section 6.3), the display then changes to the nearest range scale for which cartographic information is available.
- Places the cursor over the MOB waypoint, and displays the MOB symbol and position (Lat/Long or TDs) in the object data box.
- Starts (or resets) the elapsed timer, which is displayed in the cursor data box.
- Uses the MOB position as the destination waypoint, indicated by a circle around it.

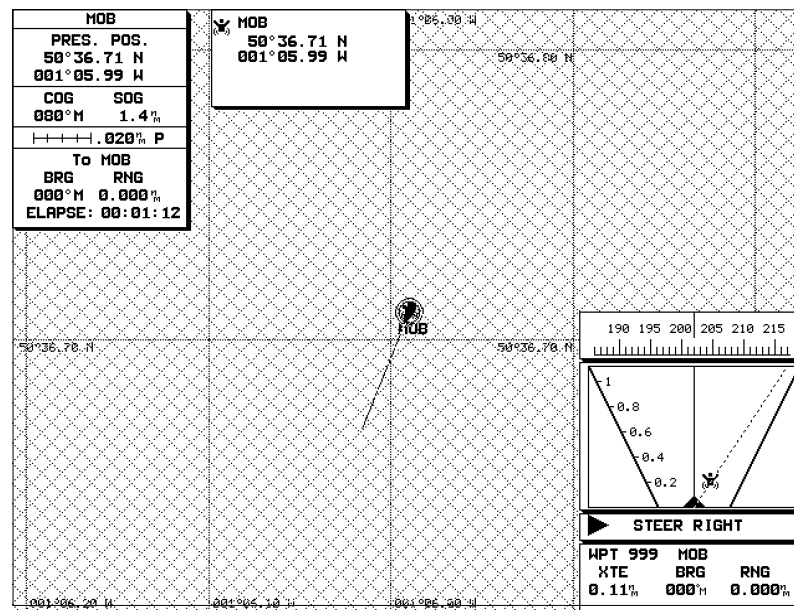

Note: The MOB procedure can also be initiated or cancelled if the appropriate SeaTalk message is received by the chartplotter.

- To cancel the MOB procedure, press and hold the **MARK** key for two seconds again.

4.6 Alarms and Timers

The chartplotter reports the following alarms:

Alarm	Indicates:
Arrival	Your vessel has arrived at the active waypoint, it has either: broken the arrival circle (the radius of which is set in Set Up) or, is perpendicular to the route leg through that waypoint.
Off course	Your vessel has exceeded the specified distance (set in Set Up) from the active route leg.
Anchor	Your vessel has moved from its anchor position by more than the distance specified in Set Up.
Countdown	The countdown timer has reached zero.
Clock	The time matches the alarm time set in Set Up.
Danger zone	Your vessel has entered the danger zone circle (the radius of which is set in Set Up) for the danger mark (☒).
Fix status	The chartplotter is no longer receiving position information from GPS, dGPS or Loran.

The alarms are switched on or off, and the limits set, using the ALARMS/TIMERS option from the Set Up menu (see Chapter 6). This option also controls the elapsed time counter, which displays the time elapsed since the last reset in the cursor data box.

When an alarm is triggered, the alarm buzzer sounds and a window such as the following is displayed:

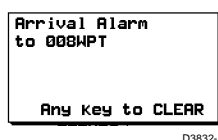

- To silence the alarm and clear the message, press any key. Alternatively, wait 7 seconds for the alarm to time out.

No action is taken by the chartplotter except for the Arrival Alarm. If you press a key, or after 7 seconds, the chartplotter starts tracking to the next waypoint. Alternatively, if you have arrived at the last waypoint in the route, the chartplotter stops tracking.

Note: The chartplotter also repeats any SeaTalk alarms it receives, such as Depth and Wind alarms.



Chapter 5: Using Stored Lists (EDIT)

5.1 Introduction

The chartplotter allows you to perform a number of tasks using the information you have saved. This information includes waypoints, routes, events, track histories and the log.

This chapter explains how to view, edit, use and print the stored information using the EDIT main menu.

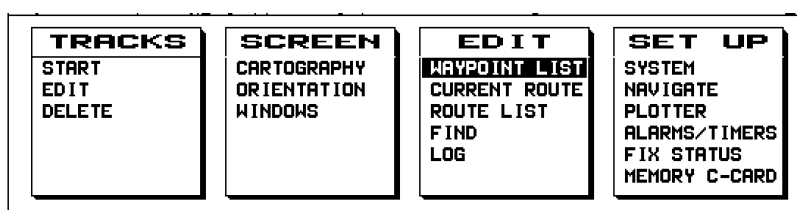

The tasks you can perform from this menu include:

- Finding and selecting an existing waypoint to steer towards immediately
- Adding a new waypoint or editing the details of an existing waypoint
- Making a new route by selecting existing waypoints from the waypoint list
- Selecting an existing route and starting to follow it
- Reviewing the route you are currently following, and moving on to the next leg
- Displaying calculated estimated times of arrival at waypoints, based on either current or planned speed over the ground

This chapter covers the following information:

- The Waypoint List
- The Current Route details
- The Route List
- Finding a waypoint
- Viewing the Log
- Printing

Controlling and displaying track histories is described in Chapter 4.

5.2 The Waypoint List

Whenever you create a waypoint, it is added to the Waypoint List. The Waypoint List also includes any events you have marked, which have default names of the format xxxEVT, and waypoints sent from a master chartplotter as part of the active or selected route.

This option allows you to perform the following tasks:

- View the Waypoint List
- Find a waypoint of known name, and display its details
- GO TO a selected waypoint
- Delete a waypoint
- Edit the details of an existing waypoint, or add a new waypoint

Viewing the Waypoint List

- To view the list:
 1. Press **MENU** to display the main menus.
 2. Use the trackpad, or press the EDIT soft key, to highlight the WAYPOINT LIST option on the EDIT menu.
 3. Press **ENTER**. The Waypoint List screen is displayed:

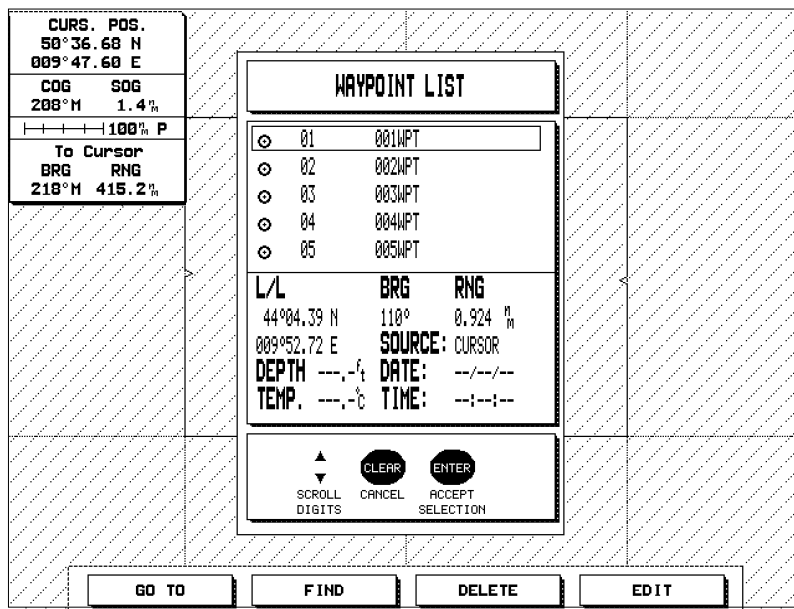

The list shows the waypoint symbol, number (assigned by the chartplotter) and name for each waypoint. The waypoints are listed in alphanumeric order of waypoint name.

The box below the list gives the following details for the highlighted waypoint:

- Position, in either latitude and longitude or TDs, depending on your setup
 - Bearing and range from your vessel's current position
 - Source of position data (cursor, edit, GPS etc)
 - Depth and temperature when the event waypoint was created, if available
 - Date and time that the waypoint was created
4. Use the trackpad up and down edges to move up and down the list, displaying the details for each waypoint in turn.

Waypoint List Operations

With the Waypoint List displayed, you can use the soft keys to perform the following tasks:

- GOTO** Starts tracking towards the highlighted waypoint. The Waypoint List is cleared and the chart is displayed.
- FIND** Finds a specified waypoint in the Waypoint List (see below).
- DELETE** Deletes the highlighted waypoint from the list. If the waypoint part of an existing route, press **ENTER** to confirm the deletion.
- EDIT** Allows you to edit the highlighted waypoint, or add a new waypoint (see below).

Note: You cannot delete an active waypoint.

Finding a Waypoint in the List

- To find a waypoint in the list:
1. Press the FIND soft key. The Find Waypoint window is displayed, with the currently highlighted waypoint name and symbol displayed.

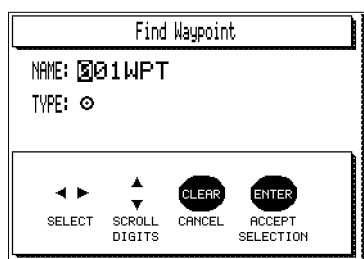

D3813-1

2. Use the trackpad left and right edges to move to the first position in the waypoint name that you wish to edit.
3. Use the up and down edges to change the value. The chartplotter tries to match the waypoint as you change each character (from left to right), and provides the nearest character for which there is a match in the waypoint list.

The symbol (“Type”) is updated to match the waypoint selected: you cannot edit this field.

4. Press **ENTER** to accept your selection. The Waypoint List is redisplayed, with the selected waypoint highlighted.

Note: You can find a waypoint on the chart using the FIND option from the EDIT menu (see section 5.5).

Editing a Waypoint or Adding a New Waypoint

- To edit an existing waypoint or add a new waypoint:
 1. Display the waypoint list as described above.
 2. Use the trackpad to highlight the waypoint that is either:
 - The waypoint you wish to edit, or
 - A waypoint with similar details to the new waypoint you wish to create.
 3. Press the EDIT soft key. The Edit Waypoint window is displayed, with the details of the selected waypoint.

CURS. POS. 50°36.68 N 009°47.60 E	
COG SOG 208°M 1.4%	
100% P	
To Cursor BRG RNG 218°M 415.2%	

WAYPOINT LIST

EDIT WAYPOINT

Name:

SYMBOL:

LAT: 44°04.39 N

LON: 009°52.72 E

D3814-1

4. If you wish to add a new waypoint, press the NEW soft key. The waypoint name changes to xxxWPT, where xxx is the next available waypoint number. The other details remain the same.
5. You can edit the waypoint name, symbol and position. Use the trackpad to move to the character you wish to edit, and change the value.
6. When you have finished your edits, press **ENTER** to save the information and return to the Waypoint List, or **CLEAR** to abandon your changes.

The Waypoint List

5.3 The Current Route

The Current Route option allows you to view the currently selected route, with progress details, and to specify a planned Speed Over the Ground (SOG) to obtain an estimated time of arrival (ETA). You can also advance to the next leg of the route from this screen.

This option is useful when planning routes, for example for checking the speed required to reach a waypoint when the tide is right.

Viewing the Current Route

- To view the Current Route information, select the CURRENT ROUTE option from the EDIT menu.

The Current Route screen is displayed, as shown below.

The screenshot shows the 'CURRENT ROUTE 1' screen with the following data:

CURS. POS.	
50°36.68 N	009°47.60 E
COG SOG	
208°M	1.4 ^M / _H
-----100% P	
To Cursor	
BRG	RNG
218°M	415.2 ^M / _N

CURRENT ROUTE 1		
CURRENT SOG: 1.0 Kts		
01	006WPT	
02	007WPT	
03	008WPT	
04	009WPT	
L/L	LEG BRG	LEG DIST.
44°03.70 N	179°	0.571 ^M / _N
009°51.85 E	ETA:	--:--
ELAPSE TIME:		--:--
TOTAL DISTANCE COV.: 0.0 Nm		

▲ CLEAR ENTER
 ▼ SCROLL CANCEL ACCEPT
 DIGITS SELECTION

NEXT LEG PLANNED SOG

The Current Route

The Current Route screen lists the waypoints for the current route, showing the waypoint symbol, number (assigned by the chartplotter) and name for each waypoint. The box below the list gives the following details for the highlighted waypoint:

- Position, in either latitude and longitude or TDs, depending on your setup
- Range and bearing from your vessel's position
- Estimated time of arrival (ETA) at the waypoint
- Total time elapsed since the start of the route
- Total distance covered since the start of the route

The ETA predictions are based on either the current or planned speed over the ground (SOG), as displayed above the list of waypoints, depending on your selection.

Current Route Operations

With the current route summary displayed, you can use the soft keys to perform the following tasks:

- | | |
|----------------|--|
| NEXT LEG | Jumps to the next leg of the route. This has the same effect as the NEXT LEG option from the ROUTE default soft key menu. |
| PLANNED SOG | Switches from Current SOG to Planned SOG to calculate the ETA for each waypoint.
The Planned SOG value is displayed above the waypoint list instead of the Current SOG, and the ADJUST SOG soft key becomes available so that you can change the planned SOG value. |
| or CURRENT SOG | Switches from Planned SOG to Current SOG to calculate the ETA for each waypoint. |
| ADJUST SOG | This soft key is only available if you have already selected the PLANNED SOG option, and displays the Planned SOG window. Use the trackpad to adjust the value, and press ENTER to accept the new value. |

5.4 The Route List

Whenever you create a route, its details are added to the Route List. You can store data for up to 20 routes in the chartplotter's memory.

The Route List option allows you to perform the following tasks:

- View the Route List
- Display and edit the waypoints for a selected route
- Display a selected route on the chart
- Follow or reverse a selected route
- Delete a route
- Edit the details of an existing route, or construct a new route by selecting existing waypoints

You select the option and make the edits in the same way as described for the Waypoint List option (see Section 5.2).

Viewing the Route List

► To view the Route List:

1. Select the ROUTE LIST option from the EDIT menu.

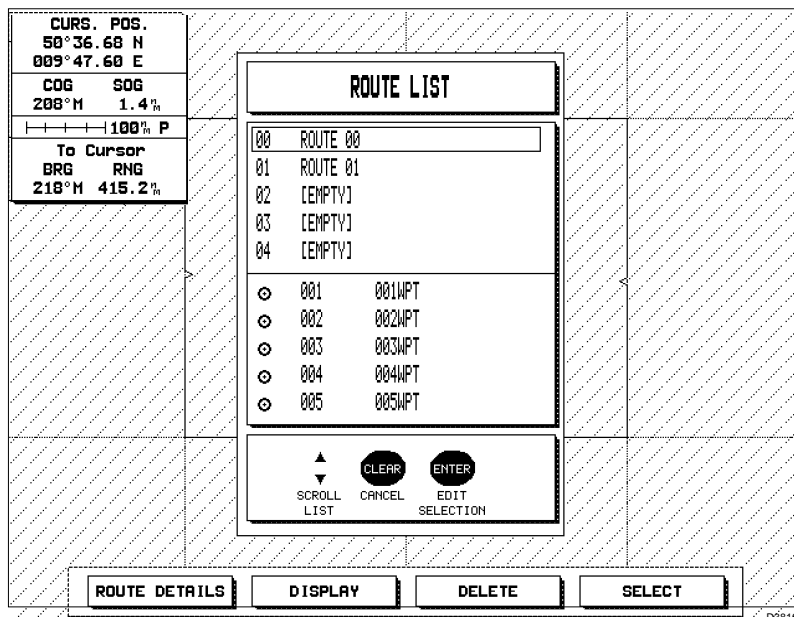

The first 5 waypoints are listed for the currently highlighted route.

2. Use the trackpad up and down edges to scroll up and down the list.
3. If you cannot identify a route from its name and the first 5 waypoints, you can display it on the chart as described below.

Route List Operations

When the Route List is displayed, you can use the soft keys to display, delete, or follow a selected route, and display the details of the waypoints that make up the route:

- | | |
|---------------|--|
| ROUTE DETAILS | Displays the details of all the waypoints in the selected route, in the same format as the Waypoint List (see below), and allows you to follow the route or access the Route Edit screen |
| DISPLAY | Displays the <i>selected</i> route (see SELECT below) on the chart at an appropriate scale. After 7 seconds, the display returns to the Route List. |
| DELETE | Deletes the highlighted route. Press ENTER to confirm the deletion. Note that this only deletes the route from the route list – it does not delete the component waypoints. |
| SELECT | Selects the route so that it can be displayed or activated. When a route is selected, the SELECT soft key is replaced by either the FOLLOW soft key or, if the route is already active, the OFF soft key. |
| or FOLLOW | This soft key is displayed instead of SELECT if the highlighted route has been selected and is not already active. It activates the selected route, tracking towards the first waypoint. This has the same effect as the FOLLOW option from the ROUTE default soft key menu. |
| or OFF | Note that you can also reverse, select and activate a route from the Route Details screen (see below).

This soft key is displayed instead of SELECT or FOLLOW if the highlighted route has been selected and is active. It turns off the selected route. |



Route Details

- To display the details of the currently highlighted route:
 1. Press the ROUTE DETAILS soft key. The Route Details screen is displayed.

CURS. POS. 50°36.68 N 009°47.60 E COG SOG 208°M 1.4 % 100% P To Cursor BRG RNG 218°M 415.2%	ROUTE: ROUTE 00 01 001WPT 02 002WPT 03 003WPT 04 004WPT 05 005WPT L/L BRG RNG 44°04.39 N 092° 0.712 % 009°52.72 E SOURCE: CURSOR DEPTH DATE: 01/01/70 TEMP. TIME: 00:00:00 ▲ CLEAR ENTER ▼ SCROLL CANCEL EDIT LIST SELECTION REVERSE SELECT
--	---

This displays the details of the waypoints in the route, in the same format as the Waypoint List (see Section 5.2).

2. You can press the REVERSE soft key to reverse the order in which the waypoints will be followed in the route, and the SELECT then the FOLLOW soft key to start following the route. The soft key label is updated to OFF.
3. Press **CLEAR** to return to the Route List, or **ENTER** to go to the Route Edit screen (see below).

Editing a Route or Building a New Route

You can edit an existing route, or build a new route, simply by selecting existing waypoints from the list.

- To edit an existing route or build a new route:
 1. Display the Route Edit page, either:
 - From the Route Details screen, by pressing **ENTER**, or
 - From the Route List, by highlighting the required route and pressing **ENTER**. Highlight an empty route if you wish to build a new route.

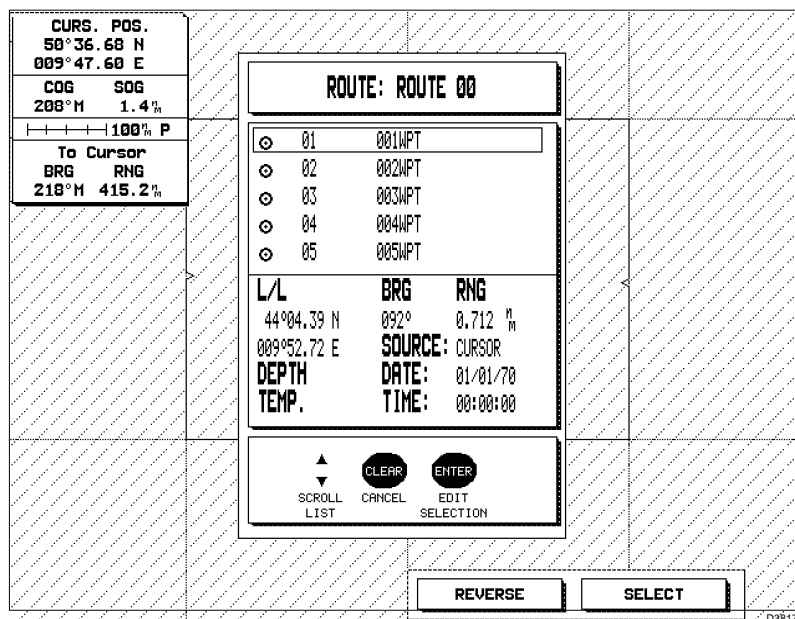

The right side of the screen shows the Route Details window, and the left side shows the Waypoint List window.

Initially, cursor control is in the Route Details window.

2. Use the trackpad to highlight the position in the Route Details list where you wish to insert or delete a waypoint.
3. To delete a waypoint from the route, press the DELETE soft key.
4. To add a waypoint to the route:
 - a. Press the left side of the trackpad to move into the Waypoint List window.
 - b. Scroll up or down the list until the required waypoint or location is highlighted.
 - c. To find a specific waypoint, press the FIND soft key. The Find Waypoint window is displayed, as described in Section 5.2.
 - d. When you have found the required waypoint, press the ADD WPT soft key to add the waypoint to the route.

If you are inserting the waypoint into an existing route, the new waypoint is inserted immediately after the highlighted location, and all the other waypoints in the route are moved down the list. The new waypoint is now highlighted in the route list.
 - e. Control stays in the Waypoint List window, so you can continue to select waypoints and add them to the route.
 - f. Press the right trackpad edge to return control to the Route Details window.

If you made a mistake, you can use the DELETE soft key to remove the waypoint(s) from the route.

5. Press the EDIT RTE NAME key to edit the route name. Use the trackpad to change the letters and numbers, and press **ENTER** when you have finished.
6. When you have finished editing the route, press **ENTER** or **CLEAR** to return to the Route List.

5.5 Finding and Displaying a Waypoint

The FIND option on the EDIT menu is used to display a specified waypoint (or event) on the chart.

► To find a waypoint:

1. With the main menus displayed, use the trackpad or the EDIT soft key to highlight the FIND option on the EDIT menu. Press **ENTER**.

The Find Waypoint screen is displayed, as shown below. The waypoint name is the first name in the Waypoint List.

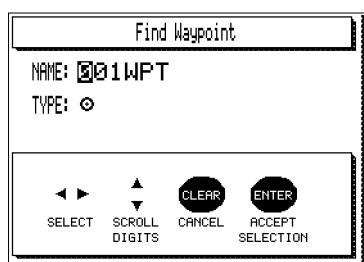

2. Use the trackpad to edit the waypoint name, starting with the left-most character. As you change each character, the chartplotter displays the nearest match from the Waypoint List, and updates the waypoint symbol (“Type”) as appropriate.
3. When the required waypoint name is displayed, press **ENTER**.
The chart is repositioned, with the waypoint displayed in the centre of the screen. The waypoint data is shown in the object data box.

Finding and Displaying a Waypoint

5.6 Displaying and Printing the Log

A log entry is created every 30 minutes and the log keeps data from the last 24 hours.

- To display the log, select the LOG option from the EDIT menu.

The list shows the date and time of each log entry, plus the following details for the highlighted entry:

- Vessel's position
- Course Made Good (CMG) and Distance Made Good (DMG) since the previous log entry.

Use the trackpad to scroll up or down the list.

- To print the log, check that your printer is connected and on-line, and press the PRINT soft key.

Note: *You cannot edit the log.*

5.7 Printing

The chartplotter provides a Print function that allows you to print any display.

Before using the option, check that your printer is connected and on-line, and that you have set the baud rate correctly using the System Set Up menu (see Chapter 6).

- To print a screen, press and hold the **DISPLAY** key for 5 seconds. At the end of this time, the chartplotter beeps 3 times, the cursor disappears, and the display information is sent to the printer.

Chapter 6: Customizing the Chartplotter

6.1 Introduction

Once you have installed your chartplotter and are familiar with its basic operation, you need to set it up so that it obtains the information from the correct equipment that you have connected it to, operates according to your requirements, and displays information according to your preferences.

This is achieved using two of the Main Menus that are displayed using the **MENU** key: the **SET UP** menu and the **SCREEN** menu.

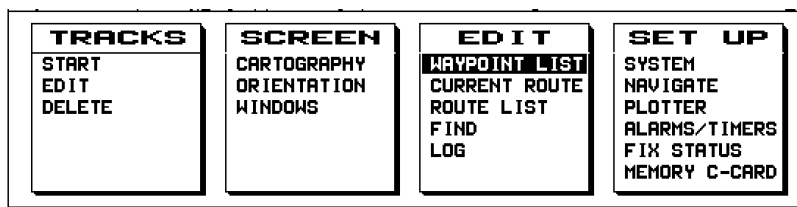

Note: If you have a color chartplotter, the **SCREEN** menu includes a **COLORS** option.

Most of the options will only need to be set up when you first use your system. However, the **SET UP** menu also controls the alarms and timers, which you may wish to change from time to time. In addition, you may decide to change the way you have customized your screen and help levels as you become more familiar with your chartplotter system.

This chapter covers the following topics:

- Setting up the data, including system defaults, alarms and the timer
- Customizing the screen display

6.2 Setting Up the Data

The chartplotter allows you to set up a number of parameters that control the way it operates. These are accessed from the SET UP menu.

The SET UP menu options control the following:

- System set up
- Navigation set up
- Chartplotter set up
- Alarms and timers set up
- Position fixer initial settings and reset
- Memory C-Card transfers

Before you make any changes:

1. Check the lists of parameters and options provided in the tables in this section.
2. Decide what changes, if any, you wish to make.
3. Fill in the required settings in the spaces provided in the tables.

Once you have done this, follow the instructions given below to make the changes.

Changing the Parameters

- To change the set up parameters:
 1. Press the **MENU** key to display the SET UP menu above the right hand soft key. The option you used last is currently highlighted.
 2. Use the trackpad or SET UP soft key to highlight the required menu option, and press **ENTER**.
The requested set up menu is displayed, listing the parameters and their current settings and, for some items, menus of further parameters. For example, the SYSTEM set up menu is shown on the following page.
 3. Use the up and down trackpad controls to move the selection bar up and down the list.
 4. When the required parameter or menu is highlighted, press **ENTER**.
For menus, a further menu of parameters is displayed. Repeat steps 3 and 4 to select a parameter.

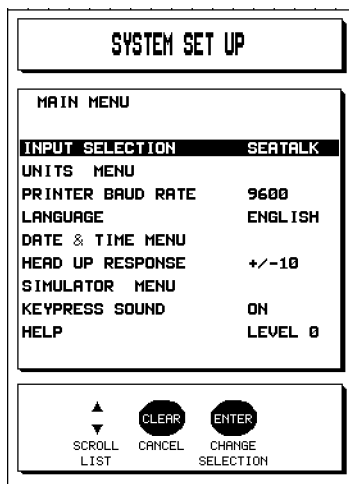

D3836-1

For parameters, a window appears listing the settings available, with the current setting highlighted. For parameters that have a numeric value, a single value (or OFF) is displayed, that can be adjusted.

5. Use the up and down trackpad controls to move the selection bar up and down the list, or to increase or decrease the value. To change a value quickly you can press and hold the trackpad.
6. Press **ENTER** to accept the new setting, or **CLEAR** to cancel the change. The options window is cleared from the menu.
7. Once you have reset all the required values, press **CLEAR**.

If you were in a sub-menu, the previous menu is displayed and you can continue changing parameter settings.

If you were in one of the set up menus, you are returned to the default display.

You can return all the settings to their original factory settings, if required, by performing a master reset, as described in Chapter 8.

Setting Up the System

The **SYSTEM** option from the Set Up menu allows you to set up your system preferences.

The following table lists the System parameters or menus and their options, shows the factory default setting, and provides a space for you to make a note of your new default setting. Each parameter or menu is described in the following subsections.

Parameter/Menu	Options	Factory Default	New Default
Language	English, Italiano, Francais, Deutsch, Espanol, Norge, Svensk, Dutch	English	
Units Menu			
Distance	Nautical miles Statute miles Kilometers	Nautical miles	
Depth	Feet Fathoms Metres	Feet	
Temperature	Centigrade Fahrenheit	Centigrade	
Speed	Knots Miles per hour Kilometers per hour	Knots	
Date & Time Menu			
Time Format	24 hour 12 hour	24 hour	
Time Offset	UTC Local (offset value)	UTC	
Date Format	MMM-DD-YY DD-MMM-YY	MMM-DD-YY	
Simulator Menu			
Speed	Value	1.0 kts	
Heading	Value	000°M	
Starting Point	OFF Position	OFF	
Activate Simulatn	OFF ON	OFF	
Help	Level 0 Level 1	Level 1	
Keypress Sound	OFF ON	ON	
Head Up Response	+/-10 +/-15 +/-20	+/-15	
GPS Input	NMEA NAVAID	NAVAID	
Cursor Transfer	OFF ON	OFF	
Printer Baud Rate	300, 600, 1200, 2400, 4800, 9600	4800	

Language

Select the language in which you wish information to be displayed. The selected language will be used for screen text, labels, menus and options, but will not affect the chart information.

Units

Choose your preferred units for distance, speed, depth and temperature. The units you set will be used to display all data, including information received from other instruments on the system.

Note: The selected language is also used for the set up information. If you set the language incorrectly, English is the first language on the list.

Date and Time

Set your preferred time (12 or 24 hour) and date (month-day-year or day-month-year) format.

Specify either UTC for universal time, or LOCAL and enter the current time offset. The local time offset is retained if you change to UTC, so you can switch between the two easily.

Simulator

The simulator allows you to operate your chartplotter without input data. It generates a display with a moving vessel, so that you can practice using the controls in safety.

- ▶ To set up the simulator:
 1. Adjust the values to the required settings for the speed and heading.
 2. Select the Starting Point option. The chart is displayed.
 3. Move the cursor to the required starting position and press **ENTER**. The set up menu is redisplayed with the starting position data.
 4. Set Activate Simulator to ON.

When it is active, the word “SIMULATE” is displayed at the top of the screen above the cursor data box.

Help

Choose one of the following help levels:

- | | |
|---------|--|
| Level 0 | The default soft key labels are only displayed if a soft key is pressed when no other operation is in progress, and they disappear if no operation is performed for 7 seconds. |
|---------|--|

Level 1 The default soft key labels are displayed if no other operation is in progress.

Keypress Sound

This option controls whether or not the chartplotter beeps when you press a key.

Head Up Response

The Head Up Response controls the damping of the chart rotation when Head Up mode is selected.

The default value is $\pm 15^\circ$, which means that the chart will only be rotated, and the screen redrawn, if your vessel's heading has changed by more the 15° in either direction from the current head up display. Select ± 10 for a more frequent response, or ± 20 for a less frequent response.

GPS Input

The chartplotter can receive position data via a SeaTalk, NAVAID or NMEA connection. Where position information of more than one data standard is available, SeaTalk will always take precedence. You can select whether NAVAIDS or NMEA has next priority.

Cursor Transfer

If you have another chartplotter connected, you can set up your system so that the chartplotters can display each other's cursor.

Printer Baud Rate

Select the baud rate required by your printer. Refer to your printer manual for further information.

Setting Up the Navigation Data

The NAVIGATE option from the Set Up menu allows you to set up your navigation preferences .

The following table lists the Navigate parameters and their options, shows the factory default setting, and provides a space for you to make a note of your new default setting. Each parameter is described in the following subsections.

Parameter/Menu	Options	Factory Default	New Default
Heading	Magnetic True	Magnetic	
Magnetic Variation	AUTOMATIC Value, + or - in 0.1° steps	AUTOMATIC (value)	
Position resolution	.00 .000 TD	.00	
TD Settings Menu			
GRI		9970	
Slave 1		W	
Slave 2		W	
ASF 1		+0.0	
ASF 2		+0.0	
Alternate Solution		OFF	
Map Datum		WGS 1984	
Fix Datum		WGS 1984	
Position correction		No correction	

Heading

Select either degrees magnetic or degrees true for your heading data. The units you set will be used to display all heading data, including information received from other instruments on the system.

Magnetic Variation

The default setting for magnetic variation is Automatic, which means that the variation value is computed from a world magnetic model for the year and current position of the boat.

If no position is available, you can set a specific variation value. Use the trackpad to change from Automatic to a value, and increase or decrease the value in 0.1° steps. Press and hold the trackpad to change the value quickly.

Position Resolution

When working with position information in latitude and longitude, you can display any position data to either two or three decimal places. Alternatively, you can select TD to display all your position information in Loran TDs.

TD Settings Menu

If you are using a Loran position fixer, set the TD parameters to the required values.

The chartplotter allows you to select the following GRI numbers for active Loran chains:

GRI	Chain
4990	
5930	Canadian East Coast
5970	
5990	Canadian West Coast
7170	
7930	
7960	Gulf of Alaska
7970	
7980	Southeast US
7990	Mediterranean Sea
8970	Great Lakes
8990	
9940	US West Coast
9960	Northeast US
9970	
9980	
9990	North Pacific

Map Datum and Fix Datum

The Map Datum is the geodetic datum to which position details are referenced on the chartplotter display. You can select a datum to match paper charts that you are using.

The Fix Datum is the geodetic datum to which position details received from the GPS are referenced. You should select the same datum as your GPS uses.

Position Correction

If the displayed position does not agree with your known position, and you cannot correct it by selecting the appropriate map datum or fix datum, you can apply a position correction. The value of the current correction is displayed on this menu.

- To apply a position correction:
 1. Move the selection bar to the Position Correction option and press **ENTER**. The chart is displayed.
 2. Use the trackpad to move the cursor until the correct position is displayed in the cursor readout box.
 3. Press the **DONE** soft key to set the correction, or press the **CLEAR** soft key to exit without change.

Setting Up the Chartplotter

The PLOTTER option from the Set Up menu allows you to set up your chartplotter display preferences.

The following table lists the Plotter parameters and their options, shows the factory default setting, and provides a space for you to make a note of your new default setting. Each parameter is described in the following subsections.

Parameter	Options	Factory Default	New Default
Waypoint Name	3 characters 6 characters 16 characters None	6 characters	
Waypoint Display	OFF ON	ON	
Course Vector	OFF SHORT LONG INFINITE	SHORT	
Heading Vector	OFF SHORT LONG INFINITE	SHORT	
Wind Vector	OFF ON	OFF	
Tide Vector	OFF ON	OFF	
Dead Reckoning	OFF ON	OFF	
Cursor Data Box	OFF ON	ON	

Waypoint Name

This option controls the number of characters of each waypoint name that are displayed on the chart. Reducing or removing the waypoint name can sometimes improve the readability of the chart.

Waypoint Display

This option controls whether or not the waypoints and events are displayed on the chart. If you set it to OFF, only the waypoints in the selected and active routes and the active waypoint (if any) are displayed.

Course Vector

When the Course Vector is switched on, your vessel is displayed on the chart with a line extending from the bow indicating the current course. You can select the length of the vector line; an “infinite” vector extends to the edge of the chart or to land.

The Course Vector is only displayed if you are tracking to a waypoint.

Heading Vector

When the Heading Vector is switched on, your vessel is displayed on the chart with a line extending from the bow indicating the current heading. You can select the length of the vector line; an “infinite” vector extends to the edge of the chart or to land.

Wind Vector

When the Wind Vector is switched on, your vessel is displayed on the chart with a line extending from it indicating the wind angle. The length of the line indicates the current wind speed.

The vector is only displayed if the required wind data is available from a wind instrument connected to your system.

Tide Vector

When the Tide Vector is switched on, your vessel is displayed on the chart with a line extending from it indicating the tide angle. The length of the line indicates the current tide speed.

The tide information is calculated from the speed through the water and the compass data, compared with position information from the GPS. It is therefore only displayed if all this information is available.

Dead Reckoning

If you set Dead Reckoning to ON, the chartplotter will calculate your position by dead reckoning if position data is lost. The dead reckoned position is calculated from your speed and heading (if available), and a dead reckoning indicator is shown at the top left of the display.

Set Dead Reckoning to OFF if you do not wish to use a calculated position.

Cursor Data Box

This option controls whether or not the cursor data box is displayed. If you turn it off, only the depth units and scale rule are displayed at the top left of the screen.

Setting Up the Alarms and Timers

You can set up the following navigational alarms and timers:

Parameter	Options	Factory Default	New Default
Arrival Radius Alarm	OFF Arrival radius value	OFF	
Off Course Alarm	OFF Value	OFF	
Anchor Alarm	OFF Value	OFF	
Danger Zone Alarm	OFF Value	OFF	
Countdown Timer	OFF ON (and value) RESET	OFF	
Elapsed Timer	OFF ON RESET	OFF	
Clock Alarm	OFF ON (and value)	OFF	

Alarms

All the alarms default to OFF. You can adjust the alarm settings to any value, in steps of 0.01. All the alarms relate to a specified distance.

Note: The alarm limits are not displayed on the chart.

When an alarm is set OFF, it is disabled. When an alarm is set to a value, it will be triggered when the alarm condition is met (see *Chapter 4*).

The alarms settings have the following functions:

- **Arrival alarm** specifies the radius of a circle around the waypoint: when your vessel reaches this circle the alarm sounds
- **Off course alarm** specifies the distance from the route, at right angles to the route, at which the alarm sounds
- **Anchor alarm** specifies the distance from the anchor position at which the alarm sounds; you can only set this if a position fix is available
- **Danger zone alarm** specifies the radius of a circle around marks classed as dangerous (see page 34): when your vessel reaches this circle the alarm sounds

Timers

The timer controls have the following functions:

- **Countdown timer** counts down from selected time (in hours, minutes and seconds); an alarm is triggered when the timer reaches zero
- **Elapsed timer** counts up from zero, and is displayed in the cursor data box on the chart
- **Clock alarm**, if set, sounds when the time data received by the system matches the time specified here (in hours, minutes and seconds); you can only select this if time data is being received

Fix Status

The FIX STATUS option allows you to access the GPS position fix status window that is displayed when you turn on the chartplotter.

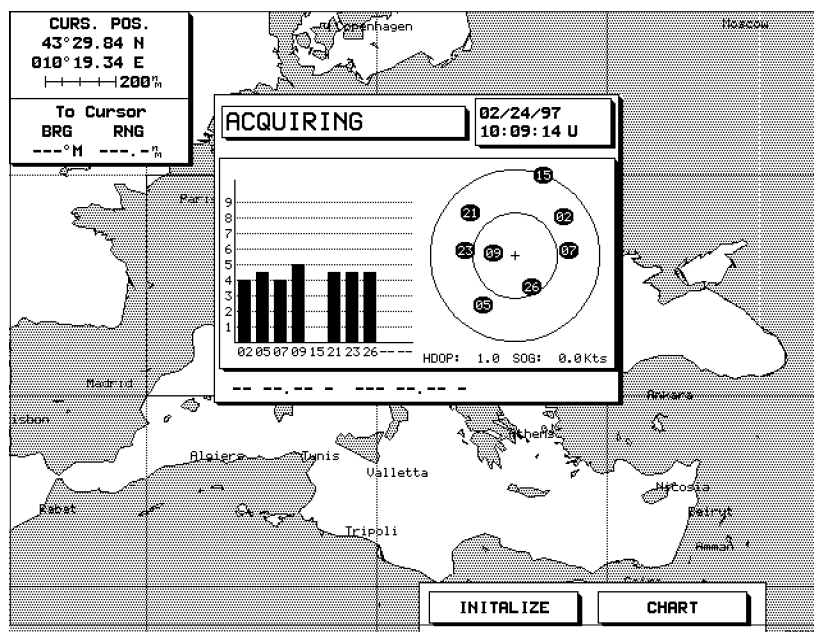

When a fix has been acquired, the text “Fix Good” is displayed at the top of the screen, and the vessel’s position at the bottom, together with the **HDOP** (precision) factor and the Speed Over Ground (SOG).

If required, you can initialize the GPS or perform manual setup of a differential beacon.

Initializing the GPS

- To initialize the GPS:
 1. Press the INITIALIZE soft key. The current date, time and position settings are shown.



2. Use the trackpad to edit the entries to the required values, and press **INITIALIZE** to send them to the position fixer.
3. Alternatively, press the **RESET** soft key to reset the GPS.
4. Press **CLEAR** or **ENTER** to return to the Fix Status screen, and **CHART** to return to the chart.

Setting Up a Differential Beacon

Normally, your differential beacon receiver (if fitted) automatically picks up the transmitted differential signal. If there are two differential beacons competing in a region, you may wish to set up the beacon manually.

- To set up a differential beacon manually:
 1. Press the **BEACON** soft key. The current settings, read from the beacon receiver (if connected) are displayed. ****PIC??****
 2. Use the trackpad to select the required bit rate, and to edit the beacon frequency to the required value.
 3. Press **ENTER** to accept the changes, or **CLEAR** to cancel.
 4. Press **CLEAR** or **ENTER** to return to the Fix Status screen, and **CHART** to return to the chart.

Memory C-Card

The **MEMORY C-CARD** option allows you to save or load data to or from a Memory C-Card. Data is saved or loaded in files, by type: a file can be used to store all waypoints, all marks, all tracks or an individual route.

- To save the data from the chartplotter's memory to a C-Card:
 1. Insert a Memory C-Card into one of the chart slots, in the same way as for a chart card (see Chapter 2).
 2. Press **MENU** to display the menus.
 3. Use the soft key or trackpad to highlight the **MEMORY C-CARD** option on the **SETUP** menu, and press **ENTER**.

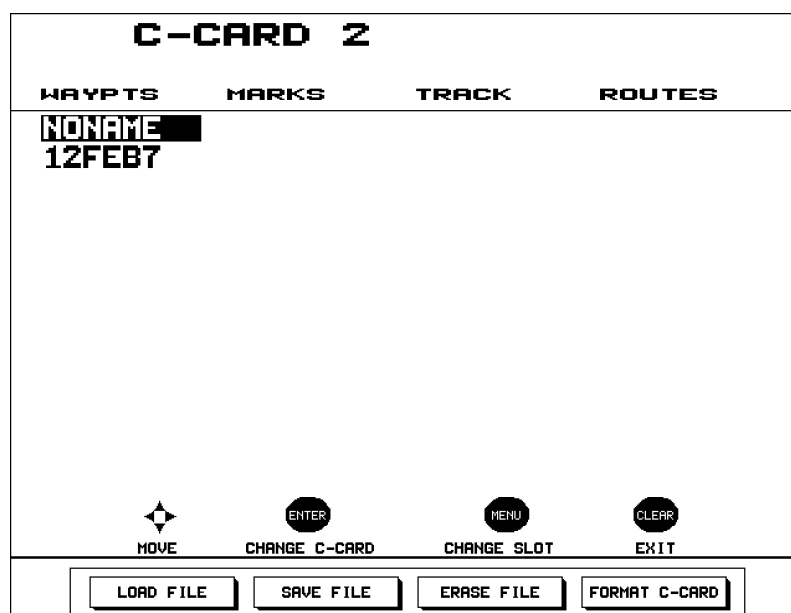

The list shows the names of the files, by type, stored on the current C-Card.

If the device is not available, press **MENU** to select the other slot for display.

4. Use the trackpad to select the type of data (Waypoints, Marks, Track or a Route) you wish to save.

Note: All data of the selected type is saved into the file, except for Routes where only the currently selected route is saved.

5. Press the **SAVE FILE** soft key.

The system prompts you for the name of the new file.

6. Change the default file name (NONAME) to the required name, using the trackpad left and right sides to select the character to change, and the up and down edges to change the character.
7. Press **ENTER** to accept the new name.

The system saves all the data of the selected type into the named file on the C-Card, and updates the display with the filename. If you have inserted a new (unformatted) c-card, the chartplotter automatically formats it before saving the file.

8. Press **CLEAR** to return to the chart display.

► To load data from a C-Card into the chartplotter's memory:

1. Insert the Memory C-Card into one of the chart slots and select the **MEMORY C-CARD** option, as described above.

If you already have the option selected, press **ENTER** to select a card change, insert the new card, and press **ENTER** again.

2. Use the trackpad to select the file you wish to load.
 3. Press the **LOAD FILE** soft key. The data is loaded into the chartplotter's memory.
 - Track or mark data replaces any existing data of the same type.
 - Waypoint data replaces any existing waypoints, and also deletes any existing routes.
 - The route from a route file is loaded as Route 0.
 4. Press **CLEAR** to return to the chart display.
- To erase data from a C-Card:
1. Display the file information for the card, as described above.
 2. Use the trackpad to select the file you wish to erase, and press the **ERASE FILE** soft key. Then press **ENTER** to confirm the deletion, or **CLEAR** to abandon the operation.

Alternatively, to remove all the data from the card, press **FORMAT C-CARD**. Then press **ENTER** to confirm the deletion, or **CLEAR** to abandon the operation.
 3. Press **CLEAR** to return to the chart display.

6.3 Customizing the Screen Display

You can customize the display of your chartplotter so that all the information you require is available at the touch of a button, and in the layout and detail you prefer.

You customize the display using the **SCREEN** menu, which is displayed when you press the **MENU** key. The **SCREEN** menu options control the following:

CARTOGRAPHY	Setting the cartographic detail
ORIENTATION	Setting the chart orientation
WINDOWS	Setting up the contents of the windows that can be displayed using the DISPLAY menus
COLORS	Setting up the colors used to display tracks, routes, symbols, vectors, the vessel and the cursor (available for color displays only)

Setting the Cartography Detail

The **CARTOGRAPHY** option allows you to select the types of cartographic features that will be displayed or hidden. You can also enable or disable Plotter Mode.

Note: Some cartographic details are automatically suppressed on small-scale charts, to avoid the chart appearing too cluttered.

- To set your preferred levels of cartographic detail:
 1. Press **MENU** to display the main menus.
 2. Use the trackpad or the **SCREEN** soft key to highlight the **CARTOGRAPHY** option from the **SCREEN** menu, and press **ENTER**. The Map Configuration main menu is displayed.
 3. Use the trackpad to move up or down the list and highlight the menu you require, then press **ENTER** to accept your selection. The menu options and their current settings are then displayed, as shown in the following table.
 4. Use the trackpad to move up or down the list and highlight the item you require, then press **ENTER** to accept your selection. The parameters for that option are then displayed.
 5. Use the trackpad to highlight the required setting, and press **ENTER**.
 6. Once you have reset all the required values, press **CLEAR** to return to the Map Configuration menu, and **CLEAR** again to return to the default display.

The following table lists the map configuration options and their default

settings, and provides a space for you to make a note of your new default setting. Items can be set either OFF or ON, unless indicated.

Menu/Parameters	Factory Default	New Default
Land Settings Menu		
Natural Features	ON	
Rivers & Lakes	ON	
Cultural Features	ON	
Landmarks	ON	
Marine Settings Menu		
Water Turbulence	ON	
Depths Contours	ON	
Depth Colour 1 Limit (value)		
Depth Colour 2 Limit (value)		
Depth Contours & Soundings		
Range (max & min values)	0-33ft	
Spot Soundings	ON	
Bottom Type	ON	
Nav-Aids and Features		
Ports & Services	ON	
Attention Areas	OFF	
Tracks & Routes	ON	
Lights	ON	
Buoys & Beacons	ON	
Signals	ON	
Cartographic Objects	ON	
Other Settings Menu		
Names	ON	
Compass	ON	
Chart Generation	ON	
New Objects	ON	
Simplified Display	ON	
Info Level (Basic or Detailed)	DETAILED	
Chart Settings Menu		
Lat/Lon Grid	ON	
Chart Boundaries	ON	
Plotter Mode	OFF	

Chart Orientation

You can select the normal orientation of your chart according to your personal preference. The orientation can be one of the following:

- **North Up:** The chart is displayed with north upwards. This is the standard chart mode.
- **Course Up:** The chart is displayed with the currently selected course leg upwards. If you change course, the chart will rotate to keep the course upwards.

- **Head Up:** The chart is displayed with the vessel's current heading upwards. This is useful if you wish to compare the chart with a radar screen.

As the heading changes the chart will rotate, although some damping is provided to stop it swinging too wildly. You can set the amount of damping by adjusting the Head Up Response parameter in the system set up (see page 62).

When you first select Head Up Mode, or if you select Home Mode when in Head Up Mode, the cursor is homed on the vessel and the chartplotter display is in **Relative Motion** mode. In this mode, the chart moves to keep the vessel in the centre of the display. When you move the cursor away from the vessel, the display returns to normal **True Motion**, and the vessel moves across the chart.

Note: When the chart rotates in Course Up or Head Up mode, it may not be possible to display the chart text. In this case, markers are left at the text points which you can interrogate using the cursor (see Section 3.2).

- To select the orientation:
 1. Press **MENU** to display the main menus.
 2. Use the trackpad or the **SCREEN** soft key to highlight the **ORIENTATION** option from the **SCREEN** menu, and press **ENTER**. The soft key labels change, as follows:

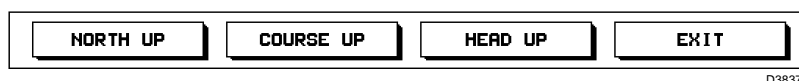

D3837-1

3. Press the soft key corresponding to the chart orientation you require. The new chart orientation is displayed.
4. Press the **EXIT** soft key to clear the soft key labels.
The display reverts to the default soft keys display, with the new chart orientation.

Setting Up Windows

The chartplotter includes 6 default sets of data that can be displayed using the **DISPLAY** key options, as described in Chapter 4. These options allow you to select the data set to be displayed in either one or two windows, with a choice of window positions.

A powerful feature of the chartplotter is the ability to define your own windows so that, when you request a windowed display, precisely the data you require is displayed alongside the chart. You can define up to 4 customized windows, in addition to the 6 default windows.

► To set up a customized window:

1. Press **MENU** to display the main menus.
2. Use the trackpad or the **SCREEN** soft key to highlight the **WINDOWS** option from the **SCREEN** menu, and press **ENTER**.

The Customize On Screen Data Windows screen is displayed, showing the last-used window selection. An example screen is shown below.

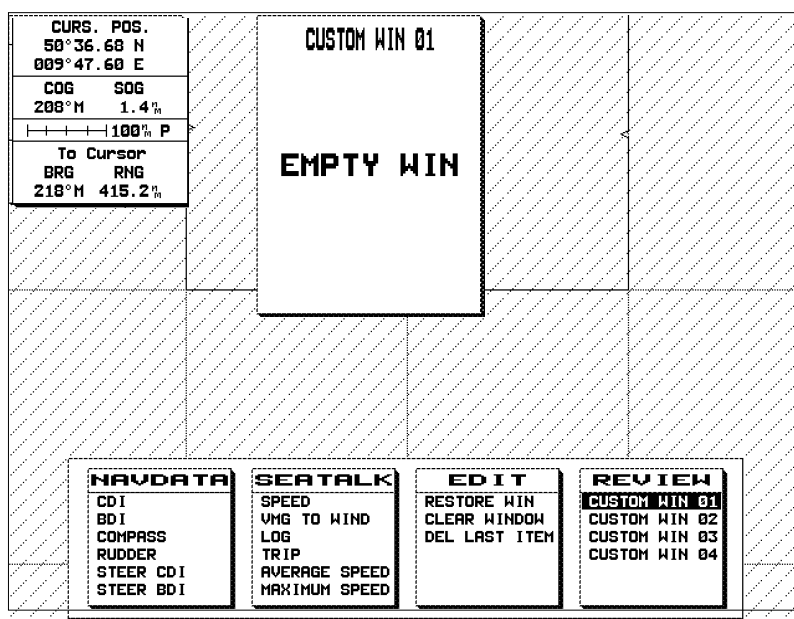

3. If the custom window you wish to set up or change is not already displayed, use the **REVIEW** soft key to display the required window.

Now you are ready to start specifying the data that will be displayed. The **NAVDATA** and **SEATALK** menus list all the data that is available for selection: further options can be seen by scrolling down the menus using the trackpad or soft keys.

4. Highlight one of the data options in either the **NAVDATA** or **SEATALK** menu, and press **ENTER**.

The data appears in the window at the top of the screen. Some items, such as **CDI**, fill the entire window. Most of the **SeaTalk** items take up one line, but some (such as the **FULL WAYPOINT** selection) take up 2 lines.

5. If you make a mistake or change your mind, you can delete the last item using the **DELETE LAST ITEM** option from the **EDIT** menu.

Alternatively, you can clear all the items in the window using the **CLEAR WINDOW** option. **RESTORE WIN** will restore a cleared window that has been saved.

6. Repeat step 4 until you have selected all the data options you require.

7. If you wish to set up another window, use the **REVIEW** soft key to select another window and repeat the procedure.
8. When you have finished defining windows, press **CLEAR** to return to normal operation.
9. You can now check the appearance of your windows using the **DISPLAY** key (see Section 4.4).

Changing Color Settings

The color chartplotter includes options for setting the colors of the following:

- Tracks
- Routes
- Symbols (waypoints, marks and events)
- The vessel
- Vectors
- The cursor

Note: You cannot change the colors of the charts and their associated objects.

► To change the color settings:

1. Press **MENU** to display the main menus.
2. Use the trackpad or the **SCREEN** soft key to highlight the **COLORS** option from the **SCREEN** menu, and press **ENTER**. The following window is displayed:

NEED SCREEN CAPTURE OR DRAWING



3. Use the up and down trackpad controls to select an item type to change. Where necessary, press the appropriate soft key to select the specific item (TRACK, ROUTE, SYMBOL, VECTOR) to change.
4. Press **ENTER** to accept your selection. The available colours are displayed, use the up and down trackpad controls to select a colour then press **ENTER** to accept the colour (or **CLEAR** to cancel the selection).
5. Once you have reset all the required values, press **CLEAR** to return to the Screen Setup menu, and **CLEAR** again to return to the default display.

Note: *You can set all the colors back to their factory defaults. To do so, highlight the **FACTORY DEFAULTS** option, press **ENTER** to confirm that you wish to reset the colors.*

Chapter 7: Installation

7.1 Introduction

This chapter explains how to install the chartplotter.

The chartplotter can be trunnion (yoke) or panel mounted. It must be connected to a power supply and to a source of position data, and can also be connected to other units via the SeaTalk or NMEA connections.

You can install more than one chartplotter as part of a larger system. Details of the current route or GO TO are sent to the second unit.

An example of an integrated system is shown in the following diagram.

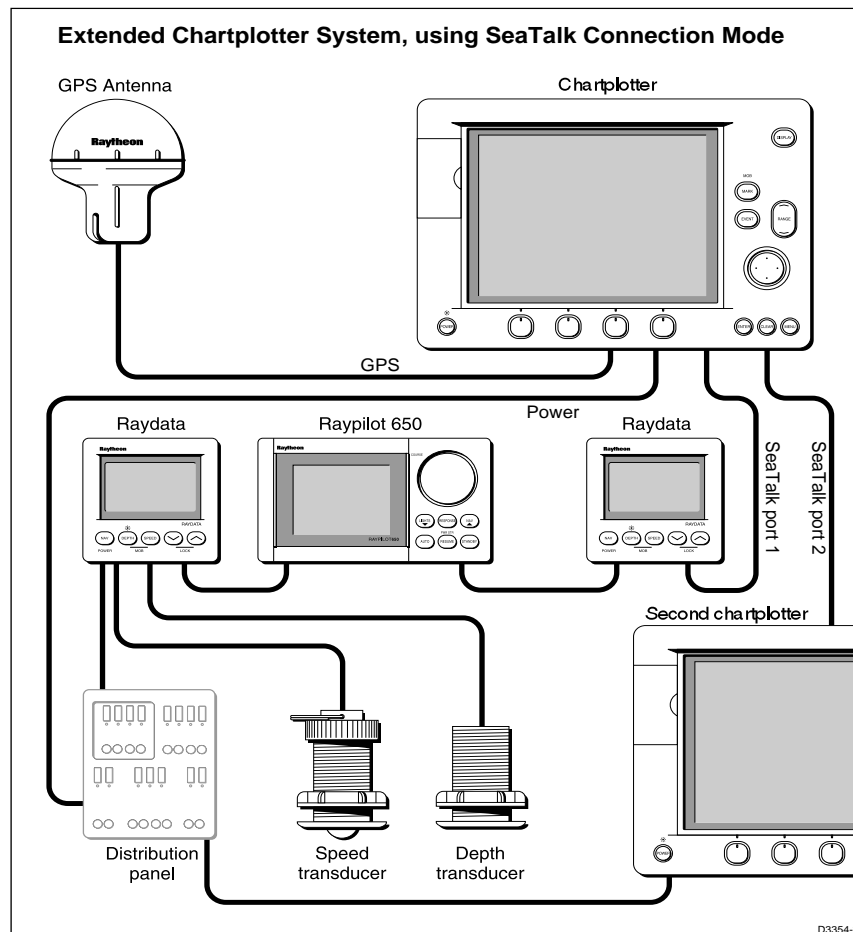

Note: Before attempting any installation, you should read the Electromagnetic Compatibility (EMC) installation guidelines provided in Section 7.3.



This chapter covers the following topics:

- Packing list
- Planning the installation
- Mounting the chartplotter
- Chartplotter connections
- System check and initial setup

If you are connecting your chartplotter to a larger system, you should refer to the installation instructions for the other units and for connection to the SeaTalk bus.

EMC Installation Guidelines

All Raytheon equipment and accessories are designed to the best industry standards for use in the leisure marine environment.

Their design and manufacture conforms to the appropriate Electromagnetic Compatibility (EMC) standards, but correct installation is essential to ensure that EMC performance is maintained. Although every effort has been taken to ensure that they will perform under all conditions, it is important to understand what factors could affect the operation of the product.

To avoid the risk of operating problems, all Raytheon equipment and cables connected to it should be:

- At least 3 feet (1m) from any equipment transmitting or cables carrying radio signals e.g. VHF radios, cables and antennas. In the case of SSB radios, the distance should be increased to 7ft (2m).
- More than 7ft (2m) from the path of a radar beam. A radar beam can normally be assumed to spread 20 degrees above and below the radiating element.
- The equipment should be supplied from a different battery than the one used for engine start. Voltage drops below 10v in the power supply to our products can cause the equipment to reset. This will not damage the equipment, but will cause the loss of some information and can change the operating mode.
- Genuine Raytheon cables should be used at all times. Cutting and rejoining these cables can compromise EMC performance and so should be avoided unless doing so is detailed in this handbook.
- If a suppression ferrite is attached to a cable, this ferrite should not be removed. If the ferrite has to be removed during installation it must be reassembled in the same position.

The following illustration shows the range of suppression ferrites fitted to Raytheon equipment.

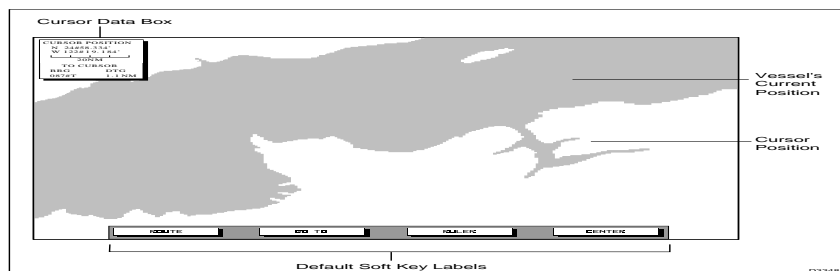

If your Raytheon equipment is going to be connected to other equipment using a cable not supplied by Raytheon, a suppression ferrite **MUST** always be fitted to the cable close to the Raytheon unit.

7.2 Packing List

Your chartplotter display (part number M93536) should be supplied with the following:

- Trunnion (yoke) bracket, fitted to the display with two knobs
- Self-tapping screws (4) for fixing trunnion bracket
- Power cable
- SeaTalk cable
- Sun cover
- Panel mounting kit, consisting of a gasket, thumb studs (4), thumb nuts (4), and fixing template
- This handbook
- Quick reference card

If you have purchased the ChartPlotter GPS System (part number M93550), the package will also include the Raytheon Raystar 112 GPS.

7.3 Planning the Installation

Before starting the installation, you need to select a suitable location and mounting method for the chartplotter, and consider the connection options and cabling requirements.

Selecting a Location

The chartplotter can be mounted in two ways:

- Attached to a bulkhead, using the trunnion bracket already fitted to the display
- On a panel (tabletop or console), using the mounting kit provided

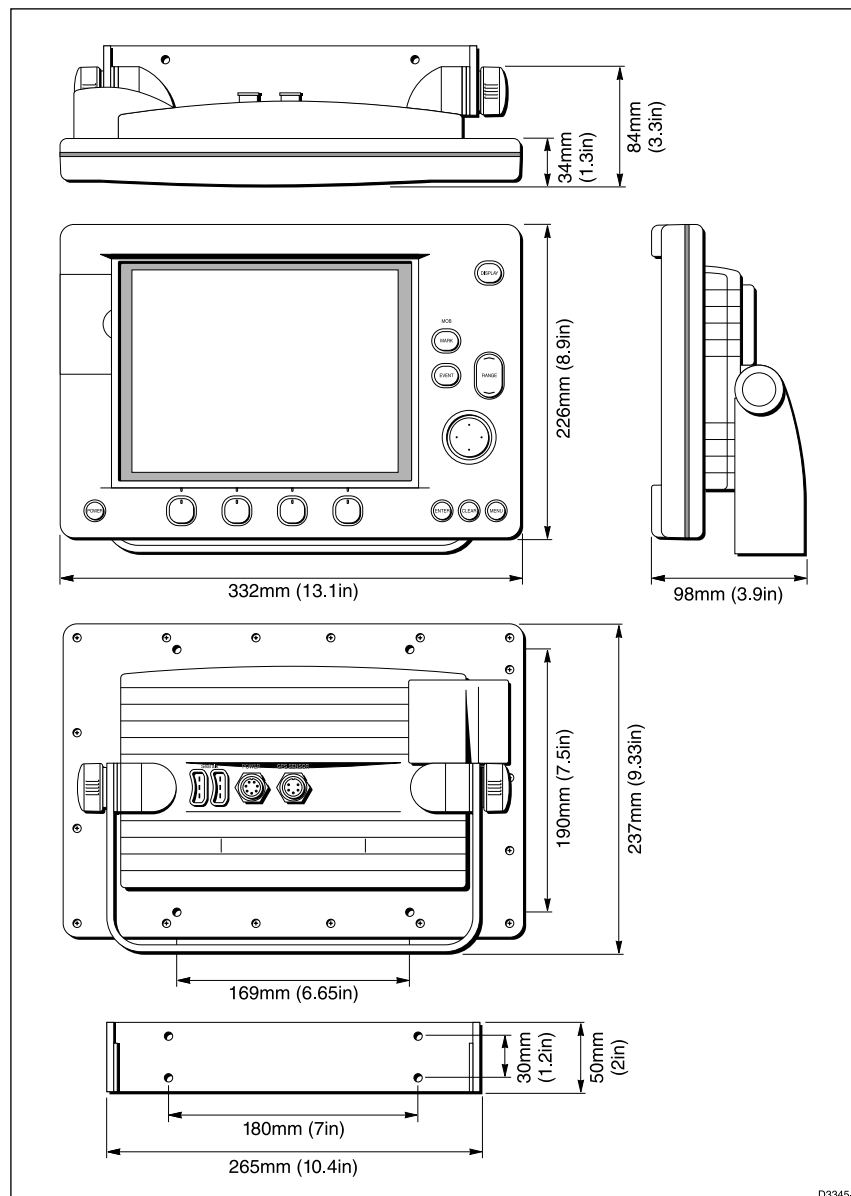

Although the chartplotter is designed to meet the CFR46 waterproofing standard, it is advisable to mount it, whenever possible, so that it is not exposed to the direct effects of salt spray or the hot sun.

The monochrome chartplotter is provided with a sun cover. It is designed for above or below deck installation. The colour chartplotter is designed only for below deck installation. When installing the chartplotter ensure it is:

- Easily read by the helmsman
- Protected against physical damage
- At least 230mm (9in) from a compass
- At least 1m (3ft) from radio receiving equipment
- Accessible from behind for ease of installation and cable running

Note: LCD displays have a specific viewing angle for optimum visibility, which is normally within 30° of head-on viewing. You may wish to apply power to the chartplotter and view the display in various locations before mounting the unit permanently.

Connection Options

The chartplotter can communicate with other instruments using any of the following data standards:

- **SeaTalk**, using the dedicated SeaTalk input/output ports.
Navigation data can be received from the dedicated GPS port, the Power/NMEA In port or from the SeaTalk port. If data is available on both, then data from the SeaTalk port will have priority.
All SeaTalk sentences are decoded, and can be selected for display via data windows (see Section 6.3). All SeaTalk data is available as output.
- **GPS NAVAID**, using the GPS Sensor port . You should use this option if you are connecting a RayStar 112 GPS and also require NMEA output. You can set up your system so that NAVAID data has priority over NMEA data.
- **NMEA**, using the Power/NMEA In port. You can set up your system so that NMEA data has priority over NAVAID data.

A printer can also be connected on the NMEA port

Cabling

Plan your cable runs before you start the installation. Consider the following points:

- All cables should be adequately cleated and protected from physical damage and exposure to heat
- Acute bends must be avoided
- Where a cable passes through an exposed bulkhead or deckhead, a watertight gland or “swan neck” tube should be provided

7.4 Mounting the Chartplotter

The chartplotter can be mounted using the trunnion (yoke) bracket already fitted, or panel mounted using the supplied mounting kit.

Trunnion Mounting

- To mount the chartplotter using the trunnion bracket:
 1. Loosen the trunnion knobs on each side of the chartplotter, and remove the trunnion from the unit.
 2. Mark the locations of the trunnion screw holes on the mounting surface.
 3. Use the screws supplied to fix the trunnion at the marked locations.
 4. Fit the chartplotter to the trunnion, adjust the display angle and tighten the knobs.

Panel Mounting

- To mount the chartplotter on a panel or console (as shown in the illustration on the following page):

1. Select a clear location at least 350mm (13¾ in) by 250mm (9¾ in).

CAUTION:

Make sure there are no hidden electrical wires or other items behind the desired location before proceeding.

Check that you have free access for mounting and cabling. You will require access at the back of the chartplotter to tighten the thumb nuts.

2. Unpack the panel-mounting kit.
3. Using the supplied template, trace out the appropriate screw hole locations for panel mounting, and the display unit opening.
4. Drill a 12.7mm (½ in) pilot hole in each opposing corner of the cut-out area.
5. Using a suitable saw, cut along the outside edge of the cut-out line.

6. Remove the trunnion (yoke) knobs and bracket from the chartplotter. Make sure that the unit fits in the cut-out area.
7. Drill four 5mm ($1/5$ in) holes in the marked locations.
8. Complete the installation of the power data cabling, GPS input, and any other accessory cables to the console (see Section 7.5).

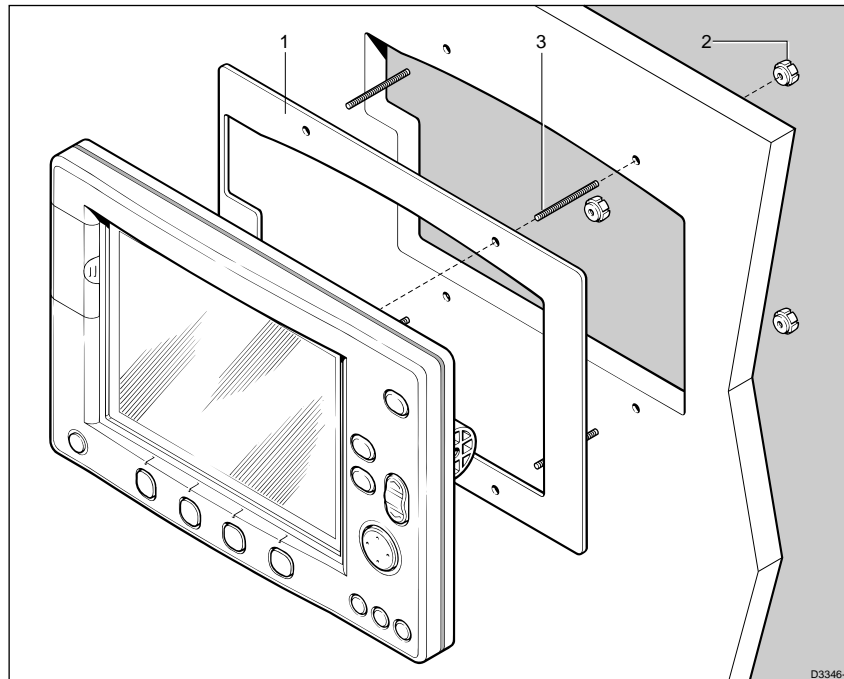

1 Gasket **2** Thumb nuts (4 off) **3** Thumb studs (4 off)

9. Slide the unit into the panel cut-out. A suitable sealant may be used between the gasket (1) and panel to prevent moisture entering the panel.
10. Fix the chartplotter to the panel using the four thumb studs and four thumb nuts supplied.

7.5 Chartplotter Connections

The chartplotter has 4 rear panel connectors, as follows:

1. SeaTalk input and output: two 3 pin flat connectors, each providing data input and output
2. Power and input/output (NMEA and printer): 7 pin male connector
3. GPS Sensor input: 5 pin male connector, **for a Raytheon GPS only**

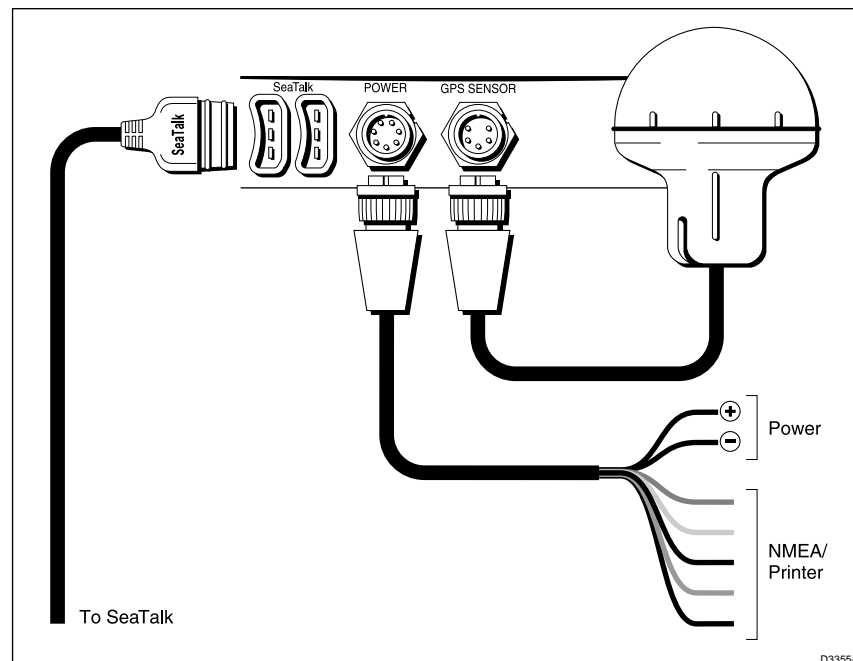

Power and I/O Connection

The DC power, NMEA (navaid) input/output and/or printer output should be connected at the rear Power/NMEA J5 seven-pin connector, as shown above. The pin functions are listed in the table below.

Pin No.	Function	Colour
1	Battery positive (10.7 - 32 VDC)	Red
2	Battery negative	Black
3	NMEA data input (+ve)	White
4	NMEA input (-ve) - common	Green
5	Printer ready	Grey
6	NMEA data out OR printer out	Yellow

7	Data output common	Brown
	Ground	Screen

DC Power

The chartplotter is intended for use on ships' DC power systems operating in the 10 to 35V DC range.

The connections should be made at a power distribution panel, isolation switch or to the battery (but not preferred). Check that all connections are clean.

- Connect the power supply using the standard power cable supplied, as follows:
 1. Connect the moulded power plug to the power connection on the rear of the chartplotter. Run the free end back to the vessel's distribution panel.
 2. Cut the cable to length and connect the red wire to 12V (+ve battery terminal) and the black wire to 0V (-ve battery terminal). Protect the circuit with a 5A fuse/circuit breaker.
 3. Cut any unused cores short, or use a suitable junction box to connect to NMEA equipment and/or a printer.
 4. Connect the screen to the ship's ground.

Note: If the power connections are accidentally reversed the system will not work. Make sure that the input power leads are connected for correct polarity, using a volt meter.

NMEA Connection

You can use this port to interface the chartplotter with other equipment capable or receiving/transmitting data to the NMEA 0183 standard (see Appendix A).

Printer Connection

If you connect a printer to your chartplotter, you can print any display, including charts, routes and waypoint details. The chartplotter supports baud rates in the range 300 to 9600.

Refer to your printer manual for connection and setup information.

Note: The printer is connected to the NMEA port. If the printer is switched ON, but you have not selected a print function, NMEA data will be printed. When you select a print function, the required data will be printed.

GPS Connection

You can connect your GPS via any of the chartplotter connectors (SeaTalk, GPS or Power/NMEA), depending on how you have decided to set up your system (see Section 7.3).

If you are connecting the RayStar 112 GPS to your chartplotter, use the connection cable provided.

The GPS port's pin functions, referenced to the GPS, are listed in the table below.

Pin No.	GPS Function	Colour
1	+12V DC	Red
2	0V DC	Black
3	Ground I/O	White
4	GPS out	Yellow
5	GPS in	Green
6	Not used (differential)	Brown

SeaTalk Connection

The chartplotter can be connected to an existing SeaTalk system, using the supplied SeaTalk cable connected to a SeaTalk connector on the rear of the chartplotter. The data is passed from instrument to instrument via the daisy loom cable.

Note: The SeaTalk connector cannot be used to power the chartplotter. Power from the chartplotter cannot be used to supply power to other SeaTalk equipment.

7.6 System Check and Initial Setup

Once you have installed your chartplotter and made all the connections, you need to check and test your installation before using the system for navigation.

You may wish to read Chapters 2 to 6, and familiarize yourself with the operation of the chartplotter, before performing the initial setup.

System Check

Before performing the power-on test, check the following:

- All securing screws are fully tightened
- All connections have been made
- All connecting wires are secured and protected as necessary

Note: If you are the boat owner and have performed the installation yourself, you should ask your dealer to check the installation before going to sea.

Switch On and Initial Setup

1. Press the **POWER** key to switch on the display unit.
2. Press the **CONTINUE** soft key to clear the navigation notice.
3. Press the **CHART** soft key to clear the Fix Status screen, and any key to clear the alarm message.
4. If you have other equipment connected via the NMEA and NAVAIDS ports, set the priority as follows:
 - a. Press **MENU** to display the menu options, use the trackpad or right-most soft key to highlight the **SYSTEM** option on the **SET UP** menu, and press **ENTER**.
 - b. Use the trackpad to highlight the **GPS Input** selection option, press **ENTER** to list the options, highlight the required option and press **ENTER** again
 - c. Press **CLEAR** to return to the chart.
5. If you are using a Loran device and wish to use Loran TDs instead of latitude and longitude, select the **NAVIGATE** options from the **SET UP** menu. Select **TD** from the **Position Resolution** options, and also set up your TD information on the **TD Settings Menu**.



6. To speed up your initial position fix, select the **FIX STATUS** option from the **SET UP** menu, press the **INITIALIZE** soft key, and use the trackpad to edit the position data to match your current position. Refer to section 6.2 for further information.

You can perform additional customization, as described in Chapter 6.

EMC Checks Before Going to Sea

Always check the installation before going to sea to make sure that it is not affected by radio transmissions, engine starting etc..

In some installations, it may not be possible to prevent the equipment from being affected by external influences. In general this will not damage the equipment but can lead to it resetting, or momentarily may result in faulty operation.



Chapter 8: Maintenance and Problem Solving

This chapter provides information on routine maintenance and on possible causes of problems you may experience with your chartplotter.

8.1 Routine Maintenance

The chartplotter is a sealed unit. Maintenance procedures are therefore limited to cleaning and periodical checks.

Note: Never use chemical or abrasive materials to clean the chartplotter. If the unit is dirty, wipe it with a clean, damp cloth.

Cabling and Connections

Periodically check the cabling for chafing or damage to the outer casing, and replace any damaged cables.

Make sure that the connections to the vessel's DC power are clean and tight.

EMC Servicing and Safety Guidelines

This chartplotter unit contains no user serviceable parts. Raytheon equipment should be serviced only by authorized Raytheon service engineers. They will ensure that service procedures and replacement parts used will not affect performance. There are no user serviceable parts in any Raytheon product.

Some products generate high voltages, and so never handle the cables/connectors when power is being supplied to the equipment.

Always report any EMC related problem to your nearest Raytheon dealer. We will use any such information to improve our quality standards.

8.2 Unit Test and Reset

The chartplotter includes a Unit Test menu that allows you to test various aspects of the unit and to reset the memory.

Note: If you plan to reset your system, you may wish to copy any stored data to a Memory C-Card first, since all stored data in the chartplotter is cleared by the memory reset.

► To use the Unit Test options:

1. Power off the chartplotter
2. Press and hold a soft key, then press **POWER** to power on the chartplotter.

The menu has the following options:

FULL TEST	Tests all the other items in the menu.
VIDEO	Displays the grey scales in bands.
RAM	Checks the RAM (memory), and provides a Clear option (see below).
DIM MENU	Allows you to adjust the brightness and contrast.
KEYBOARD	Displays a diagram of the chartplotter, and confirms each key's correct operation by updating the key display on the diagram.
CARTRIDGES	Reports the current charts found, and provides a cartridge connector test.
CONNECTORS	Reports the current connections found (Printer, SeaTalk, NMEA and GPS), and provides tests.
SERIAL PORTS	Provides port selection, setup and test options.

3. Use the trackpad to highlight the required option, and press **ENTER**.
4. To return to the menu, press **MENU**.
5. To return to normal operation, press and hold the **POWER** key for 3 seconds to turn off the chartplotter, then press **POWER** to turn it on again.

► To clear the memory:

1. Highlight the RAM option and press **ENTER**.
2. Press
3. Press **MENU** to return to the Unit Test menu.

8.3 Problem Solving

All Raytheon products are, prior to packing and shipping, subjected to comprehensive test and quality assurance programmes. However, if this unit should develop a fault, please refer to the following table to identify the most likely cause and the corrective action required to restore normal operation.

If you still have a problem after referring to the following table, contact your local dealer, national distributor or Raytheon Product Support Department for further advice.

Always quote the product serial number. This number is printed on the rear of the chartplotter, below the connectors.

Common Problems and Their Solutions

Problem	Correction
No power input.	<ol style="list-style-type: none"> 1. Make sure that the power supply cable is sound and that all connections are tight and free from corrosion. 2. Check polarity of the DC power cables for proper connection. Reconnect leads if necessary. 3. Check in-line fuse. Replace if necessary. 4. Check vessel's power (battery) for correct voltage readings (10-35V DC).
Poor chart definition.	Adjust contrast setting and/or backlight level.
No position information.	<ul style="list-style-type: none"> Check the GPS/Loran connection. Check the GPS/Loran receiver/antenna. Check your estimated latitude and longitude. Check the time and date, and correct if necessary.
No SeaTalk data received.	Check the SeaTalk connector and the SeaTalk network.
No NMEA data received.	Check the NMEA connector and the NMEA equipment.

If you still have a problem after referring to the table above, refer to Section 8.3 for information on testing the unit and clearing the memory.

If this does not resolve the problem, contact your local dealer or Raytheon Product Support Department for further advice.

How to Contact Raytheon (US)

For Marine Product and Services Information

Visit the Raytheon World Wide Web site for the latest information on the newest Raytheon Marine electronic equipment and systems at:

www.raymarine.com

For Accessories and Parts

Many Raytheon accessory items and parts can be obtained directly from your authorized Raytheon dealer. However, if you are in need of an item not available from the retailer, please contact Raytheon Customer Service at 1-800-539-5539 extension 2333 or (603) 647 7530 extension 2333. Customer Service is available Monday through Friday 8:15 AM to 5:00 PM Eastern Standard Time.

Please have the Raytheon item or part number ready when calling if placing an order (See the Optional Accessory List in this manual on page 2). If you are not sure which item is appropriate for your unit, you should first contact the Technical Support Department at 1-800-539-5539 ext. 2065 to verify your requirements.

For Technical Support:

For technical support, call 1-800-539-5539 extension 2444 or (603) 647-7530 extension 2444. The Raytheon Fax number is 1-603-634-4756.

Our Technical Support Specialists are available to answer questions about installing, operating and trouble-shooting all Raytheon products. Questions may be addressed directly to our Technical Support Department via the Internet at:

rmc_tech_raytheon@raymarine.com.

For Product Repair and Service

In the unlikely event your Raytheon unit should develop a problem, please contact your authorized Raytheon dealer for assistance. The dealer is best equipped to handle your service requirements and can offer timesaving help in getting the equipment back into normal operation.

In the event that repairs can not be obtained conveniently, product service may also be obtained by returning the unit to Raytheon's Product Repair Center using the prepaid UPS shipping tag supplied with your unit to:

Raytheon Product Repair Center
676 Island Pond Road
Manchester, NH 03109-5420

The Product Repair Center is open Monday through Friday 8:15 a.m. to 5:00 p.m. Eastern Standard Time or Eastern Daylight Savings Time. All products returned to the Repair Center are registered upon receipt. A confirmation letter will be sent to you acknowledging the repair status and the product's reference number. Should you wish to inquire about the repair status of your unit, contact the Product Repair Center at 1-800-539-5539 extension 2118. Please have the product reference number, or unit serial number, ready when you call. We will do everything possible to make the repair and return your unit as quickly as possible.

How to Contact Raytheon (Europe)

In Europe, Raytheon support, service and accessories may be obtained from you authorised dealer, or contact:

Raytheon Marine Company
Anchorage Park, Portsmouth
PO3 5TD, England
Tel (01705) 693611
Fax (01705) 694642

Our technical support staff may also be reached via the Internet. Questions may be addressed directly to:

techsupra@raytheon.com.

Or visit the Raytheon Electronics World Wide Web site:

www.raymarine.com

Technical Support

The Customer Services Department handles enquiries concerning installation, operation, fault diagnosis and repair. Please refer to the lists of component part numbers and optional accessories in the Installation chapter of this manual, and have the Raytheon part number ready when speaking with your dealer.

Accessories and Parts

Many Raytheon accessory items and parts are available through your authorised Raytheon dealer.

If you are uncertain about what item to choose for your Raytheon unit, please contact our Customer Services Department prior to placing your order.

Worldwide Support

Please contact the authorised distributor in the country. A list of worldwide distributors is supplied with your system.



Appendix A: Specification

This appendix provides the physical and electrical specification for the chartplotter.

Approvals:		
CE		
FCC		
Size	22.6 x 33.2 x 6.0 cm (8.9" x 13" x 2.4"), excluding trunnion	
Weight	1.55 Kg (55 oz)	
Environmental:		
	Waterproofing:	To CFR46; suitable for external mounting
	Temperature Range:	
	Humidity:	
Mounting	Trunnion (yoke) or panel	
Power		
	Input:	External 10 -35 volts DC required
	Consumption:	Less than 6W internal - monochrome Less than 20 W internal - color
Controls	8 defined keys, 4 soft keys and trackpad	
Display type	640 x 480 VGA quality LCD either: monochrome with 4 grey scales or: color	
Display size	10" diagonal (19 x 14.5 cm) - monochrome 10.4" diagonal () - color	
Interfaces	SeaTalk receive and transmit NMEA 0183 receive and transmit Printer	
Position data	GPS, dGPS or Loran-C	
Cartography	C-MAP NT C-Cards	
Software update	Via C-Card	
Memory		
	Capacity:	Waypoints/events: 1000 (20 routes of 50 waypoints) Marks/danger zones: 1000 Track histories: 5,000 points, 5 files
	Protection:	Built in Lithium battery giving 3 to 5 years storage
	External:	C-MAP Memory C-Cards for data storage/retrieval



Glossary

This glossary explains the terms and abbreviations that may be unfamiliar to the reader.

G.1 Terms

Bearing	The direction of an object from the observer. Can be stated as an angle relative to either true or magnetic North.
Course	The direction in which the vessel is to be steered or is being steered. The direction of travel through the water. Can be stated as °Magnetic or °True.
Dedicated key	A key with a permanently defined function or functions. These keys are labelled on the front panel of the chartplotter.
Heading	The direction in which the vessel is pointing.
Home Mode	The mode in which the cursor is hidden, and the cursor data box gives the vessel's position and the range and bearing to the active waypoint (if any).
Latitude	Angular measure 0 to 90° North and South from the equator. On a chart, these lines are drawn from right to left.
Longitude	Angular measure 0 to 180° East and West of the prime meridian (0°) at Greenwich, England. On a chart, these lines are drawn from top to bottom.
Orientation	The chart orientation, which can be head up, course up or north up.
Panning	Moving the "window" on the displayed chart to bring a new area into view.
Plotter Mode	The mode in which, when no cartographic information is available at the current range, only a lat/long grid is displayed. If it is switched off in setup (the default setting), only ranges for which cartographic information is available can be selected.
Relative Motion	The mode in which the chart moves to keep the vessel's location in the centre of the display.
Route	A sequence a waypoints.
SeaTalk	The Raytheon standard for data communications.
Soft key	A key without a printed label, whose function depends on the context in which it is used. The current function is indicated by a label on the screen immediately above the soft key.



Time out	The automatic clearing of a message or the soft key labels after 7 seconds.
True Motion	The mode in which the chart remains fixed and the vessel moves across the display. This is the normal display mode.
Variation	The difference in degrees between “True North” and “Magnetic North”.
Waypoint	Any location that has been stored in memory with Lat/ Long or TD as the coordinates, which is to be used as a destination or a turning point on the route to the destination.
Window	A boxed area inset on the main screen, containing information.



G.2 Abbreviations

BDI	Bearing Deviation Indicator
BTW	Bearing To Waypoint
CDI	Course Deviation Indicator
CMG	Course Made Good
COG	Course Over Ground. The actual direction of your vessel's calculated movement over the ground.
dGPS	Differential Global Positioning System
DMG	Distance Made Good
DTG	Distance To Go
EMC	Electro-Magnetic Compatibility
ETA	Estimated Time of Arrival
GPS	Global Positioning System
HDOP	Horizontal Dilution Of Precision. The multiplicative factor that modifies ranging error. It is caused solely by the geometry between your vessel and your set of satellites.
MOB	Man OverBoard
NMEA	National Marine Electronics Association (interconnection standard)
SOG	Speed Over Ground. A calculation of the rate of movement of the vessel over the ground.
TD	Time Difference. The difference in time of arrival (measured in microseconds) of the two Loran signals, one from the master transmitting station and the other from the secondary.
TTG	Time To Go
VMG	Velocity Made Good. The component towards your destination based on your vessel's current speed.
WPT	Waypoint
XTE	Cross Track Error

