

Distributed by
Raymarine

Any reference to Raytheon or RTN in this manual should be interpreted as Raymarine. The names Raytheon and RTN are owned by the Raytheon Company.

Combined GPS & Differential Beacon Receiver Installation Guide

Document number: 81151_2
Date: 20th May 1999

IMPORTANT NOTICE

This device is only an aid to navigation. Its accuracy can be affected by many factors, including equipment failure or defects, environmental conditions and improper handling or use.

It is the user's responsibility to exercise common prudence and navigational judgement, and this device should not be relied upon as a substitute for such prudence and judgement.

1. EMC Installation & Service Guidelines

All Raytheon equipment and accessories are designed to the best industry standards for use in the leisure marine environment.

Their design and manufacture conforms to the appropriate Electromagnetic Compatibility (EMC) standards, but correct installation is essential to maintain EMC performance and CE compliance. Although every effort has been taken to ensure that they will perform under all conditions, it is important to understand what factors could affect the operation of the product.

Installation

All Raytheon equipment and cables connected to it should be;

- At least 1m (3ft) from any equipment transmitting or cables carrying radio signals eg. VHF radios, cables and antennas. In the case of SSB radios, the distance should be increased to 2m (7ft).
- More than 2m (7ft) from the path of a radar beam.
- The equipment should be supplied from a different battery than the one used for engine start. Voltage drops below 10.7V in the power supply to our products can cause the equipment to reset. This will not damage the equipment, but may cause the loss of some information and can change the operating mode.
- Genuine Raytheon cables should be used at all times. Cutting and rejoining these cables can compromise EMC performance and so should be avoided unless doing so is detailed in the installation manual.

Check Before Going to Sea

- Always check the installation before going to sea to make sure that it is not affected by radio transmissions, engine starting etc.
- In some installations, it may not be possible to prevent the equipment from being affected by external influences. In general this will not damage the equipment but can lead to it resetting, or momentarily may result in faulty operation.

Servicing and Safety

- This product contains no user serviceable parts.
- Raytheon equipment should be serviced only by authorised Raytheon service engineers. They will ensure that service procedures and replacement parts used will not affect performance. There are no user serviceable parts in any Raytheon product.
- Always report any EMC related problem to your nearest Raytheon dealer. We will use any such information to improve our quality standards.

2. Package Contents

Checking your Raystar 114 Package

The Raystar 114 Combined GPS and Differential Beacon Receiver package contains the following standard items:

1. Raystar 114
2. Beacon Aerial
3. Rail/Surface Mount Bracket, eyelit and screws
4. Installation Guide including Warranty document

Items Missing?

If any of the above items are missing or damaged, please contact your Raytheon dealer or our Product Support Department to obtain replacement parts. **Please note that missing or damaged items cannot be replaced without proof of purchase.**

Registering this Product

Once you have checked that you have all of the listed components, please take the time to complete the warranty document and return it to your national distributor.

By returning this document you will receive prompt and expert attention should you ever experience any difficulties with this product. Also, your details are added to our customer database so that you automatically receive new product brochures as and when they are released.

3. Summary of Features

GPS

Receiver type:	12 Parallel channels
Frequency:	1575.42 MHz +/- 1 MHz (C/A code), L1
Sensitivity:	-130dBm
Signal acquisition:	Automatic
Time to first fix:	15 minutes maximum, typically 2 minutes

Standard GPS

Position accuracy:	<i>15 m RMS. (L1, C/A code HDOP <2.5 without SA)</i>
Speed accuracy:	<i>1 knot RMS. (L1, C/A code HDOP <2.5 without SA)</i>

Differential GPS

Position accuracy:	<i><7.5 m RMS. (L1, C/A code HDOP <2.5 with SA)</i>
Speed accuracy:	<i>0.5 knot RMS. (L1, C/A code HDOP <2.5 with SA)</i>

Geodetic Datum:	WGS-84 (190 alternatives programmable)
Power Requirements:	13.6 VDC, 0.3 A nominal (10-16 V input range)
Cable length:	15 m (49 ft 3 in)
Operating Temp.:	-10 to 70°C (14 to 158°F)
Storage Temp.:	-10 to 70°C (14 to 158°F)
CE mark:	Conforms to 89/336/EEC(EMC), EN60945:1997

Data Input/Output:	
NMEA Mode	NMEA0183 V2.3 Output Non-isolated NMEA Input
SeaTalk mode	SeaTalk Bus
Memory Backup:	Lithium battery (10 year life)

Disposal Note: Care should be taken when disposing of this equipment as a Lithium battery is fitted internally. Local regulations may apply and must be adhered to.

Differential Beacon Receiver

Frequency Range:	283.5 to 325.0 kHz
MSK Bit Rate:	50, 100, 200 bps
Frequency Resolution:	0.5 kHz
Sensitivity:	2.5 μ V/m @ 10dB SNR @ 100 bps
Frequency Selection:	Automatic / Manual (user-selectable)

4. Raystar 114 Installation

The Raystar 114 is designed to receive the signals emitted from the satellites in a direct path. Ideally, the unit should be mounted upright in a location that is open and clear of any masts, search lights, or other structures that could block the line-of-sight reception of the antenna unit. The height of the receiver is not as important as the receiver having a clear view horizon to horizon for optimum signal reception. In fact, the lower the unit can be mounted and have a clear view to satellites, the better. The more stable the internal GPS antenna, the easier it is to track satellites lower to the horizon.

Installation of the Raystar 114 should only be undertaken by a competent installer.

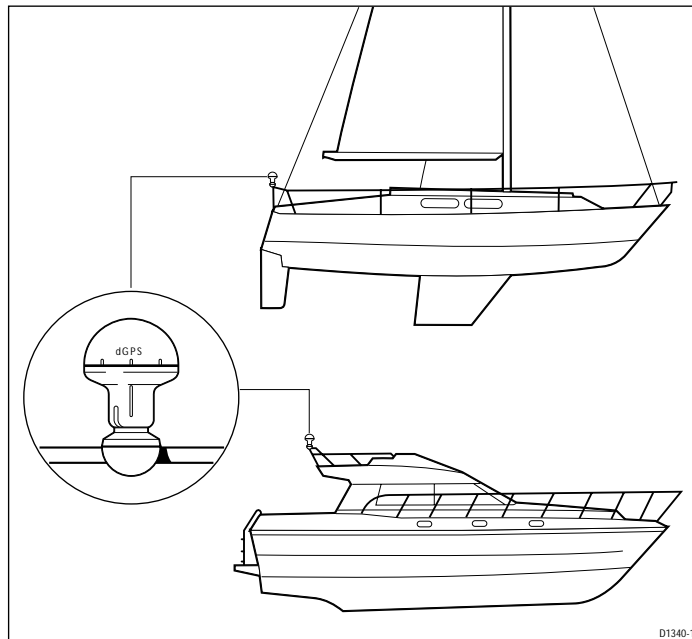

The unit should be separated by at least 7ft (2m) from other communication antennas and should not be mounted in the direct path of a Radar's antenna beam.

While planning the location for the unit, consider finding a convenient pathway for running the interconnecting cable which will connect the receiver to the GPS display unit or to the rest of an integrated system.

Ideally the cable should be run in a manner so that it can be hidden from view and, if possible, be in a direct path to the point of connection. It is important to keep the cable separated from other shipboard cables as much as possible to prevent interference pick-up.

A Surface mounting and rail mounting kit is supplied. When mounting the receiver unit flush to a deck surface avoid areas where the unit will be walked on or where it may become a tripping hazard.

CAUTION

Care should be taken that the unit is sited to avoid personal injury caused by falling on the aerial.

Note: *Mounting on the mast of a sailboat is not recommended.*

Grounding the System

For optimum operation the unit should be connected to the ships ground system.. You can ground the unit using one of the following three methods:

1. A 24 AWG wire can be connected via the screw connection found in the base of the unit, as shown in the following illustration.

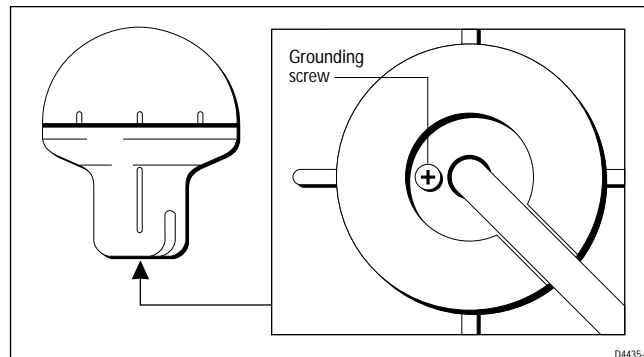

2. The cable screen can be connected to ground.
Note: *This will require the insulation to be cut back to obtain access to the screen.*
3. A conducting pole mount, which is connected to ground, can be screwed into the base of the unit.

Mounting

The Raystar 114 can be mounted on a pole. Alternatively, you can use the kit supplied to surface mount or rail mount the unit.

The aluminium base of the Raystar 114 has received a chromation treatment which adds toughness, resistance to wear and tear, and resistance to corrosion of the assembly.

The base of the sensor has a slot cut into it to feed the pre-wired cable externally of the mount. If the cable is fed through this slot, it should be secured with a cable tie to the base of the unit.

If you prefer to feed the cable through the mount, it will be necessary to cut the cable as the connector will not feed-through. You should re-connect the cable using a connector block, refer to the *Connections* section for cable details.

The cable assembly supplied is 15m (49ft 3in) in length with a moulded 6-pin connector fitted at the receiver end. The cable should be run as directly as possible to the navigation console or to the external navigation device. The cable can be cut as necessary to the required length, or coiled and stored out of the way. Refer to the *Connections* section for cable details .

Pole Mount

The Raystar 114 can be mounted on a pole with an industry standard 1" 14 TPI thread as follows:

1. Screw the Raystar 114 unit onto the mount by hand, paying attention to avoid curling, tight loops, and kinking of the cable.
2. When the unit is fully threaded on the mount use a proper sized spanner and protective cloth to grip the base and tighten the unit to the mount.

Surface Mount

The Raystar 114 can be surface mounted as described below. Numbers in parenthesis refer to the illustration on the following page.

1. If necessary, pass the cable through the threaded connector (2) and screw the threaded connector (2) fully to the unit (1).
2. Fit the nut (5) to the retaining ring (4), if necessary thread onto the cable and position the retaining ring (4) as required.
3. Outline the two screw holes and drill to 4mm diameter.

4. Position the seal (6) and use the two screws (3) to secure the retaining ring (4) to the seal and mounting surface.
5. Screw the unit (1) and the retaining ring (4) together, tightening by hand until secure.

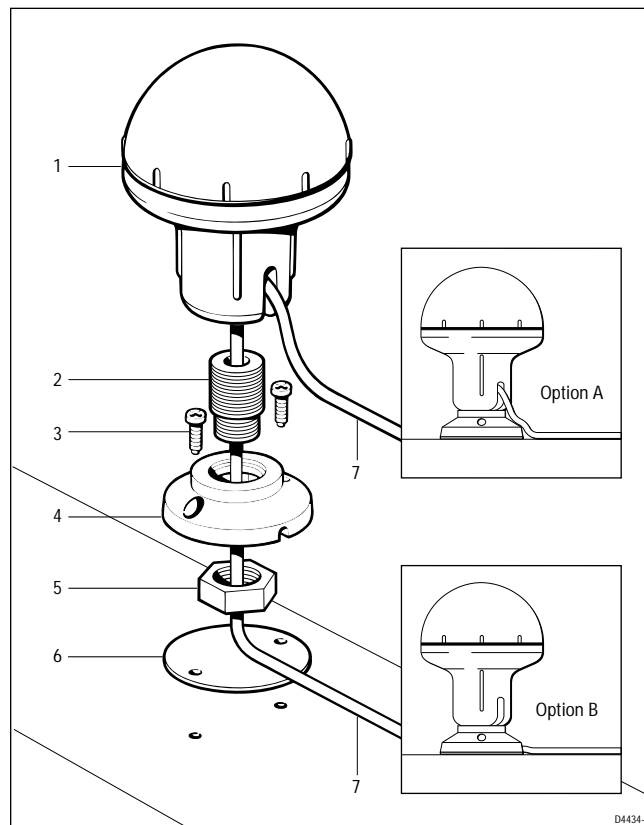

1 Sensor 2 Threaded connector 3 Screws 4 Retaining ring 5 Nut 6 Seal 7 Cable

Rail Mount

The Raystar 114 can be rail mounted as described below. Numbers in parenthesis refer to the illustration on the following page.

1. If necessary, pass the cable through the threaded connector (2). Screw the threaded connector (2) fully to the unit (1).
2. Fit the nut (5) to the retaining ring (4) and if necessary, thread onto the cable.

3. Hold the rail clamp (8) below the rail and place the seal (6) on top of the rail clamp. Use the screws (3) to secure the retaining ring (4) to the seal and rail clamp.

Note: Use the packing pieces (7) for rails between 23mm and 25mm (7/8in and 1in) diameter.

4. Screw the unit (1) into the retaining ring (4), tightening by hand until secure.
5. Making sure that the unit is upright, tighten the grub screw (9) against the rail.

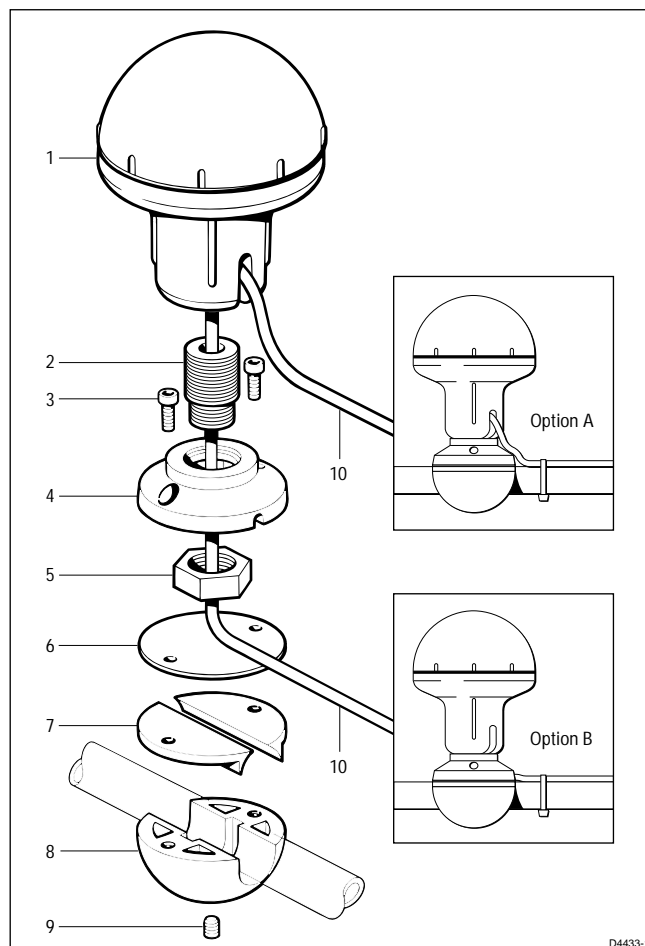

1 Sensor **2** Threaded connector **3** Bolts **4** Retaining ring **5** Nut **6** Seal **7** Spacers
8 Rail Clamp **9** Grub screw **10** Cable

Aerial

Screw the whip aerial into the unit. Hand tighten then, holding the plastic dome to prevent rotation, use a 13mm spanner to tighten the whip aerial an additional $\frac{1}{4}$ -turn. DO NOT overtighten.

Note: For optimum performance, use only the aerial supplied. Do not fit an aerial supplied by a third party.

Connections

The unit is normally connected to an NMEA system via a 15m (49ft 3in) cable terminated with a moulded 6-pin connector. Alternatively, connection can be made to other types of NMEA connector or a SeaTalk bus (see below).

If you have equipment with a dedicated GPS socket that accepts this connector, you should use it. If it is not possible to use this connector, remove the 6-pin connector and re-connect the cable using a connector block, referring to the diagram and connection table below.

As with all onboard marine equipment, the installer should ensure that the power supply connection to the RayStar 114 is adequately protected by a suitably rated fuse or circuit breaker. This will be provided, typically, by connection via a fused display unit.

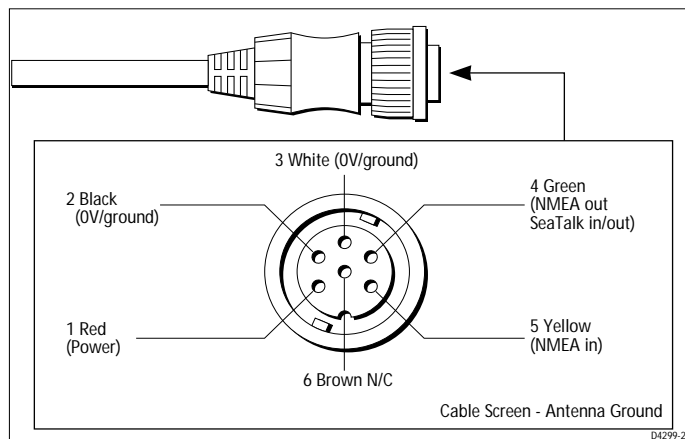

RayStar 114, NMEA and SeaTalk Interconnection Table

RayStar 114		NMEA	SeaTalk	
Pin No	Colour	Function	Function	Colour
1	Red	Power	Power	Red
2	Black	0V / Ground	0V	Screen
3	White	0V / Ground	0V	Screen
4	Green	NMEA Out	Data	Yellow
5	Yellow	NMEA In	Power	Red
6	Brown	Not Used	Not Used	-

Note: *Unused wires must be insulated and taped back.*

NMEA Sentences

Output	Input
GPGGA	GPMSK
GPGSA	
GPGSV	
GPGLL	
GPRMC	
GPVTG	
GPDTM	
GPMSS	
PRAYA	

Limited Warranty Certificate

Raytheon Marine Company warrants each new Light Marine/Dealer Distributor Product to be of good materials and workmanship, and will repair or exchange any parts proven to be defective in material and workmanship under normal use for a period of 2 years/24 months from date of sale to end user, except as provided below.

Defects will be corrected by Raytheon Marine Company or an authorized Raytheon dealer. Raytheon Marine Company will, except as provided below, accept labor cost for a period of 2 years/24 months from the date of sale to end user. During this period, except for certain products, travel costs (auto mileage and tolls) up to 100 round trip highway miles and travel time of 2 hours, will be assumed by Raytheon Marine Company only on products where proof of installation or commission by authorized service agents, can be shown.

Warranty Limitations

Raytheon Marine Company Warranty policy does not apply to equipment which has been subjected to accident, abuse or misuse, shipping damage, alterations, corrosion, incorrect and/or non-authorized service, or equipment on which the serial number has been altered, mutilated or removed.

Except where Raytheon Marine Company or its authorized dealer has performed the installation, it assumes no responsibility for damage incurred during installation.

This Warranty does not cover routine system checkouts or alignment/calibration, unless required by replacement of part(s) in the area being aligned.

A suitable proof of purchase, showing date, place, and serial number must be made available to Raytheon Marine Company or authorized service agent at the time of request for Warranty service.

Consumable items, (such as: Chart paper, lamps, fuses, batteries, styli, stylus/drive belts, radar mixer crystals/diodes, snap-in impeller carriers, impellers, impeller bearings, and impeller shaft) are specifically excluded from this Warranty.

Magnetrons, Cathode Ray Tubes (CRT), hailer horns and transducers are warranted for 1 year/12 months from date of sale. These items must be returned to a Raytheon Marine Company facility.

All costs associated with transducer replacement, other than the cost of the transducer itself, are specifically excluded from this Warranty.

Overtime premium labor portion of services outside of normal working hours is not covered by this Warranty.

Travel cost allowance on certain products with a suggested retail price below \$2500.00 is not authorized. When/ or if repairs are necessary, these products must be forwarded to a Raytheon Marine Company facility or an authorized dealer at owner's expense will be returned via surface carrier at no cost to the owner.

Travel costs other than auto mileage, tolls and two (2) hours travel time, are specifically excluded on all products. Travel costs which are excluded from the coverage of this Warranty include but are not limited to: taxi, launch fees, aircraft rental, subsistence, customs, shipping and communication charges etc..

Travel costs, mileage and time, in excess to that allowed must have prior approval in writing.

TO THE EXTENT CONSISTENT WITH STATE AND FEDERAL LAW:

(1) THIS WARRANTY IS STRICTLY LIMITED TO THE TERMS INDICATED HEREIN, AND NO OTHER WARRANTIES OR REMEDIES SHALL BE BINDING ON RAYTHEON MARINE COMPANY INCLUDING WITHOUT LIMITATION ANY WARRANTIES OF MERCHANTABILITY OR FITNESS FOR A PARTICULAR PURPOSE.

(2) Raytheon Marine Company shall not be liable for any incidental, consequential or special (including punitive or multiple) damages.

All Raytheon Marine Company products sold or provided hereunder are merely aids to navigation. It is the responsibility of the user to exercise discretion and proper navigational skill independent of any Raytheon equipment.

United States of America

Raytheon Marine Company
Recreational Products
676 Island Pond Road
Manchester, NH 03109-5420
U.S.A.

Tel 603-647-7530
Fax 603-634-4756

UK, Europe, Middle East, Far East

Raytheon Marine Company
Recreational Products
Anchorage Park, Portsmouth
PO3 5TD, England

Tel (44) 1705 693611
Fax (44) 1705 694642
Fax Customer support (44) 1705 661228

Raytheon

Factory Service Centers

United States of America

Raytheon Marine Company
address as above

UK, Europe, Middle East, Far East

Raytheon Marine Company
address as above

Stick barcode label here

Purchased from _____

Purchase date _____

Dealer Address _____

Installed by _____

Installation date _____

Commissioned by _____

Commissioning date _____

Owner's name _____

Mailing address _____

This portion of card should be completed and retained by the owner.