

Distributed by
Raymarine

Any reference to Raytheon or RTN in this manual should be interpreted as Raymarine. The names Raytheon and RTN are owned by the Raytheon Company.

Autohelm

ST80 Masterview

User's Manual

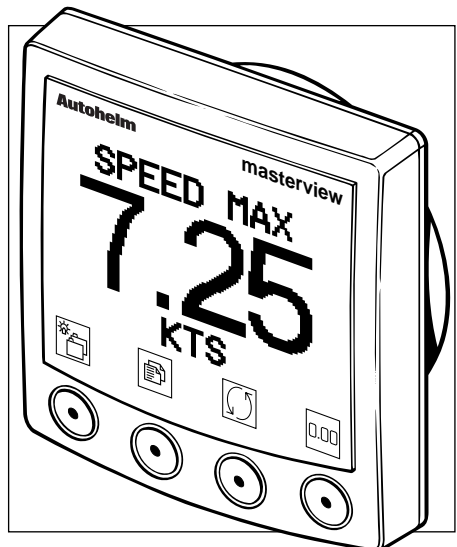

Package Contents

The ST80 Masterview package contains the following standard items:

1. Masterview display head
2. Sun cover
3. Thumb nuts (2)
4. Fixing studs (2)
5. SeaTalk cable 0.38m (1.2ft)
6. Gasket
7. Cue card
8. Installation guide
9. Operation and Setup manual
10. Worldwide Service Centre booklet
11. Warranty card

Items missing ?

If any of the above items are missing, please contact your Autohelm dealer or our Product Support Department. **Please note that items cannot be replaced without proof of purchase.**

Registering this Product

Once you have checked that you have all of the listed components, please take the time to complete the warranty document and return it to your national distributor.

By returning this document you will receive prompt and expert attention should you ever experience any difficulties with this product. Also, your details will be added to our customer database so that you automatically receive new product brochures as and when they are released.

Contents

Chapter 1: Introduction	15
1.1 General	15
1.2 First-Time Power-Up	19
Points to remember... ..	19
Sail Mode	20
Power Mode	21
1.3 Operation	22
About this Chapter	22
Points to remember... ..	22
Speed Chapter	22
Boat Speed Page	23
VMG to Wind Page	23
Trip/Log Page	24
Trip Control Page	24
Average/Maximum Speed	25
Average Speed	25
Maximum Speed	25
Speed Histogram	26
Sea Temperature	26
Depth Chapter	27
Water Depth	27
What if the depth echo is lost?	27
Depth Alarm Control	28
Editing the Depth Alarms	28
Minimum Depth	29
Depth Offset	29
Fish Finder	30
Rate	31
Sensitivity (SENS) and Gain	31
Sensitivity	31
Gain	31

- Depth Histogram 32
- Wind Chapter 32
- True Wind 33
- Alarm Control 33
- Alarm Adjustment 33
- Apparent Wind 34
- Alarm Control 34
- Alarm Adjustment 34
- Beaufort Scale 35
- True Wind Histogram (Speed and Angle) 35
- Docking (Power and Custom Modes only) 36
- Apparent Wind Steer 36
- Locked Mode 36
- Adjusting a Locked Apparent Wind Steer 37
- Autopilot Locked 37
- Heading Chapter 38
- Heading and Course Over Ground 38
- Tack Course 39
- Heading Steer 40
- Unlocked Mode 40
- Off Course Alarm 40
- Locked Mode 41
- Adjusting a Locked Heading 42
- Heading Histogram (True and Course Over ground) 42
- Navigate Chapter 43
- Chapter Structure 43
- General Route and Waypoint Information 43
- Entering Information 43
- Waypoints 44
- Entering New Waypoints 44
- Editing a Waypoint 45
- Deleting a Waypoint 46
- What if the Waypoint is Used in Routes? 46

Adding Event Marks	47
Route Page	47
Creating a Route	48
Deleting Waypoints from a Route	50
What if I Decide that I Don't Want to Delete the Waypoint?..	50
Inserting a Waypoint in a Route	51
Tracking to a Route Selected from the Route List.....	51
Waypoint Advance	52
Deselecting a Route	52
Reversing the Direction of a Route	52
Deleting a Route	52
Editing an Active Route	52
Copying a Route to the 'External Route' Entry	53
Capturing Single Waypoints	54
General Route Information	54
Operation in Dead-Reckoned Mode	54
Leg Information	55
Single Waypoint Page	55
Creating a Single Destination Waypoint	55
Selecting a Field to Edit	56
Tracking to a Single Waypoint	57
Navigate Page	57
Selecting Lines	58
Steering Page	58
Cross Track Error	58
Course Deviation Indicator (CDI)	59
Selecting Lines	60
What if a Target Waypoint does not Exist?	60
Position Page	60
SeaTalk Lat/Lon Data Available	60
No SeaTalk Lat/Lon Data Available	61
Dead Reckoning (DR) Control	61
Log Information	62

General Page	63
Tide	63
Speed, Heading, Course Over Ground, Speed Over Ground ..	63
Speed and Heading	64
Speed Over Ground and Course Over Ground	64
Local Time	64
Fix Status	65
Pilot Chapter	65
Status Page	66
Navigate Page	66
Cross Track Error (XTE)	67
Course Deviation Indicator (CDI)	68
What if a waypoint is not selected?	69
Auto Steer	69
Vane Steer	70
General Page	71
Tide	71
Speed, Heading, COG and SOG	71
Time	72
Wind	72
Pop-Up Pilot Chapter	73
Response	73
Rudder Gain	74
Autopilot Status	74
Course Change	74
Auto Tack	75
Starboard Tack	75
Port Tack	75
Check Tack	76
Track and Waypoint Advance	76
Old Heading	77
Old Wind Angle	77
Timers Chapter	78

UTC Page	78
Local Time Page	78
Modifying Local Time	79
Changing the Format	79
Local Time Alarm Control	79
Alarm Timer Page	80
Stopwatch Page	80
Running Mode	81
Stopwatch Reset	81
Lap Timer	81
Resetting the Lap Timer	82
Split Time	82
Starting Another Lap Time	82
Race Timer	83
Countdown Mode	83
Count-up Timer (Race Running Mode)	84
Race Reset	84
Race Lap Mode	84
Lap Reset Mode	85
Split Race Time	85
Environment Chapter	86
SeaTalk Voltage Histogram	86
Sea Temperature Histogram	86
Nav Status Chapter	87
Data Source Page	87
Fix Status Page	88
General Information Page	88
Satellite Plot Page	89
Split Screen Mode	89
Multiline Chapter	90
Line Edit	91
Chapter Edit	92
Maxiview Remote Chapter	93

Maxiview Remote Control Page	93
Illumination Selection and Adjustment	94
Alarms	95
Alarm Recognition	95
Recognised Autopilot Alarms	96
High Priority Alarms	96
Identifying High Priority Audible Alarms	96
Low Priority Alarms	97
Identifying Low Priority Audible Alarms	97
ST80 Watch Alarm	97
Timer Alarm	98
Man Overboard (MOB)	98
Dead Reckoned MOB Data (Default)	98
Lat/Lon MOB Data	99
Waypoint 999	99
No Valid MOB Data	100
Audible MOB Alarm	100
Keypad Handling	100
Navigator Keypad	100
Remote Keypad	100
Autopilot Keypad	100
Chapter 2: Setup	101
2.1 About this Chapter	101
2.2 Initial Start-up	101
Points to remember...	101
2.3 Entry into User Setup	102
2.4 Speed	102
Boat Speed Response	103
Adjusting Boat Speed Response	103
VMG Wind Response	104
Adjusting the Response	104
Boat Speed Units	104
Distance Units	105

Selecting Distance Units	105
Speed Trend Indicators	105
Adjusting the Current Trend Threshold	105
VMG Trend Indicators	106
Speed Display Format	106
Distance Display Format	106
Speed Transducer Calibration	106
Recording a Correction Factor Automatically	107
Manually Recording and Entering a Calibration Factor	109
Calibrating using Speed Over Ground (SOG)	110
2.5 Depth	111
Switching the Transducer ON and OFF	111
Response Page	111
Depth Units Page	111
Selecting Depth Units	112
Trend Indicators Page	112
Depth Display Format	112
Depth Offset Page	112
Setting the Offset	114
2.6 Wind	114
Wind Speed & Angle Response, Wind Speed Units & Display Format	114
Wind Speed Units	114
Wind Angle Offset Page	114
Procedure	115
2.7 Heading	116
Heading Response	116
Response Adjustment	116
Compass Linearisation	117
Procedure	117
Compass Offset Page	118
Adjusting the Offset	119
Variation	119

Adjusting Variation	120
True/Magnetic Heading	120
Changing the Heading	121
Heading Lock	121
2.8 Navigate	122
XTE Response	122
Adjusting XTE Response	122
Waypoint Arrival Radius	122
Adjusting the Radius	123
2.9 Pilot Setup	123
Pilot Calibrate Entry Screen	124
Vessel Type	124
Cal Lock	125
Rudder Gain	125
Rate Level	126
Rudder Offset	127
Rudder Limit	127
Turn rate	128
Default Speed	128
Off Course Limit	129
Trim Level	129
Power Steer	130
Drive Option	131
Rudder Deadband (Damping)	131
Variation	132
Auto Adapt	132
Latitude	133
Auto Release	134
Wind Trim Time Constant	134
Response	135
Unknown Cal Stage	135
Exiting Pilot Setup	136
2.10 Timers Setup	136

Race Start	136
Start Guns	137
2.11 Environment	137
Temperature Units	137
Temperature Offset	138
Adjusting the Offset	138
2.12 GPS Setup	138
2.13 Round Repeater	138
2.14 Multiline	139
2.15 Instrument Set-Up	139
Chapter Title Control, Pilot Icon, Key Beep & MOB	139
Chapter Title	139
Pilot Status Icon Control	140
Key Beep	140
Display Mode	140
Alarm control	141
Lamp Offset	141
Adjusting the Illumination Settings	142
Contrast	142
Adjusting the Contrast	142
Navigator Keypad Linking	143
Unlinking a Navigator Keypad	144
CodeLock	144
Entering a New Code	145
Turning CodeLock Off	145
Transducer List	146
Boat Type	146
Custom Chapter Selection	147
Selecting Pages	147
2.16 Quitting User Setup	148
Chapter 3: CodeLock	149
3.1 Introduction to CodeLock	149
3.2 Masterview Display Heads	150

Entering Your Chosen Code Number at Power-On	150
Automatic CodeLock Transmission (Auto)	150
3.3 Analogue Display Heads	150
Automatic CodeLock Systems	150
Manual CodeLock System	150
Entering the Code Number	151
What if you enter the wrong number?	151
Chapter 4: Problem Solving	152
4.1 Problem Solving	152
Display is blank - keypad not illuminated	152
Display is blank - keypad illuminated	152
No exchange of information between SeaTalk instruments .	152
Failure of a group of SeaTalk instruments	152
LCD shows “Code ON” when the power supply is switched on	152
Poor character definition	152
Chapter 5: EMC and Servicing Guidelines	153
5.1 Important information	153
5.2 Installation	153
5.3 Check Before Going to Sea	154
5.4 Servicing and Safety	154
Chapter 6: Specification	155
Index	157

ST80 System Overview

In today's world of marine electronics, we expect a more control at our fingertips.

Navigation receivers give our position, electronic chart plotters provide accurate chart information and autopilots keep us on track on long passages. Performance monitoring instruments tell us anything from speed over the water to the best course to steer to a target waypoint.

The problem with conventional instrumentation is that the more information you require the more space must be found to install the additional displays. Lack of space often leads to compromise – you can install the display where you can see it or where you can reach it – but not always both! You may also want to have access to several bits of information but the instrument to hand provides only one.

With ST80, all these limitations disappear. ST80 allows you to site displays exactly where you want them and to display as much or as little information as you require. Gone are the days when you wish you could make a display vanish to make way for the information you actually want — all you have to do is select the page of information on the display nearest to you.

Although ST80 is an extremely sophisticated and comprehensive electronics system, ease of use has not been compromised. Operation of the primary displays revolves around a chapters and pages concept — simply turn to the chapter containing the information you require and “flick” the pages until the appropriate page is displayed.

Chapter 1: Introduction

1.1 General

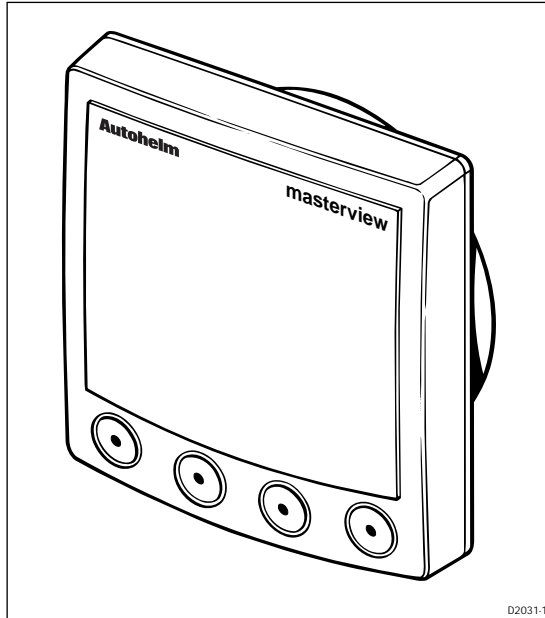

The Masterview is a powerful multi-function instrument capable of displaying SeaTalk data in alphanumeric and graphic formats.

Operation revolves around a “Chapters and Pages” concept. There are 11 chapters, each with multiple pages containing information related to the main chapter – a chapter is effectively an individual SeaTalk instrument. This allows you to configure display heads for different functions (for example, speed, depth, wind, position, heading).

The Masterview uses icons and screen prompts to guide you through the various chapters, pages and special functions. This approach makes the Masterview extremely easy to use.

When the Masterview is linked to an ST80 autopilot keypad, the Masterview becomes a fully featured autopilot control centre.

In addition to the Autopilot keypad, the Navigator and Remote keypads provide even more operating features. The Navigator allows you to create, review and edit alphanumeric waypoint data. The Remote allows you to operate the Masterview from a remote location.

Masterview Operation Guide

This chart shows the complete Masterview chapter and page configuration. Chapters and pages can be switched off to reduce the total number of displays.

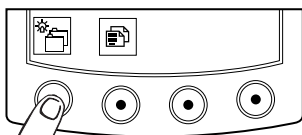

CHAPTERS

Use this key to cycle the available chapters.

You can return to the previous chapter pressing this key for 1 second - this action must be carried within 2 seconds when entering a new chapter.

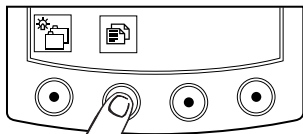

PAGES

Use this key to cycle pages within chapters.

Press this key for 1 second to return to the previous page.

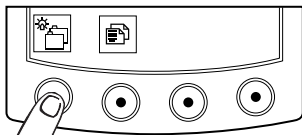

ILLUMINATION

Press this key for 1 second to switch the LCD illumination on.

Once the illumination is on, press this key momentarily to change the illumination settings.



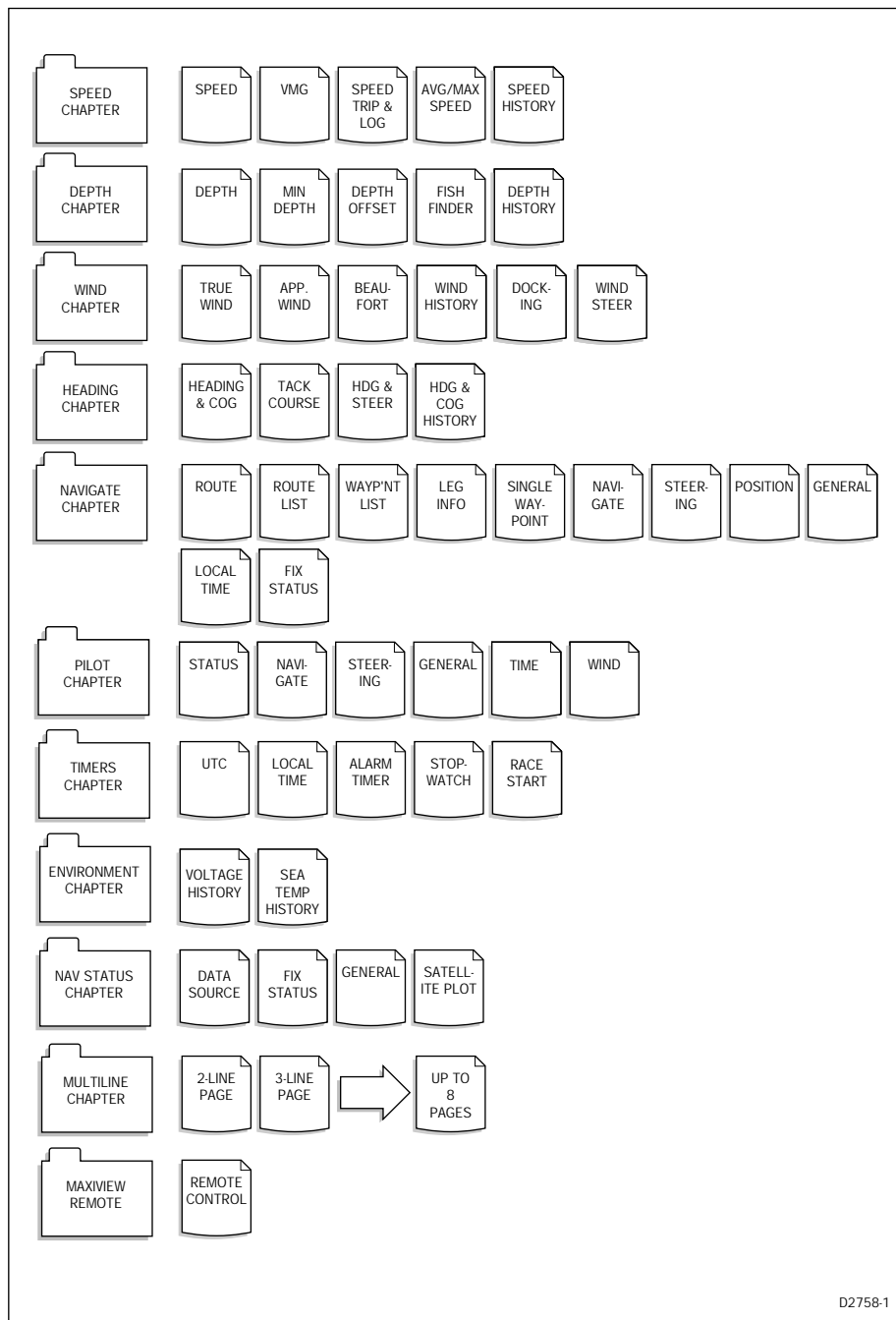

Icon Guide

The Masterview uses icons to identify specific keypad functions. The following list shows the complete range of keypad icons together with a brief description of the icons primary function(s).

	Cycle Chapters or turn illumination ON		Cycle or change		Insert WP or return to WP list & save changes		Change Chapter on selected Maxview
	Cycle Pages		Increase		Route select		Change page on selected Maxview
	Chapter		Decrease		Edit route		Select Maxview
	Illumination		Exit		Reverse route		Select Maxview
	Start		Edit Multiline chapter		Delete route		Change month format
	stop		Edit		Copy external route		Delete multiline page
	Heading or wind steer lock/unlock		Change to US date format		Track to waypoint		Change to 24hr clock
	Change history or timebase		Change to EURO date format		Stop tracking to waypoint		Change to 12hr clock
	Reset		* Autopilot STANDBY mode		Select alarm adjustment page		Auto linearise for log calibration
	Remove display pop-up		* Autopilot AUTO mode		Cancel alarms		Drop event mark
	CodeLock		* Autopilot TRACK mode		Edit alarms		
	Scroll up		* Autopilot VANE mode		Lap start		
	Scroll down		New waypoint		Lap stop		
	Yes, enable or turn ON		Edit waypoint		Lap reset		
	NO, disable or turn OFF		Delete waypoint		Synchronise race timer and guns		

* Displayed only when this option has been selected in User Setup

1.2 First-Time Power-Up

When the Masterview is powered up for the first time you are presented with the “SELECT TYPE” page.

Use this page to select your vessel type (sail or power).

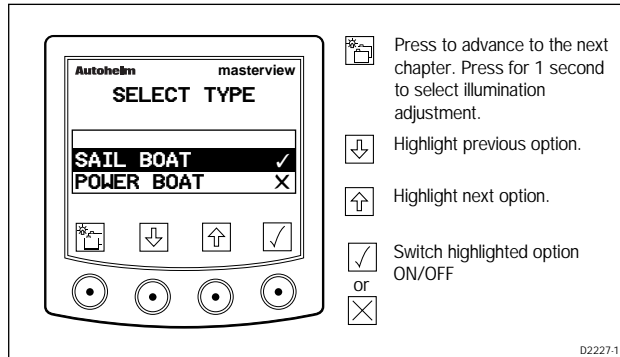

Points to remember...

- The selected operating mode is identified by a ✓.
- Non-selected operating modes are identified by a X.
- If a permanent selection has not been made, the “SELECT TYPE” display defaults to “SAIL”.

Sail Mode

The following flow chart shows the “SAIL” chapter and page configuration.

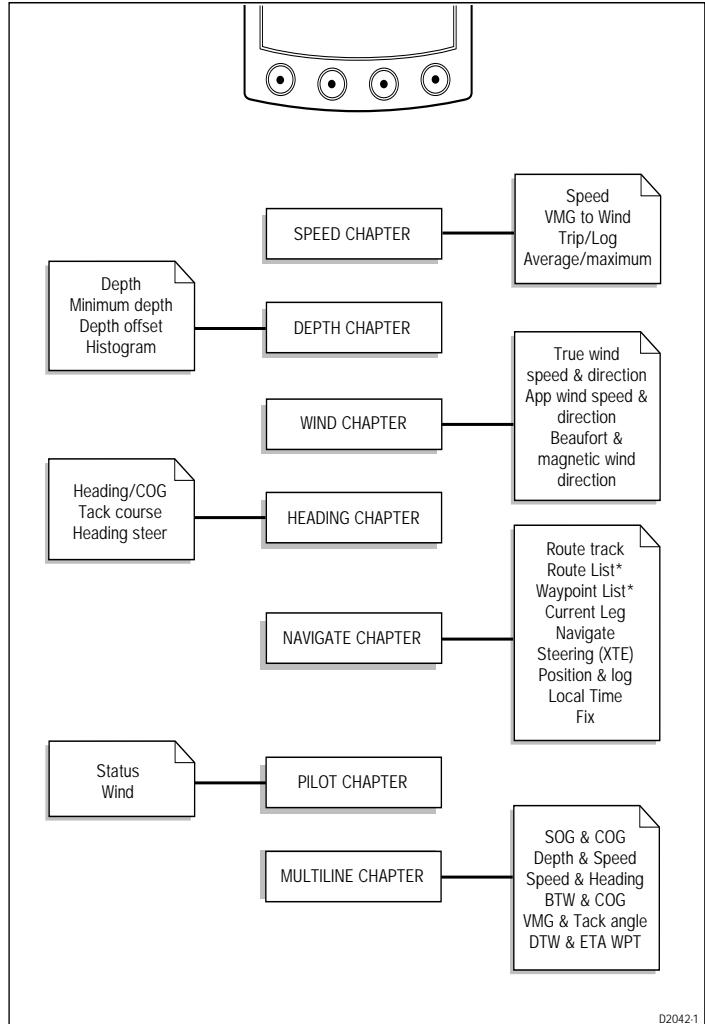

Chapters only appear if the associated transducer is transmitting information onto the SeaTalk bus.

Note: Chapters are turned off (and replaced with a warning page) if related SeaTalk data is lost for more than 2 seconds.

Pages identified by an asterisk (*) are only available if the Masterview has been linked to a Navigator keypad.

Power Mode

If “POWER” is selected, the following chapters and pages are available during normal operation.

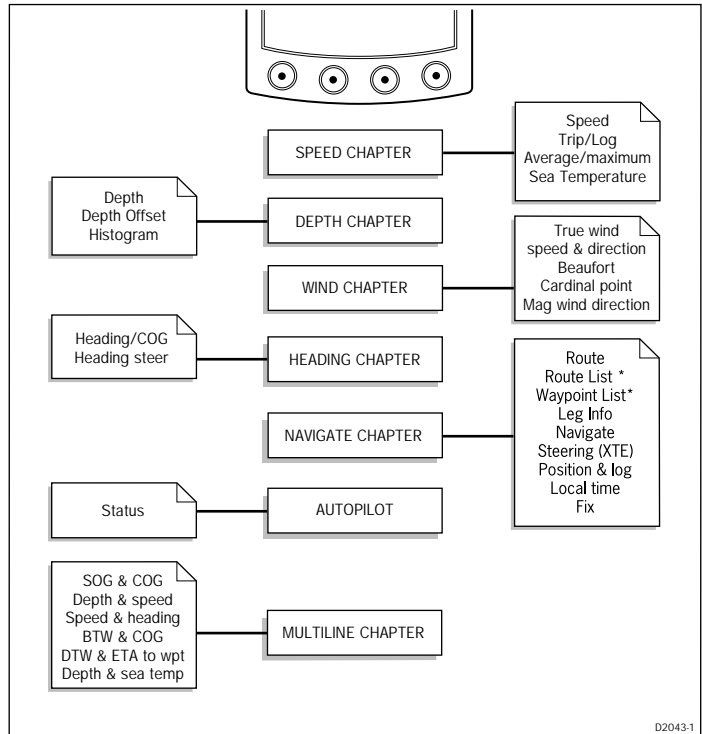

Chapters only appear if the associated transducer is transmitting information onto the SeaTalk bus.

Note: Chapters are turned off (and replaced with a warning page) if related SeaTalk data is lost for more than 2 seconds.

Pages identified by an asterisk (*) are only available if the Masterview has been linked to a Navigator keypad.

1.3 Operation

The chapter and page concept allows you to configure multiple display heads for different functions (for example, speed, depth, wind, position, heading) or, alternatively, a single head to display as much or as little data as you require.

About this Chapter

This chapter describes how to operate the Masterview using a combination of text, diagrams and flow charts.

The flow charts show the display roll-over for a particular key or key sequence. If a display is adjustable, related information follows the flow chart in display roll-over order.

Points to remember...

- All key presses in the flow charts are momentary (unless stated otherwise).
- You can return to the previous chapter by pressing the chapter key for 1 second, providing the chapter key is pressed within 2 seconds otherwise illumination adjustment will be turned on.

Speed Chapter

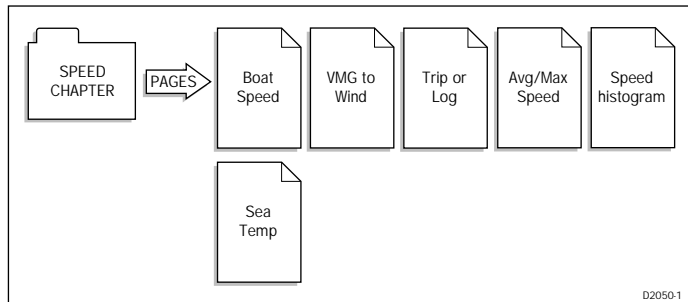

Boat Speed Page

The boat speed units can be displayed in KNOTS, MPH or KM/H. Units are selected in “User Setup”.

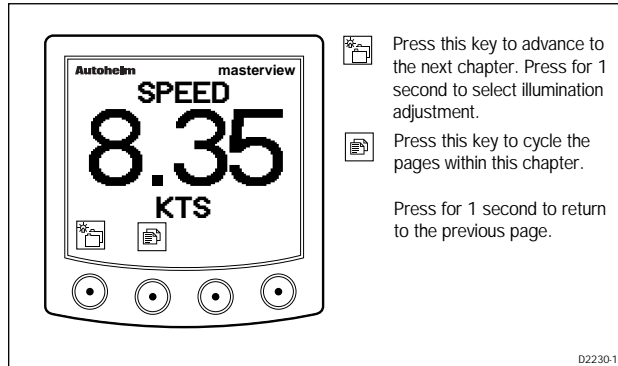

If the rate at which the boat speed changes is greater than the value assigned in User Setup, trend indicators ▲ (faster) ▼ (slower) are displayed alongside the units.

VMG to Wind Page

This page is not available in “Power” mode.

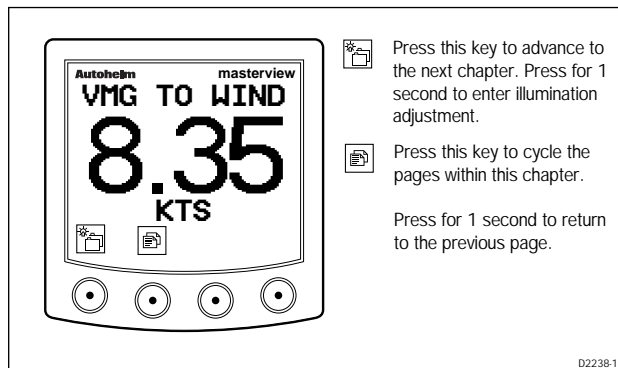

- The displayed units, Statute Miles, Nautical Miles or Kilometres, are dependent on the units selected in User Setup.
- If the rate at which VMG to Wind data changes is greater than the User Setup value, trend indicators ▲ (faster) ▼ (slower) are displayed.

Trip/Log Page

The Trip/Log page displays the current boat speed, the accumulated distance (log), and one of the five trip counters.

- The maximum recordable trip distance is 9999.9 nautical miles.
- The log records the total distance up to 99999.9 nautical miles.

Autohelm masterview

SPEED 8.35 KTS

TRIP 2 1102.4NM

- Next chapter. Press for 1 second to enter illumination adjustment.
- Next page or press for 1 second to return to the previous page.
- Show next active trip or the LOG display.
- Display trip list and control icons.

D2233-1

- Up to 5 trip distances can run at the same time.
- “TRIPS OFF” is displayed if the key is pressed when there are no currently active trips.
- The “TRIPS OFF” message is cleared by pressing any key.
- Log data is recorded every 30 minutes (this is a fixed period and cannot be adjusted).

Trip Control Page

This page displays up to 5 trips which can be scrolled, reset and switched ON/OFF as required. Operation of the trip functions is described and illustrated below.

Autohelm masterview

TRIP	ON/OFF	NM
1	OFF	0.00
2	ON	1102.4
3	OFF	20.19
4	OFF	0.00
5	OFF	50.84

- Return to Trip/Log display.
- Turn highlighted trip ON/OFF.
- Highlight next trip.
- Press for 4 seconds to reset the currently selected trip to zero.

D2236-1

Average/Maximum Speed



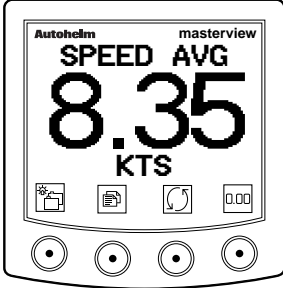

This page displays the average or maximum boat speed for the current journey.

Average Speed

Average boat speed is displayed in the units selected in User Setup.



Autohelm masterview
SPEED AVG
8.35
KTS

-  Go to the next chapter or press for 1 second to enter illumination adjustment.
-  Go to the next page. Press for 1 second to return to the previous page.
-  Toggle maximum & average speed.
-  Press for 4 seconds to reset the average speed to boat speed.

D2226-1



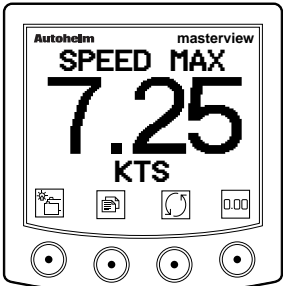

- If the average speed calculation stops for any reason, the display reads “STOPPED”.
- The display flashes for 4 seconds when the average speed is reset.

Maximum Speed

This page displays the maximum speed achieved during the current journey.



Autohelm masterview
SPEED MAX
7.25
KTS

-  Go to the next chapter or press for 1 second to enter illumination adjustment.
-  Press to go to the next page. Press for 1 second to go to the previous page.
-  Toggle maximum & average speed.
-  Press for 4 seconds to reset the maximum speed to zero.



D2781-1

- The display flashes for 4 seconds when the maximum speed is reset.

Speed Histogram

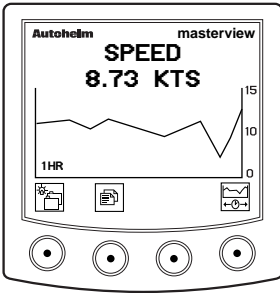
The histogram displays a graph of your boat speed for a selected period of time. The following illustration shows a typical example of a speed histogram.







-  Go to the next chapter. Press for 1 second to enter illumination adjustment.
-  Go to next page. Press for 1 second for previous page.
-  Select time scale for histogram 1 and 10min, 1hr, 6hr, 24hr.

D2234-1

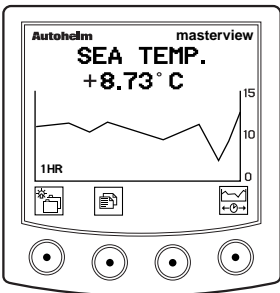
Sea Temperature

This page displays the current sea temperature as well as a graph depicting the sea temperature for a selected period of time.



-  Go to the next chapter. Press for 1 second to enter illumination adjustment.
-  Go to next page. Press for 1 second for previous page.
-  Select time scale for histogram 1 and 10min, 1hr, 6hr, 24hr.

D4137-1

Depth Chapter

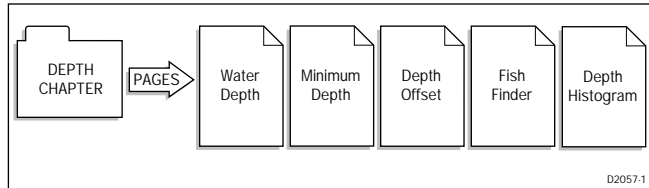

Water Depth

The depth can be displayed in feet, fathoms or metres. However, the currently displayed units are those selected in User Setup.

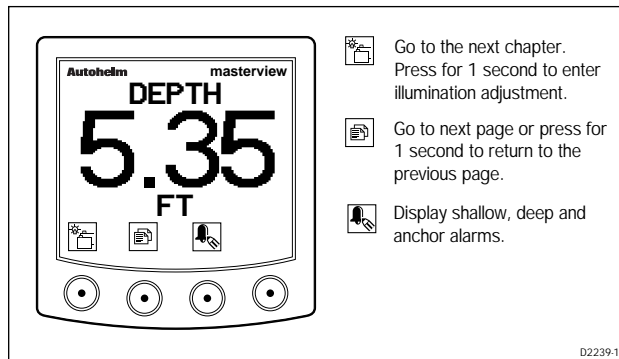

If the rate at which the water depth changes is greater than the value in User Setup, trend indicators ▲ (decreasing) or ▼ (increasing) are displayed alongside the units.

What if the depth echo is lost?

- The last valid echo remains on screen until a new valid echo is received.
- The words “LAST ECHO” are displayed.

Depth Alarm Control

The alarm control page displays the current settings for the shallow, deep and anchor alarms.

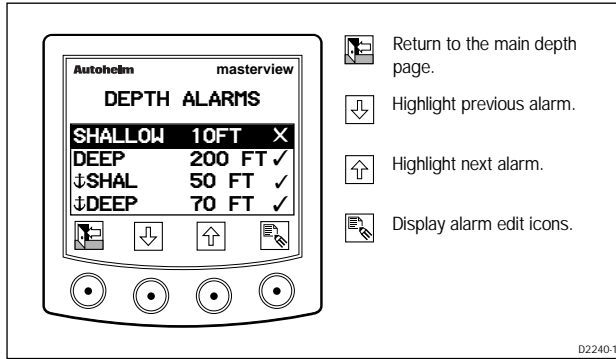

- Anchor alarms cannot be turned off individually.
- Anchor alarms are both on or both off.

Editing the Depth Alarms

Set the depth alarms using the keys as shown.

The depth alarms can be set and turned ON/OFF as follows:

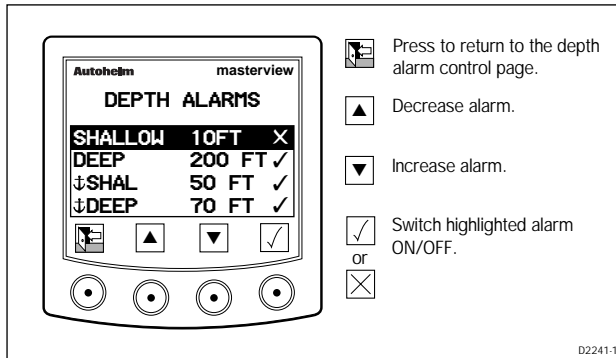

- The maximum depth is 122m (400ft) with a standard active depth transducer and 244m (800ft) with the “deep depth” transducer.
- The shallow alarm range is from 3 to 30ft (0.8 to 9m).
- The shallow alarm cannot be set above the deep alarm and the deep below the shallow.
- Conversions from feet to fathoms/metres are rounded up/down, for example, 4.2 feet = 1.3 metres or 0.7 fathoms.

Minimum Depth

This page displays the minimum depth recorded during the current journey.

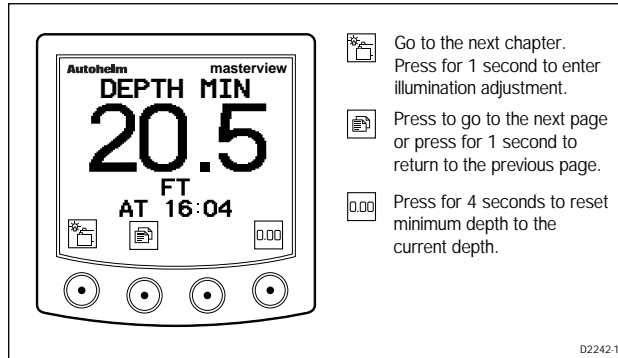

- This page also displays the time when the minimum depth was recorded, providing the required information is available.
- The display flashes for 4 seconds when the minimum depth is reset.

Depth Offset

Depth offset displays the amount and type of depth transducer offset: waterline (positive), keel (negative) or transducer (zero).

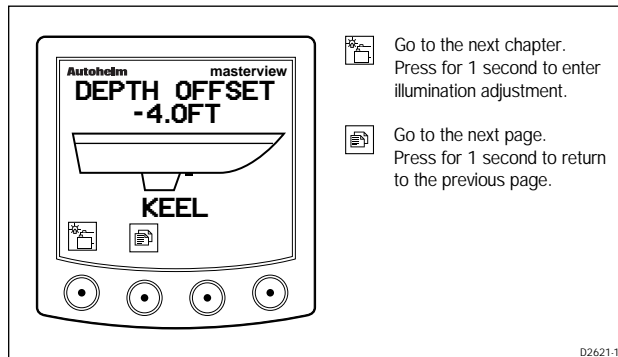

- Go to the next chapter. Press for 1 second to enter illumination adjustment.
- Go to the next page. Press for 1 second to return to the previous page.

Fish Finder

The fishfinder page displays a graphic representation of the sea-bed and the size of fish in the area of detection.

The default fish finder display shows:

- The current depth.
- A boat symbol to indicate the most recent data.

D2243-1

- Go to next chapter. Press 1 second to enter illumination adjustment.
- Press to go to next page. Press for 1 second to return to previous.
- Display split screen and show sensitivity and gain editing icons.
- Display split screen only.

When the split screen is selected, the rate, sensitivity and gain settings are displayed on the left.

D2244-1

- Go to the next chapter. Press for 1 second to enter illumination adjustment.
- Go to the next page. Press for 1 second to return to the previous page.
- Show sensitivity and gain adjustment icons.
- Adjust rate (range 1 to 8 plus OFF).

Note: The split-screen times-out to the full screen display after 8 seconds of keypad inactivity.

Rate

- Controls the speed at which the fish finder information is updated.
- The range is from 1 to 8 plus OFF (the fastest setting is 1).

Sensitivity (SENS) and Gain

To adjust sensitivity and gain, you must press  to change the current icons to the adjustment icons.

The  key is used to highlight sensitivity or gain as required.

Sensitivity

You can control the size of the fish that will be detected by adjusting the sensitivity.

- A high setting (the range is from 0 to 100) detects smaller fish.
- A lower setting detects larger fish.

Gain

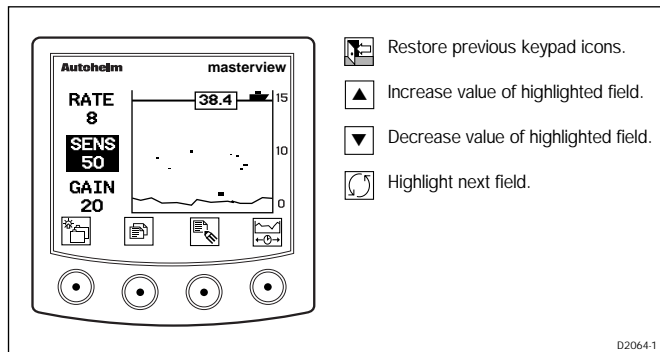

The amount of data displayed at any one time is governed by the gain setting — the higher the setting (the range is from 0 to 100) the more data is displayed.

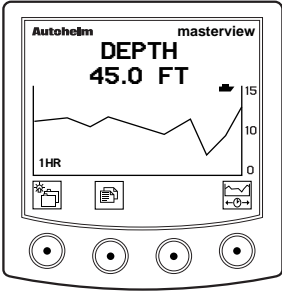

Depth Histogram

The depth histogram displays the current depth and a graph of the depth soundings for a selected period of time.



-  Go to the next chapter. Press 1 second to enter illumination adjustment.
-  Press to go to next page. Press for 1 second to return to the previous page.
-  Select time scale for histogram: 1min, 10min, 1hr, 6hr, 24hr.

D2245-1

Wind Chapter

The complete wind chapter consists of the following pages.

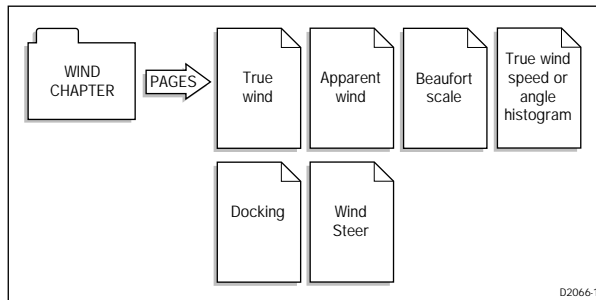

True Wind

This page displays the true wind speed and true wind angle relative to the ships head. The wind direction is identified by a P (port) or S (starboard) indicator.

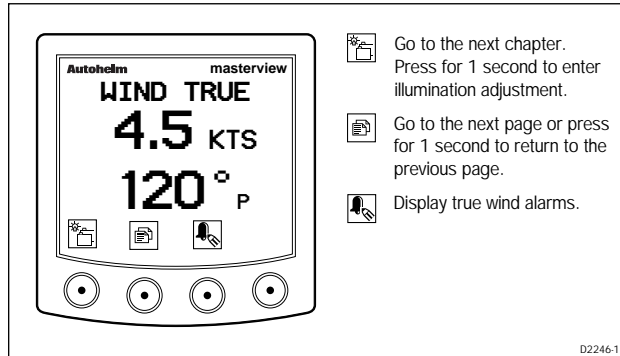

- Wind speed is “sailing wind speed”
- Wind angle is “relative sailing wind angle”.
- Alarms can be set for true wind to warn you of increasing or decreasing wind speeds and changes to the wind angle.

Alarm Control

Alarm control displays the current high and low speed, and high and low wind angle alarms.

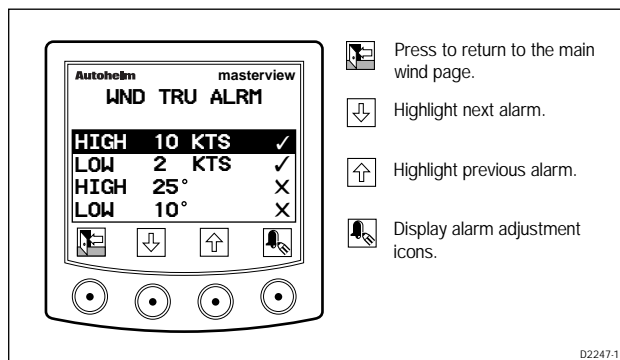

Alarm Adjustment

- The wind alarms can be turned ON and OFF as and when required.
- A highlighted alarm that is ON has a displayed above the right-hand key, and a when it is OFF. Press to turn an alarm “OFF” and to turn an alarm “ON”.

- Set the alarms using the ▲ or ▼ keys. The maximum wind speed is 60 knots.
- The maximum wind angle is 180°.
- Once you have adjusted an alarm, press  to return to the wind alarm display.

Apparent Wind

Apparent wind displays the apparent wind speed and wind angle. The wind direction is identified by a **P** for port or an **S** for starboard.

Alarms can be set for apparent wind to warn you when:

- the wind speed increases or decreases.
- the wind angle changes.

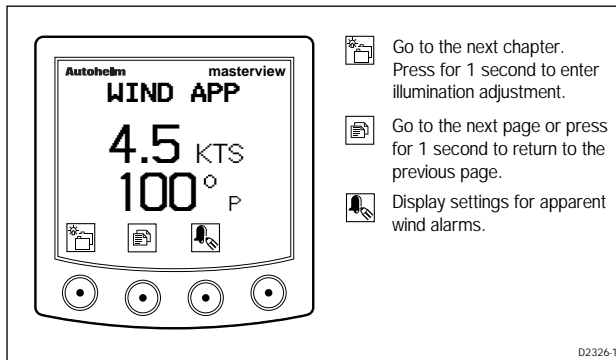

Alarm Control

This page displays the current settings the high and low speed and high and low wind angle alarms.

Alarm Adjustment

Adjustment is identical to true wind.

Beaufort Scale

This page displays true wind as a Beaufort scale. The wind angle (true or magnetic) and wind direction is also displayed.

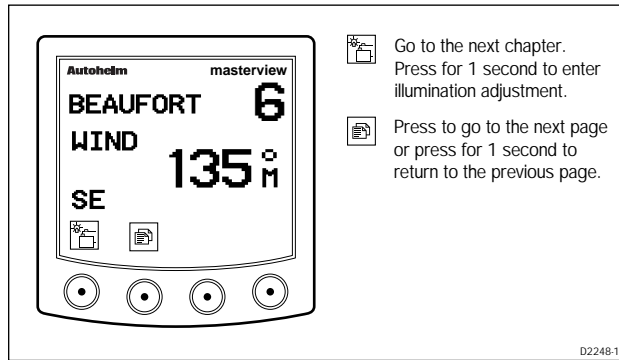

- If SOG is available, the Beaufort reading is taken from the ground wind speed and the wind angle from the true ground wind angle.
- If SOG is not available, the Beaufort reading is taken from the sailing wind speed and the wind angle from the true sailing wind angle.

True Wind Histogram (Speed and Angle)

The histogram displays a graph of the true wind speed and angle for a given period of time.

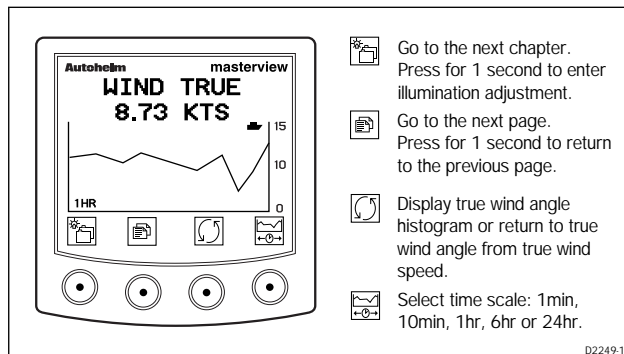



- Ground wind speed is recorded if SOG is available.
- Sailing wind speed is recorded if SOG is not available.
- Wind speed is shown in the currently selected units.

Note: This display is not active if you have selected “power” mode.

Docking (Power and Custom Modes only)

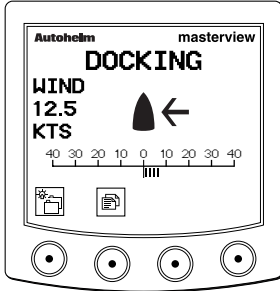
The docking page displays a graphic representation of the effect the wind is having on your vessel. The screen shows the wind speed and the wind direction.







-  Advance to next chapter or press for 1 second to adjust illumination.
-  Next page or press for 1 second to return to the previous page.

D405-1-1

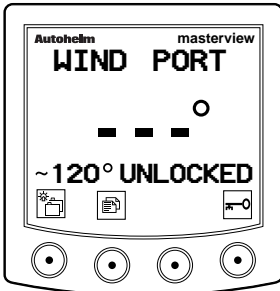
Apparent Wind Steer

The apparent wind steer pages operate in an almost identical manner to the heading steer pages.



-  Go to the next chapter. Press for 1 second to enter illumination adjustment.
-  Press this key to advance to the next page or press for 1 second to return to the previous
-  Press to store the current wind angle as the locked value. Enter locked mode.

D2255-1

- Apparent wind steer is not available if you have selected “power” mode.
- The current apparent wind angle is identified by ~ symbol.

Locked Mode

When lock mode is engaged, the apparent wind angle is stored as a datum. Any deviation from this datum is displayed together with a direction-to-steer indicator.

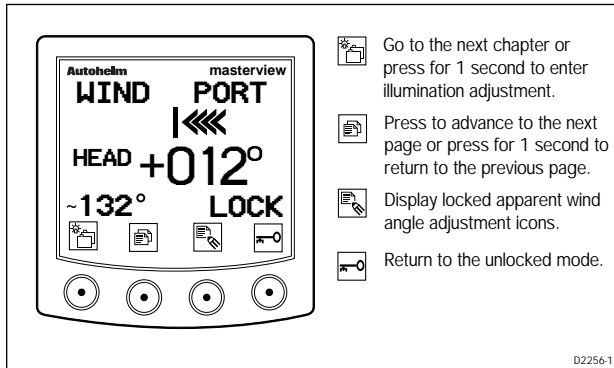

There are two operating modes: locked and fixed. These modes are similar to those described in Heading to Steer.

- A head/lift (freeing) indicator is displayed when applicable.

Adjusting a Locked Apparent Wind Steer

A “locked apparent wind steer” can be adjusted in 1° increments by entering “locked apparent wind control”.

Autopilot Locked

This page displays the difference between the autopilot “locked apparent” and “current apparent” wind angles. A steering indicator shows the direction to steer to correct any error.

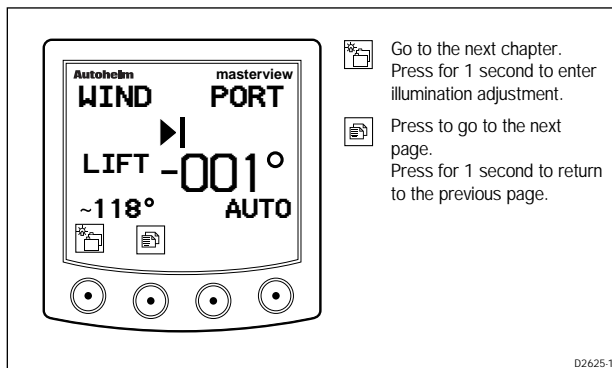

There are two operating modes: current and fixed.

- **Current:** the current “live” apparent wind angle (identified by a ~) is displayed at the bottom left of the display and the locked value as a positive (starboard) and a negative (port) reading up to 30°. The arrows indicate the direction to steer to correct any error.

- **Fixed:** the locked apparent wind angle is displayed at the bottom left of the display and the locked value as a positive (starboard) and a negative (port) reading up to 30°. The arrows indicate the direction to steer to correct any error.
- A head head/lift (freeing) indicator is displayed when applicable.

Heading Chapter

The heading chapter contains the following pages.

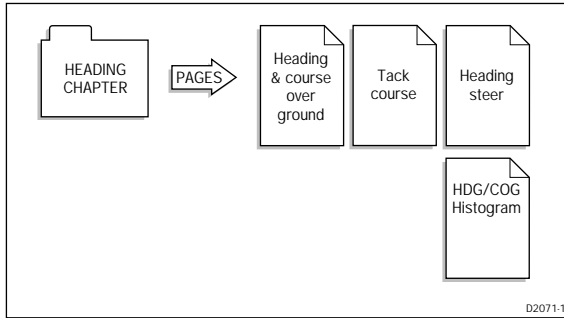



Heading and Course Over Ground

These pages display the heading and course over ground in degrees true or magnetic (depending on your selection in User Setup).

	Go to the next chapter. Press for 1 second to enter illumination adjustment.
	Go to the next page. Press for 1 second to return the previous page.
	Switch between heading and COG displays.



D2251-1



-  Go to the next chapter or press for 1 second to enter illumination adjustment.
-  Press this key to go to the next page. Press for 1 second to return to the previous page.
-  Switch between heading and COG displays.

Tack Course

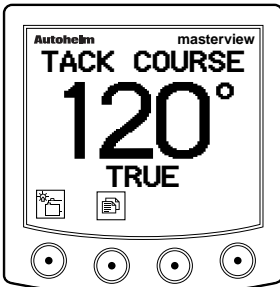
This page displays your tack course in degrees true or magnetic (depending on your selection in User Setup).



D2252-1

-  Go to the next chapter. Press for 1 second to enter illumination adjustment.
-  Go to the next page. Press for 1 second to return to the previous page.

- This page is not available if you have selected “power” mode.





Heading Steer

Heading steer allows you to lock onto a heading and view any subsequent changes between the locked and current headings.

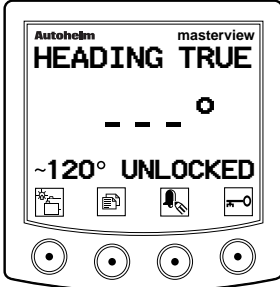
Unlocked Mode

This mode displays your current heading (identified by a ~) only.







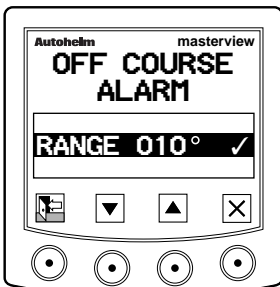

-  Go to the next chapter or press for 1 second to enter illumination adjustment.
-  Press to advance to the next page. Press for 1 second to return to the previous page.
-  Press to turn to the Off Course Alarm page.
-  Enter locked compass heading mode.

D2253-1

Off Course Alarm

An off-course alarm can also be set from the “heading steer” page. You can also turn an existing alarm off.



-  Press to return to the unlocked page and transmit alarm status.
-  Increases alarm in 1 degree increments.
-  Decrease alarm in 1 degree increments.
-  Turn the off-course alarm on/off.
- or
- 

D2622-1

- The maximum off-course alarm is 180°.

Locked Mode

In locked mode, this page displays the difference between a locked and current heading.

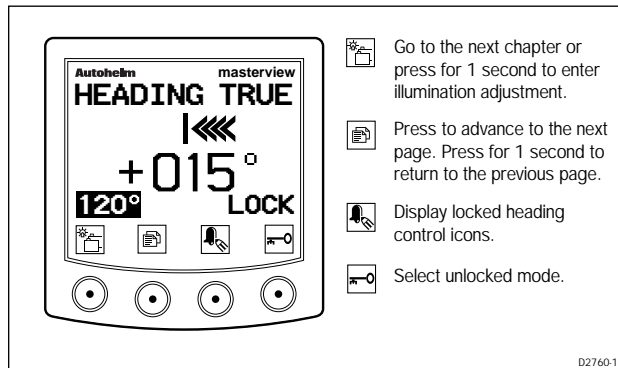

Locked mode can be configured in User Setup to show either the current or locked (fixed) heading.

- **Current:** the current “live” heading (identified by a ~) is displayed at the bottom left of the LCD and the difference between the locked and current as a positive (starboard) or a negative (port) value up to 30°. Arrows indicate the direction to steer to correct the error.
- **Fixed:** the locked heading is displayed at the bottom left of the LCD and the difference between the locked and current as a positive (starboard) or a negative (port) value up to 30°. Once again, arrows indicate the direction to steer to correct the error.

Adjusting a Locked Heading

A locked heading may be adjusted in 1° increments by entering “locked heading control” mode (below).

Autohelm masterview
HEADING TRUE
+015°
-120° LOCK

- Press to return to the previous display - the new locked heading is now active.
- Decrease locked heading.
- Increase locked heading.
- Select unlocked mode.

D2623-1

- If a SeaTalk autopilot is connected to the system, the “heading steer” page automatically switches from unlocked to locked mode when AUTO is engaged.
- The display identifies this change by displaying AUTO in the right hand corner of the screen.

Heading Histogram (True and Course Over ground)

The histogram displays a graph of the true heading and course over ground for a selected period of time.

Autohelm masterview
HEADING 120° TRUE
1HR

- Go to the next chapter. Press for 1 second to enter illumination adjustment.
- Go to next page. Press for 1 second to return to the previous.
- Switch between true heading and course over ground histograms.
- Select histogram time scale: 1min, 10min, 1hr, 6hr or 24hr.

D2257-1

Navigate Chapter

Chapter Structure

The Navigate chapter contains the following ‘pages’.

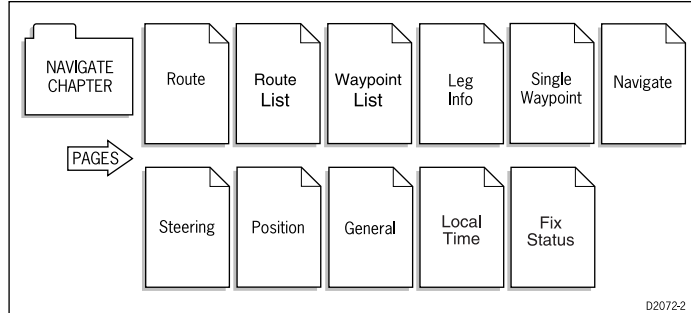

This chapter is handled in a different manner to the previous and subsequent chapters in this handbook. The reason for changing the approach is due to the way in which you have assemble route and waypoint data.

Before a route can be created, waypoints must be entered into the waypoint list. Once you have entered your chosen waypoints, a route can then be constructed.

General Route and Waypoint Information

The Navigate chapter allows you to:

- create up to 800 waypoints
- create and name up to 20 routes
- create up to 50 waypoints per route using Lat/Lon
- import a route from an external ‘navigator’
- create and track to a single destination waypoint

Note: The Masterview displays illustrated in this section are representations only.

Entering Information

Waypoint and route information is entered using the Autohelm Navigator keypad only.

If ST80 Masterview instruments have been linked to specific Navigator keypads, information can only be entered or modified using the linked units.

If linking has not taken place, information can be entered or modified from any Navigator keypad.

Waypoints

Before you begin to generate a route, you must create and store waypoints in the waypoint list.

Entering New Waypoints

Cycle the Navigate Chapter until you come to ‘Waypoint List’ and then follow the instructions below:

Entering New Waypoints

WAYPOINT LIST

BELL POINT
COMES

1

→

NEW WAYPOINT

NAME

LAT -

LON -

2

1 abc	2 def	3 ghi
4 jkl	5 mno	6 pqr
7 rst	8 uvw	9 xyz
ins	0	del
<div style="border: 1px solid black; width: 30px; height: 30px; margin: 0 auto; display: flex; justify-content: center; align-items: center;"> ↑ ← ↓ → </div>		

3

Use these keys to enter the name and co-ordinates for the new waypoint.
Each key cycles the number and the letters printed on that key (e.g. cycle of key 1 is 1, a, b, c, 1 etc.)

Use these keys to insert or delete data at the cursor position.

Use the multi-directional trackpad keys to move the cursor.

NEW WAYPOINT

NAME NAB TOMER
LAT 001.57,00 W
LON 050-40,00 N

4

→

WAYPOINT LIST

BELL POINT
COMES
NAB TOMER

5

NEW_WPT

- If the waypoint catalogue is full, the new waypoint icon is disabled until a waypoint has been deleted from the catalogue.
- If you want to return to the waypoint list without adding the waypoint, simply press the exit () key.
- To return to the edit display and display dashes, press delete X.

Editing a Waypoint

Cycle the display until you come to 'Waypoint List' and then follow the instructions illustrated below:

Editing a Waypoint

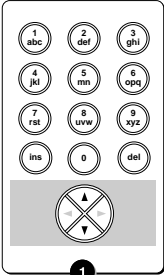

1

Scroll - Use the Navigator up or down key to highlight the waypoint, or press any alphanumeric key to open the 'Waypoint Search' feature.

Search - Use the Navigator keypad to enter the first character of the waypoint name. If there are multiple waypoints beginning with that letter, type in additional characters until the required waypoint is highlighted.

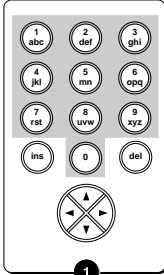

1

WAYPOINT LIST

BELL POINT
COMES
NAB TOWER

2



EDIT WAYPOINT

NAME NAB TOWER
LAT 001:57.00 W
LON 050:40.00 N

3

Move the cursor to highlight the data to edit using the Navigator keypad cursor keys.

4

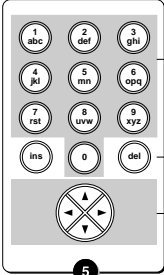

5

Use these keys to enter new waypoint data. Each key cycles the number and the letters printed on that key (e.g. cycle of key 1 is 1, a, b, c, 1 etc.)

Use these keys to insert or delete data at the cursor position.

Use the multi-directional trackpad keys to move the cursor.

EDIT WAYPOINT

NAME NAB TOWER
LAT 001:57.00 W
LON 050:40.00 N

6



Press to return to the Waypoint List without making changes or...

WAYPOINT LIST

BELL POINT
COMES
TAB TOWER

7



Press to return to the Waypoint List and save changes.

EDIT/WPT

- If a target waypoint (identified in the waypoint list by the letter 'T') is being tracked, then the edit key is disabled and that particular waypoint cannot be edited.
- If the waypoint is used in a route, a message similar to "WP USED IN 4 ROUTES CHANGE ALL?" will be displayed before the changes are saved.

Deleting a Waypoint

Cycle the display until you come to 'Waypoint List' and then follow the instructions illustrated below:

Deleting a Waypoint

WAYPOINT LIST

BEMBRIDGE
BOURNMOUTH
BOURNING
BRICKLESHAM BAY
CHERBOURG
CHICHESTER

1

1 abc	2 def	3 ghi
4 jkl	5 mn	6 opq
7 rst	8 uvw	9 xyz
ins	0	del

2

Scroll - Use the Navigator up or down key to highlight the waypoint to be deleted or press any alphanumeric key to open the 'Waypoint Search' feature...

Waypoint Search - Use the Navigator keypad to type in the first character of the waypoint to be deleted. If there are multiple waypoints beginning with that letter, type in additional characters until the required waypoint name is highlighted.

1 abc	2 def	3 ghi
4 jkl	5 mn	6 opq
7 rst	8 uvw	9 xyz
ins	0	del

2

WAYPOINT LIST

N.....

CHERBOURG
CHICHESTER
CHRISTCHURCH
LYMINGTON
NAB TOWER

3



EDIT WAYPOINT

NAME NAB TOWER
LAT 00:1.57,00 W
LON 050:40,00 N

4



EDIT WAYPOINT

DELETE
WAYPOINT?

5

YES

or

NO





DELWPCAT

What if the Waypoint is Used in Routes?

If the waypoint you want to delete is used in one or more routes, the message 'USED IN ROUTE' will be displayed and you will not be allowed to delete it.

To delete the waypoint it must first be removed from all routes.

Adding Event Marks

Event marks can also be added to the waypoint list. An event name is automatically created using the current date, and time, and is preceded with the letters EV.

To create an event mark, proceed as follows:

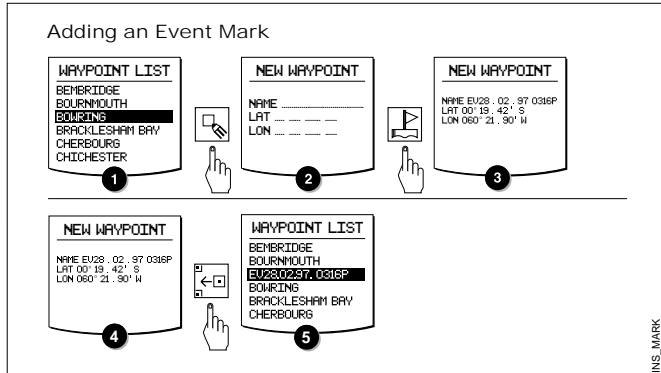

Route Page

The Route feature allows you to create, name and store up to 20 routes comprising of up to 50 waypoints from the waypoint list.

Creating a Route

Cycle the pages in the Navigate Chapter until 'ROUTE LIST' is displayed. To create a new route, follow the instructions below.

Creating a New Route

1 Press the up or down Navigator key to highlight any empty route.

2 Use these keys to enter data at the current cursor position (e.g. cycle of key 1 is 1, a, b, c, 1 etc.)

3 Enter a route name using the Navigator Keypad.

Use these keys to insert a space or delete data at the cursor position.

Use the multi-directional trackpad keys to move the cursor.

4 Press the up or down Navigator key to highlight the first waypoint entry (-01).



5 Now turn the page and add waypoints as shown

6

NEWRUITZ

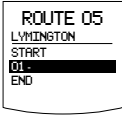
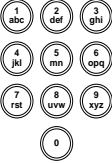
Adding Waypoints



1  **2**  Press the first character of the required waypoint name. The display will jump to the waypoint list which can be scrolled using the Navigator Keypad cursor keys (see below).

3   **Waypoint Scroll**
Press and hold the up or down Navigator key to scroll the list of waypoints.

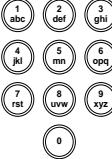

OR

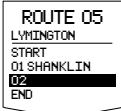
Waypoint Search
Use the Navigator keypad to type in the next character of the required waypoint. If there are multiple waypoints beginning with that letter, type in additional characters until the required waypoint name is highlighted.

4   Press this key to insert the highlighted waypoint to the route and return to the route contents display.

 Repeat the above actions from stage 2 above to add further waypoints to the route.

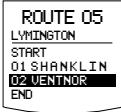
5   Once all the waypoints have been inserted, press the exit key to return to the route list display.



Deleting Waypoints from a Route

Cycle the Navigate Chapter until the 'Route List' is displayed.

Deleting a Waypoint from a Route

1 **ROUTE LIST**
02 CONES
03 CHERBOURG
04 DOVER
05 LYMINGTON E
06

Highlight the required route using the Navigator Keypad

2 **ROUTE LIST**
02 CONES
03 CHERBOURG
04 DOVER
05 LYMINGTON E
06

Press the delete key to display the 'Delete Waypoint?' pop-up.

3 **ROUTE 05**
LYMINGTON
START
01 SHANKLIN
02 UENTNOR
END

Highlight the waypoint to be deleted using the Navigator up or down key.

4 **ROUTE 05**
LYMINGTON
START
01 SHANKLIN
02 UENTNOR
END

Press the delete key to display the 'Delete Waypoint?' pop-up.

5 **ROUTE 05**
DELETE WAYPOINT?
END

Press to remove the selected waypoint from the route.

ROUTE 05
LYMINGTON
START
01 SHANKLIN
02 -
END

REMWP

What if I Decide that I Don't Want to Delete the Waypoint?

Providing you have not already deleted the waypoint, simply press the NO **X** key instead.

Press the exit **ESC** key to return to the 'Route List' page.

Inserting a Waypoint in a Route

Cycle the Navigate chapter until 'Route List' is displayed.

Inserting a Waypoint in a Route

1 Highlight the required route using the Navigator up or down key.

2 Press the 'Edit Route' key

3 Highlight the point at which you want to insert a waypoint using the Navigator Keypad up or down key.

4 Press the insert key to insert a new waypoint. A space for the waypoint will be created before the highlighted point.

5 Insert a waypoint from the Waypoint List as described in section 5.2 'Adding Waypoints'.

INSERTWP

Tracking to a Route Selected from the Route List

Cycle the navigate Chapter until the 'Route' page is displayed.

Selecting a Route

1

2 Use the up or down key to highlight the route you require.

3

4

5 Press the 'Track' key to begin tracking the selected route.

6

SELROUTE

Waypoint Advance

When a route is being tracked, you can advance to the next waypoint by selecting the 'Route' page and pressing  for 1 second.

Deselecting a Route

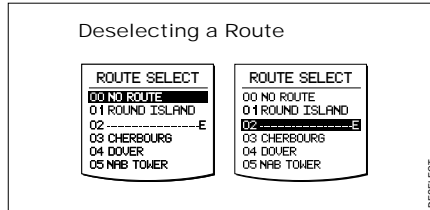

A route can be deselected by highlighting route '00' or an empty route (identified by the letter 'E').





Reversing the Direction of a Route

The direction of a route can be reversed so that you can make a return journey.

To reverse the direction of a route:

1. Go to the 'Route' page and go to 'Route Select'.
2. Select a route to be reversed using the Navigator up or down key.
3. Press  (reverse route key) – the letter 'R' appears to the right of the route name.
4. Press  (exit key) to return to the main route page – the letter 'R' appears in the top right of the screen to tell you that the route has been reversed.

Deleting a Route

1. Go to the 'Route List' page.
2. Highlight the route to be deleted and then press . The display now states 'DELETE ROUTE?'. To delete the route, press .
3. If you decide you don't want to delete the route, press .

Editing an Active Route

If the highlighted route is active, the letter 'A' is displayed adjacent to the route number.

If a target waypoint appears in the route contents list, the letter 'T' is displayed to the right of the name.

If the current route is the active route and the target waypoint is being tracked, waypoints before and including the target cannot be inserted or deleted. This prevents the current leg information changing while tracking.

Copying a Route to the 'External Route' Entry

Routes are stored in the memory of individual Masterview display heads. If you have linked a Navigator keypad to a specific Masterview display head, you will only be able to edit the routes stored in the memory of that display head.

The 'External Route' feature allows you to capture an active route, together with all the associated waypoints, and store a copy of it in the memory of another Masterview (with a Navigator keypad).

Active routes are automatically placed in the 'External Route' entry at the end of the 'Route List' display.

To copy an external route, please refer to the following flow chart.

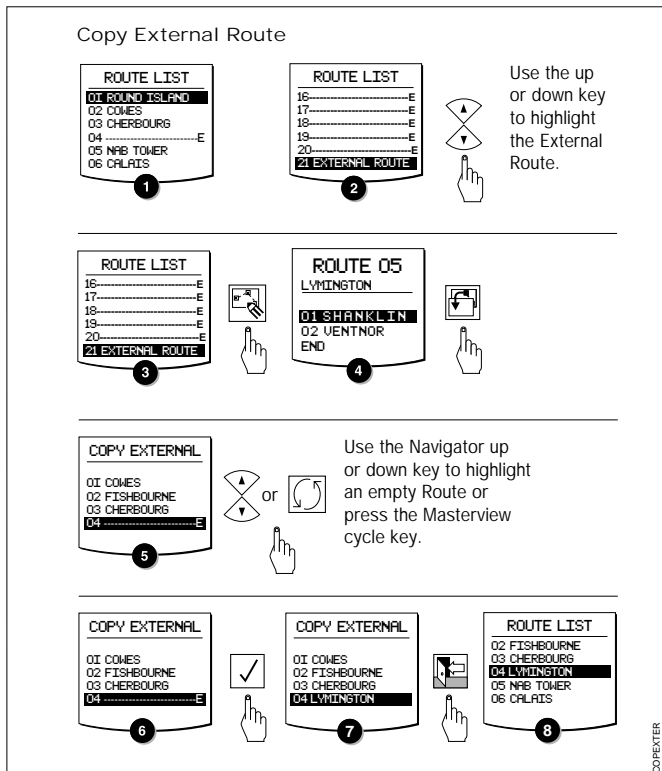

- If waypoints in the external route already exist, the old Lat/Lon is overwritten by the new (if different).

Capturing Single Waypoints

Go to a new route or insert a blank waypoint in an existing route.

A single waypoint will then be captured from other instruments (e.g. NavPlotter 100) and entered at the blank waypoint in the route and also placed in the Waypoint List.

General Route Information

If the currently displayed route has been selected from the route catalogue, the Masterview becomes the 'Navigation Master'.

If the currently displayed route has been received from SeaTalk, the Masterview becomes a 'Navigation Slave' – the second data line states "EXTERNAL".

If an 'R' is visible on the top line the route is in reverse order.

When you enter the Navigate chapter for the first time the Masterview displays the Route 'page'.

Note: Upon subsequent entries to the Navigate chapter, the page that was open when you left the Navigate chapter becomes the first page.

Once a route has been selected, the Route 'page' displays the currently selected route, whether it is active or not.

Operation in Dead-Reckoned Mode

If Lat/Lon data is not available, range and bearing and cross track error are calculated from a dead-reckoned position using boat speed and heading. The dead reckoned position is liable to significant errors and extra care must be taken to confirm actual position. Because of the potential for positional error, in dead-reckoned mode, cross track error is not transmitted onto SeaTalk and so autopilot track control is not possible.

Leg Information

This page displays information related to the legs of a journey (see below).

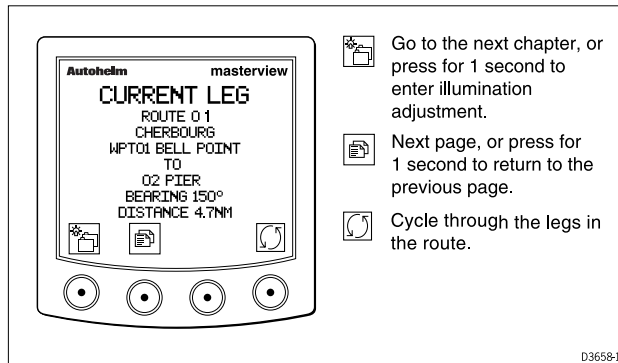

- If you are tracking a single waypoint or there is no current route, 'NO ROUTE' is displayed and the cycle key is disabled.

Single Waypoint Page

This page is used to display, create, and track a single destination waypoint using Lat/Lon or ranges and bearings and is designed to provide a quick method of entering a single waypoint as an alternative to using Waypoint List and Route Planning.



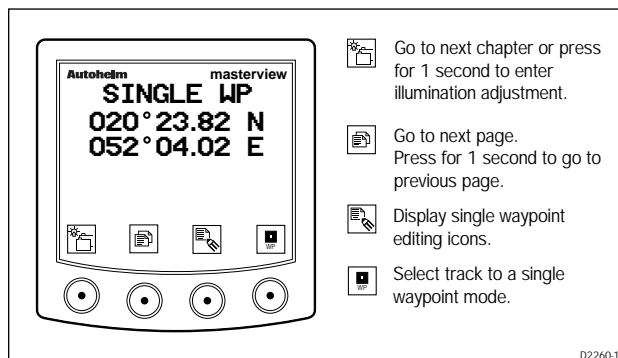

Note: If a pop-up message "TARGET WPT" or "TRACKING WPT" is displayed on this page, then an active waypoint exists via another source (Route page or another Masterview/ Navigator). This waypoint will need to be switched off before the Single Waypoint function can be used.

Creating a Single Destination Waypoint

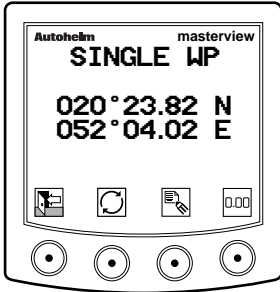

Select the edit icons to create a single destination waypoint.





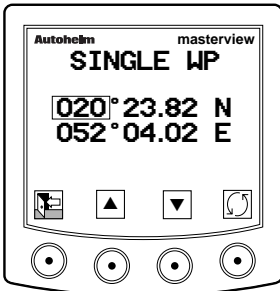

-  Return to main single waypoint display.
-  Switch between Lat/Lon and Range/Bearing.
-  Display icons for editing single waypoint data.
-  Press for 4 seconds to set the Lat/Lon to current position or reset Range/Bearing to zero.

D2261-1

Selecting a Field to Edit



-  Return to the single waypoint control page.
-  Reduce or change highlighted field.
-  Increase or change highlighted field.
-  Cycle fields (degrees, minutes, seconds, N/S/E/W).

D2262-1

- Bearings and ranges are edited in exactly the same way as Lat/Lon.

Note: A single destination waypoint can be imported from the waypoint bank as described earlier in this chapter.

Tracking to a Single Waypoint

The Masterview starts tracking once you have set the position (or bearing/range) for a single waypoint and returned to the main single waypoint display.

The following page is displayed if you are already tracking to a waypoint.

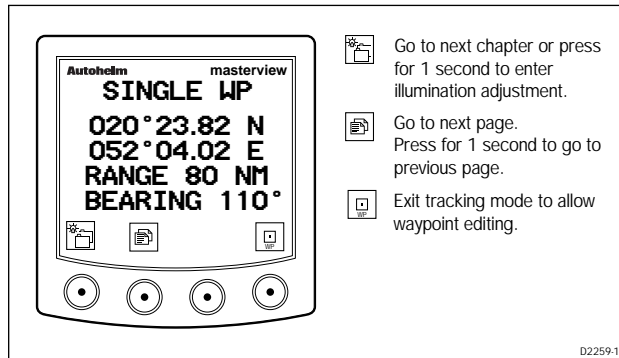

- The waypoint Lat/Lon, range and bearing is displayed when a single waypoint is being tracked.

Navigate Page





The navigate page displays any cross track error (in the log units selected during User Setup) and up to three lines from the following list:

- Speed (SPD)
- Velocity made good to waypoint (VMG)
- Speed over ground (SOG)
- Distance to waypoint (DTW)
- Estimated time to arrival (ETA)
- Heading (HDG)
- Course over ground (COG)
- Bearing to waypoint (BTW)
- Course to steer (CTS)

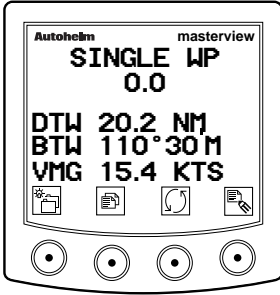
Selecting Lines

The default lines for this page are DTW, BTW and VMG. Alternative lines can be selected as follows:



-  Go to the next chapter or press for 1 second to enter illumination adjustment.
-  Next page or press for 1 second to return to the previous page.
-  Highlight another line.
-  Change contents of highlighted line. Press for 1 second to return to the previous selection.

D2263-1



Note: The highlight bar disappears after 8 seconds of keypad inactivity.

Steering Page

Cross Track Error

- This page displays any deviation (if applicable) from a planned route/track.
- A steering indicator shows the direction-to-steer to return to the planned route.



-  Go to the next chapter or press for 1 second to enter illumination adjustment.
-  Next page or press for 1 second to return to the previous page.
-  Select cross track error tramline.

D2264-1

Course Deviation Indicator (CDI)

- The CDI displays a graphic representation of your boat relative to the current destination waypoint.
- Bearing to waypoint and distance to waypoint information is displayed permanently.

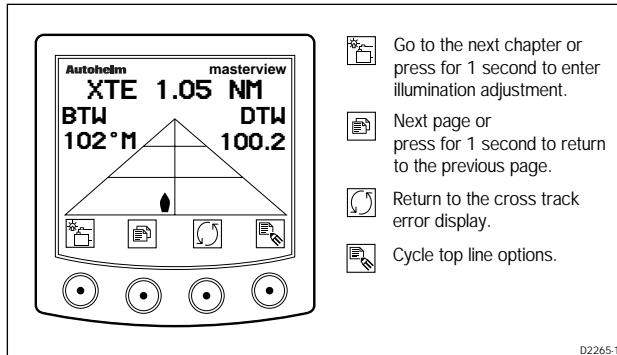

- The position of the boat symbol is proportional to cross track error. Additional information (cross track error (XTE) being the default) is displayed at the top of the screen. This can be changed to any one of the following:
 - Speed (SPD)
 - Velocity made good to waypoint (VMG)
 - Speed over ground (SOG)
 - Cross track error (XTE)
 - Distance to waypoint (DTW)
 - Estimated time to arrival (ETA)
 - Heading (HDG)
 - Course over ground (COG)
 - Waypoint number
 - Course to steer (CTS)

Selecting Lines

The default data line for the CDI is XTE. An alternative line can be selected using the right-hand key (as shown previously) to cycle the available sentences.

What if a Target Waypoint does not Exist?

The following “pop-up” is displayed if a target waypoint does not exist.

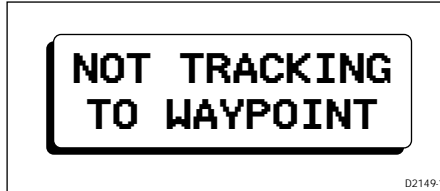

Position Page

SeaTalk Lat/Lon Data Available

This page displays your position and the current time, providing position data is available on SeaTalk.

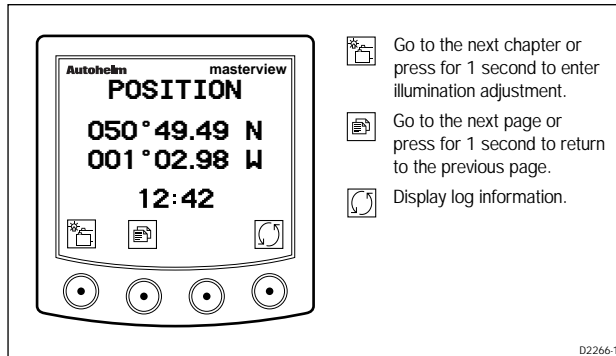



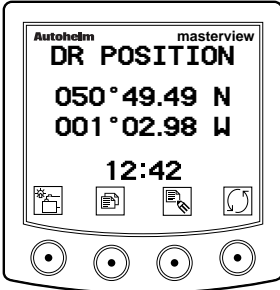

- The time field is replaced with dashes if time is not available.
- Time is displayed in the current system format.

No SeaTalk Lat/Lon Data Available

The current time and a dead reckoned position is displayed if SeaTalk position data is not available.







-  Go to the next chapter or press for 1 second to enter illumination adjustment.
-  Next page or press for 1 second to display previous page.
-  Show DR data and edit key icons.
-  Display log information.

D2267-1

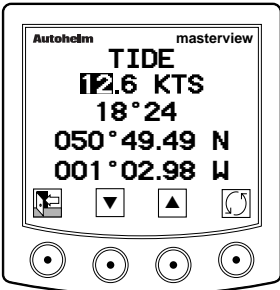
Dead Reckoning (DR) Control

The control page allows you to modify Dead Reckoned data.



-  Return to main display.
-  Decrease/change selected field.
-  Increase/change selected field.
-  Move between DR data fields.

D2268-1

Log Information

The log display shows your position (actual or dead-reckoned), time, course made good and distance made good.

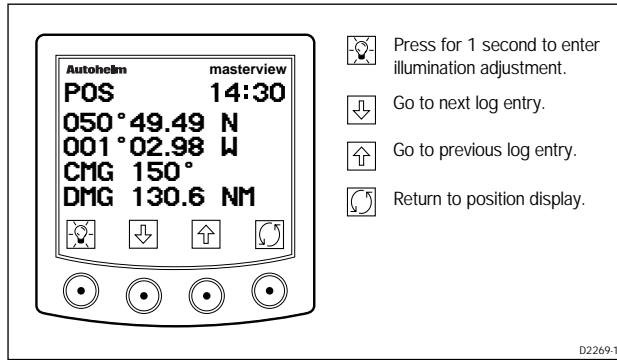

If you enter the log display and your position is dead-reckoned, the last recorded fix is displayed until a new fix has been logged (CMG and DMG are not displayed).

- Log entries are recorded every 30 minutes.
- Logged data (for the last 24 hours) is stored in memory and retained even when the system is powered down.
- The most recent data is always displayed.

The following page is displayed if there has been a Lat/Lon log entry in the last 24 hours.

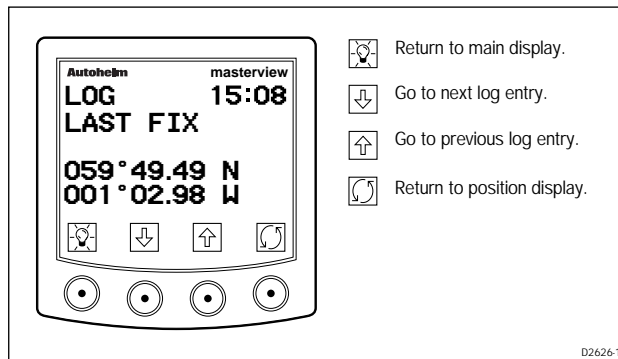





- The last Lat/Lon fix, and the time at which data was lost, is shown (CMG and DMG information is not displayed).
- This entry is removed when Lat/Lon data is restored.

General Page

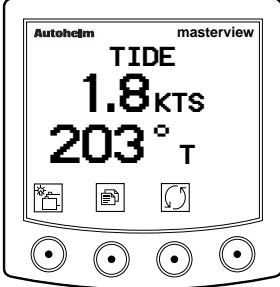
The general pages show calculated tidal information as well speed, heading, course over ground and speed over ground data.

Tide





-  Go to the next chapter or press for 1 second to enter illumination adjustment.
-  Go to the next page or press for 1 second to return to the previous page.
-  Display speed, heading, course over ground and speed over ground.

D2270-1

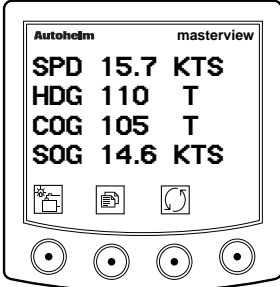
Speed, Heading, Course Over Ground, Speed Over Ground





-  Go to the next chapter or press for 1 second to enter adjust illumination.
-  Next page or press for 1 second to return to the previous page.
-  Display speed and heading.

D2271-1

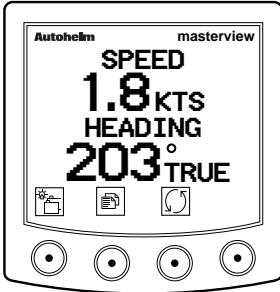
Speed and Heading





-  Go to the next chapter or press for 1 second to enter illumination adjustment.
-  Next page or press for 1 second to display previous page.
-  Display course over ground and speed over ground.

D2627-1

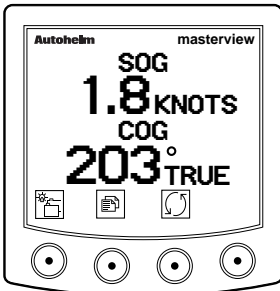
Speed Over Ground and Course Over Ground







-  Go to the next chapter or press for 1 second to enter illumination adjustment.
-  Go to the next page or press for 1 second to return to the previous page.
-  Return to the tide page.

D2628-1

Local Time

This page displays the local time and also allows you to set an alarm, and adjust the time. from two individual sub pages.



-  Go to the next chapter or press for 1 second to enter illumination adjustment.
-  Next page or press for 1 second to display previous page.
-  Press this key to go to the local time edit display.
-  Press to go to the alarm edit display.

D4138-1

Fix Status

The fix status page displays information related to GPS: satellites in use, satellites visible and HDOP.

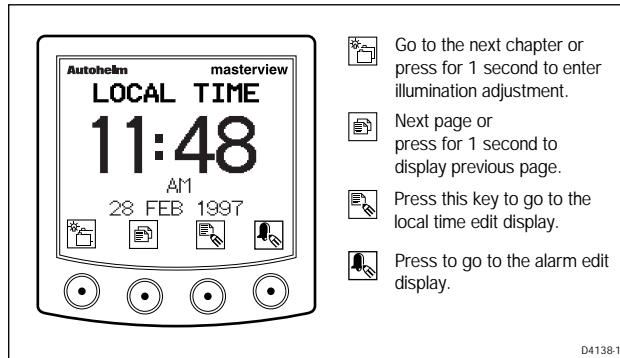

Pilot Chapter

The pilot chapter is designed for use with an autopilot keypad. This section covers the pages contained within the pilot chapter.

Note: Pilot functions (for example, auto and track modes) are described in the Autopilot Keypad manual.

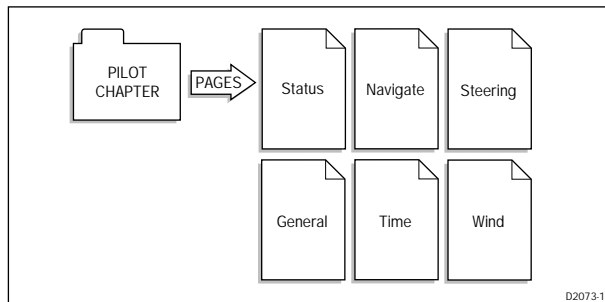

Status Page

The status page displays the following information:

- current autopilot status (auto, standby, vane, or track)
- a rudder angle indicator (with a scale from +40° to –40°)
- a heading indicator (true or magnetic).

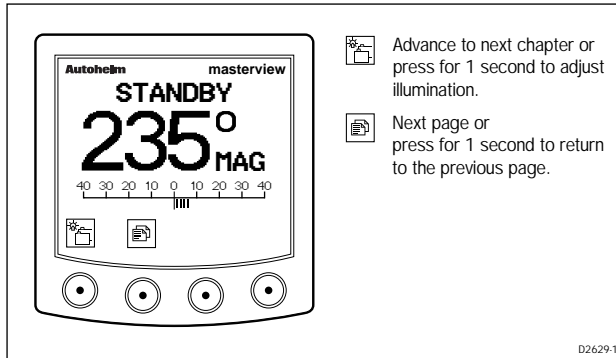

Navigate Page

This page displays information related to the current target waypoint.

The navigate page, by default, displays: DTW, BTW and VMG. Alternative lines can be selected as follows:

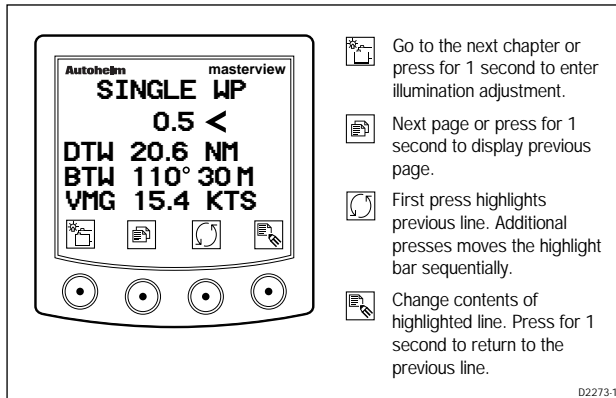

The navigate page also shows cross track error, a direction to steer indicator and up to three lines from the following list:

- Speed (SPD)
- Velocity made good to waypoint (VMG)
- Speed over ground (SOG)
- Distance to waypoint (DTW)
- Estimated time to arrival (ETA)
- Heading (HDG)
- Course over ground (COG)
- Bearing to waypoint (BTW)
- Course to steer (CTS)

Cross Track Error (XTE)

Cross track error is displayed in Statute Miles, Nautical Miles or Kilometres, depending on the units selected in User Setup.

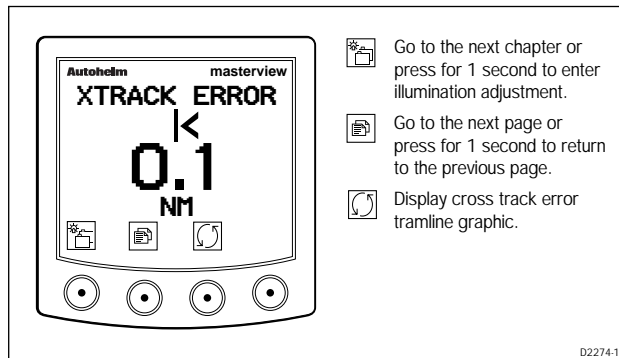

As with the navigate page, a direction-to-steer indicator shows the direction to steer to return to the correct track.

Course Deviation Indicator (CDI)

The CDI displays a graphic representation of your vessel relative to the current destination waypoint.

- Bearing to waypoint and distance to waypoint data is permanently displayed together with a boat symbol.
- The position of the boat is proportional to the cross track error value.

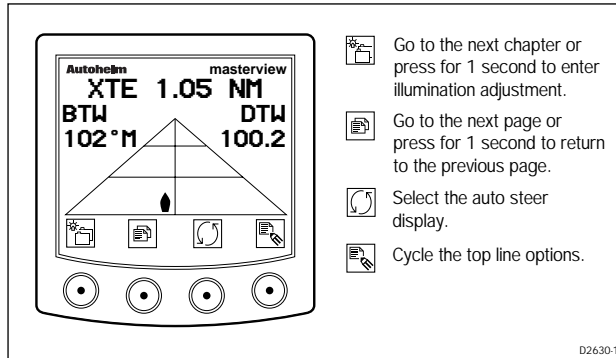

Additional information (cross track error being the default) is displayed at the top of the screen. This can be changed to any one of the following:

- Speed (SPD)
- Velocity made good to waypoint (VMG)
- Speed over ground (SOG)
- Distance to waypoint (DTW)
- Estimated time of arrival (ETA)
- Heading (HDG)
- Course over ground (COG)
- Waypoint number
- Course to steer (CTS)

What if a waypoint is not selected?

A “no waypoint selected” pop-up is displayed if a target waypoint has not been selected. Normal data fields are replaced by dashes and the right-hand keypad icon is removed.

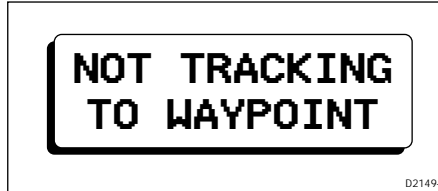

Auto Steer

This page displays the locked heading, a direction-to-steer indicator and any off course error.

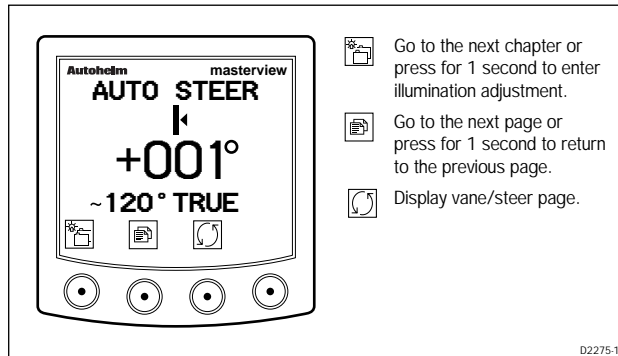

- This page is only available when the autopilot is in AUTO mode.
- This page is directly linked to the locked autopilot heading.
- There are basically two operating modes: current and fixed. Current displays the current autopilot heading (identified by a ~) together with a positive or negative autopilot heading error. Fixed mode displays the locked autopilot heading and a positive or negative autopilot heading error.

Vane Steer

Vane steer is linked to the autopilot locked wind angle. It is, therefore, only available when the autopilot is in VANE mode.

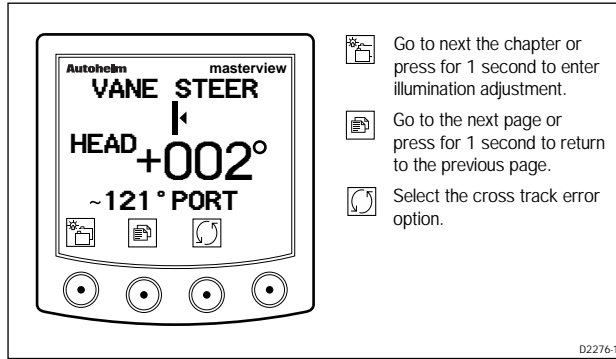

- This page shows wind direction changes relative to your current tack.
- Changes that allow you to maintain your current tack are indicated by the word “LIFT”. If the wind changes to the extent that you must change tack, the word “HEAD” is displayed.
- Any departure from the locked autopilot wind angle is shown in degrees, together with a direction to steer indicator to correct any error.

As with the auto steer mode, there are two operating configurations: current and fixed. These modes are selected in User Setup.



In current mode the current apparent wind angle (identified by a ~) is displayed at the bottom left of the LCD. In fixed mode the autopilot locked apparent wind angle is displayed.

General Page

Tide

This page displays calculated tide direction and tide speed.







-  Go to the next chapter or press for 1 second to enter illumination adjustment.
-  Go to the next page or press for 1 second to return to the previous page.
-  Display speed, heading, course over ground and speed over ground.

02270-1

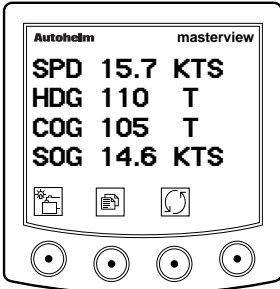
Speed, Heading, COG and SOG

The first screen displays (single-line format) your speed, heading, course over ground and speed over ground.



-  Go to the next chapter or press for 1 second to enter adjust illumination.
-  Next page or press for 1 second to return to the previous page.
-  Display speed and heading.

02271-1

Time

This page displays the current time (12 or 24 hour clock depending on your selection) and, if activated, the 4 minute watch alarm.

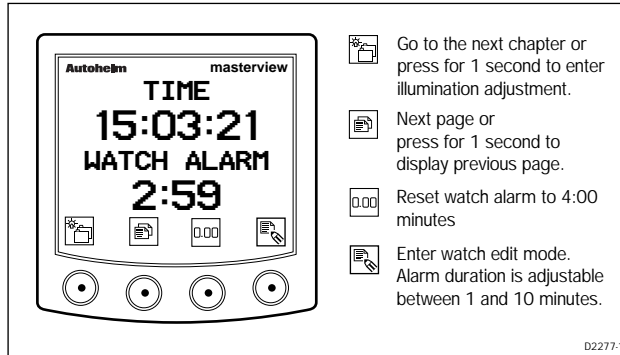

- The watch alarm counts down from 4 minutes to zero. The display flashes for 30 seconds when the timer reaches zero.
- If the **0.00** key is not pressed within this 1 minute period, all the alarms sound to warn your crew of a possible man-overboard situation that may have occurred within the last five minutes.
- The watch alarm is only active when the autopilot is operating in Auto Compass, Auto Vane or Auto Track mode.

Wind

The wind page is not available if you have selected power mode during User Setup.

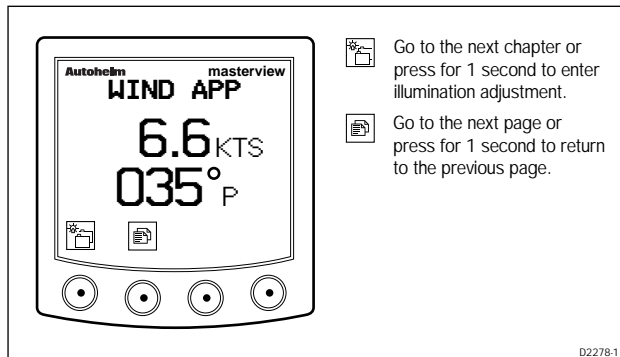

Pop-Up Pilot Chapter

The pilot pop-up chapter consists of displays that are only visible when the autopilot chapter is active.

If this chapter has been selected in User Setup, pop-up windows are displayed if the status of any of following items change.

- Response
- Rudder gain
- Track/Waypoint advance
- Status
- Course change
- Auto tack
- Old heading
- Old wind angle
- New heading
- New wind angle
- heading offset
- Compass adjust

For detailed descriptions of these features, please refer to User Setup.

Response

The response window is displayed when the autopilot transmits the current response level.

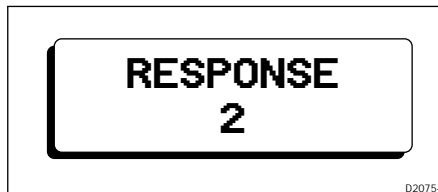

Rudder Gain

The rudder gain pop-up is displayed when the autopilot transmits the current rudder gain level.

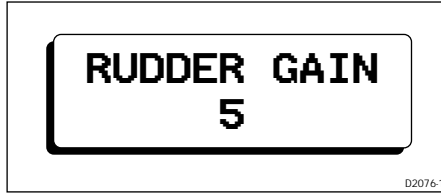

Autopilot Status

The status pop-up is displayed when the autopilot status changes (for example, standby to auto). This pop-up also displays your heading and the current rudder angle.

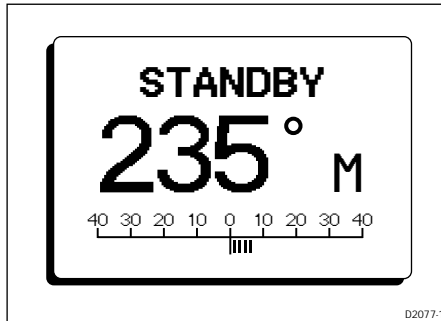

Course Change

This pop-up is displayed when the course change keys are used in auto mode.

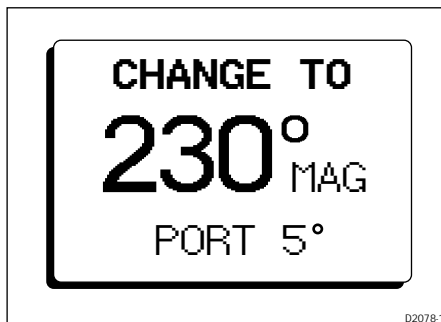

- The current locked autopilot heading is displayed in large characters.

- If the course change keys are used in auto mode, the most recent autopilot locked heading is stored as the old heading (providing course change keys have not been used within the last 20 seconds).
- If the autopilot is set to auto vane mode, operation of the course change keys results in the current wind angle being stored as the old autopilot wind datum prior to adjustment the current wind datum (providing the course change keys have not been used within the last 20 seconds).

Auto Tack

Starboard Tack

The starboard tack pop-up is displayed if a course change is made using autopilot keypad +1 or +10 keys.

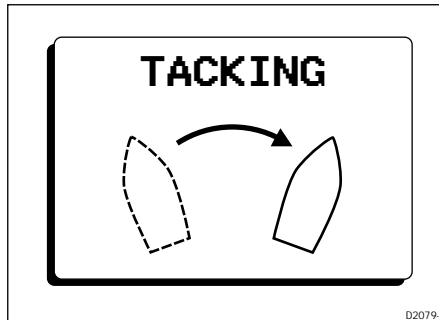

Port Tack

The port tack pop-up is displayed if a course change is made using autopilot keypad -1 or -10 keys.

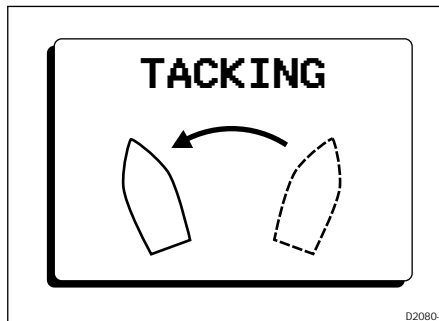

Check Tack

This pop-up is displayed if:

- A course change is made using autopilot keypad -1 or -10 keys when you are already on a port tack,
- A course change is made using the autopilot keypad +1 or +10 keys when you are already on a starboard tack.

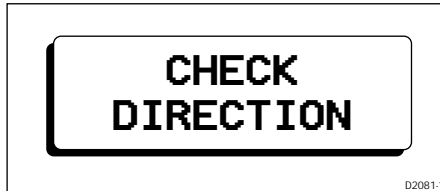

Caution: Although this pop-up warns you that you already on a particular tack, it will not stop a gybe.

Track and Waypoint Advance

A pop-up showing the next target waypoint number and bearing is displayed in response to a request for this data from the autopilot.

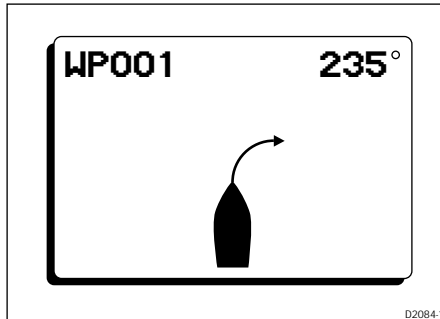

This pop-up alternates with the following display.

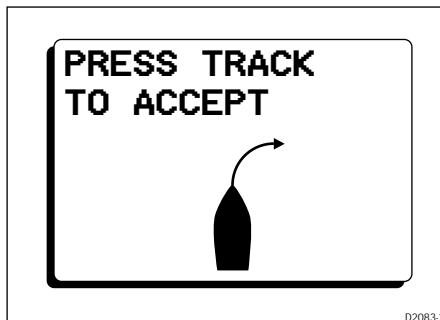

Old Heading

The old heading pop-up is displayed if you return to the previous (old) heading.

- A return to the previous (old) heading is achieved by pressing the autopilot keypad **AUTO** key for 1 second.

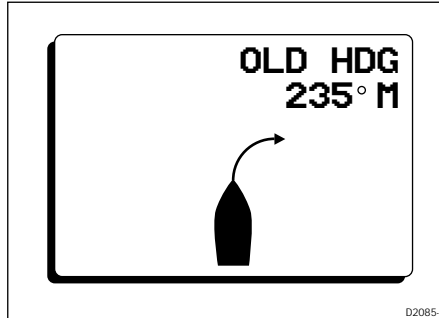

Old Wind Angle

This “pop-up” is displayed when the **STBY** and **AUTO** keys are pressed for 1 second.

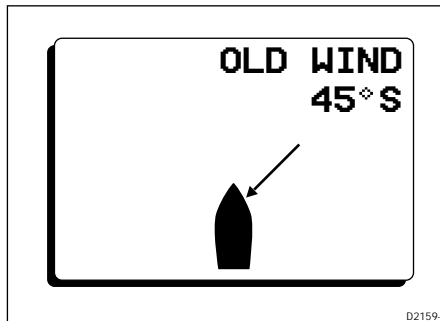

- The current wind angle is stored as the old autopilot wind datum.

Timers Chapter

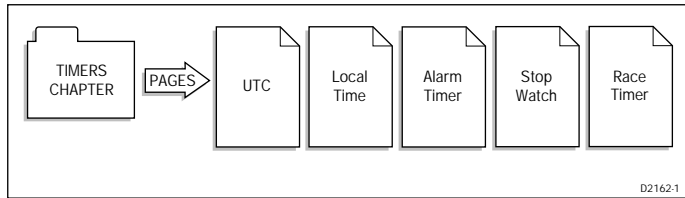

This chapter is used to display and edit the time, lap timers, split timers and the stopwatch.

UTC Page

This page displays the Universal Time Coordinate (Greenwich Mean Time) in 12 or 24 hour format.

Autohelm masterview

UTC TIME

06:03

AM

Go to the next chapter or press for 1 second to enter illumination adjustment.

Go to the next page or press for 1 second to return to the previous page.

D2279-1

Local Time Page

The local time page displays the local time and the date (European or US format).

Autohelm masterview

LOCAL TIME

18:03

06 SEP 95

Go to the next chapter or press for 1 second to enter illumination adjustment.

Go to the text page or press for 1 second to return to the previous page.





Open Local Alarm control page.

Display local time adjustment keys.

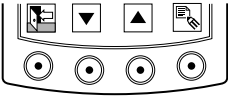
D2280-1

Modifying Local Time







-  Return to main local time page.
-  Decrease local time by 1 hour.
-  Increase local time by 1 hour.
-  Display format icons.

D2165-1

Changing the Format

- The time format can be set to the 12 or 24 hour clock.
- The date can be displayed in numbers or letters.
- The style can be US or European.







-  Return to local time adjustment.
-  Switch between the 12 and 24 hour format.
-  Switch between letter and number month formats.
-  Switch between American and European date formats.

D2166-1

Local Time Alarm Control

This feature allows you to set an alarm in the local time zone.



-  Return to the local time page.
-  Increase current field by 1 or switch to AM when AM/PM highlighted or switch alarm OFF when alarm ON/OFF is highlighted.
-  Decrease current field by 1 or switch to PM when AM/PM highlighted or switch alarm ON when alarm ON/OFF is highlighted.
-  Select next field. Sequence is hours, minutes, AM/PM, ON/OFF, hours.



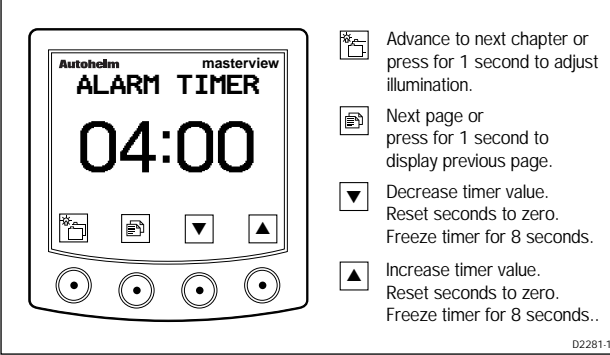

D2168-1

Alarm Timer Page

The alarm timer is used to set a countdown timer with a duration of 1 to 59 minutes.



02281-1

-  Advance to next chapter or press for 1 second to adjust illumination.
-  Next page or press for 1 second to display previous page.
-  Decrease timer value. Reset seconds to zero. Freeze timer for 8 seconds.
-  Increase timer value. Reset seconds to zero. Freeze timer for 8 seconds..



- An alarm sounds when the timer reaches zero.
- The adjustment keys may also be used to reset the seconds to zero.
- These keys may also be used to switch the timer off in the 1:00 to 0:00 minute range.

Stopwatch Page

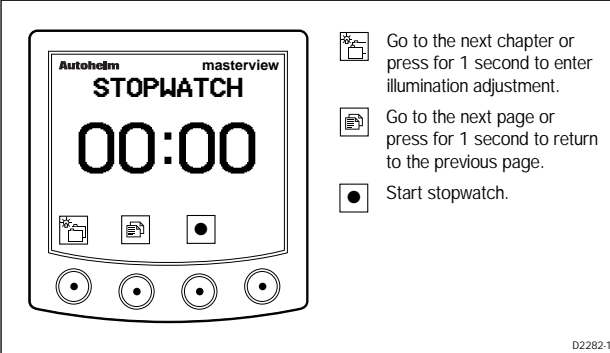
The stopwatch is used to record the time taken to complete an event.



02282-1

-  Go to the next chapter or press for 1 second to enter illumination adjustment.
-  Go to the next page or press for 1 second to return to the previous page.
-  Start stopwatch.

- The stopwatch is said to be in “standby” mode when it is not running.

Running Mode

When the stopwatch is running, the following functions can be accessed from the keypad.

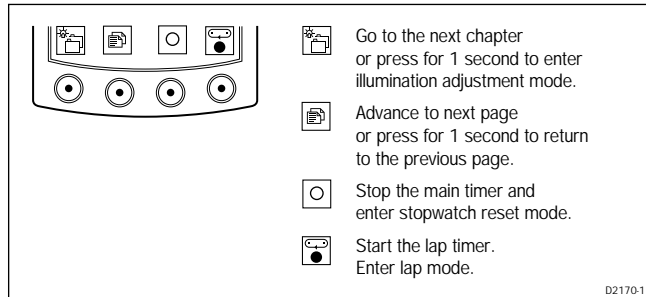

- The display shows hours, minutes and seconds (seconds are displayed in small characters) above 59 minutes and 59 seconds.
- The display enters stopwatch reset mode when the stopwatch is stopped.

Stopwatch Reset

When the stopwatch is stopped, the stopwatch may be reset by simply pressing the **0.00** key.



Lap Timer

The lap timer allows you to record the time taken to complete a lap.

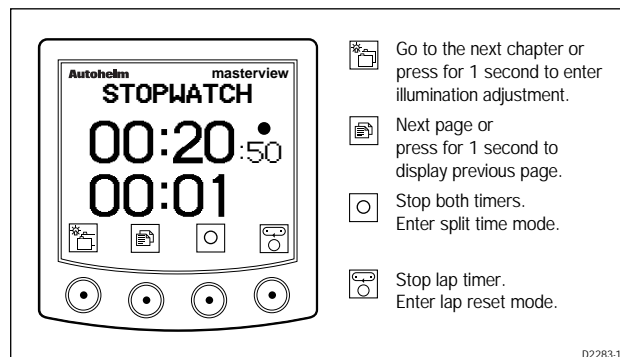
- The stopwatch is displayed at the top of the screen and the lap timer at the bottom.
- A flashing dot is displayed next to the stopwatch time if the main timer is running.



Resetting the Lap Timer

- Press the  key to reset the lap timer to “00:00”.
- The display returns to running mode when the lap timer is stopped.
- When the  key is pressed, the main timer stops, the lap timer resets to “00:00” and the stopwatch enters reset mode.

Split Time

Split time displays:

- The timer value (top) at the point of entry into lap mode.
- The value when both timers were stopped.

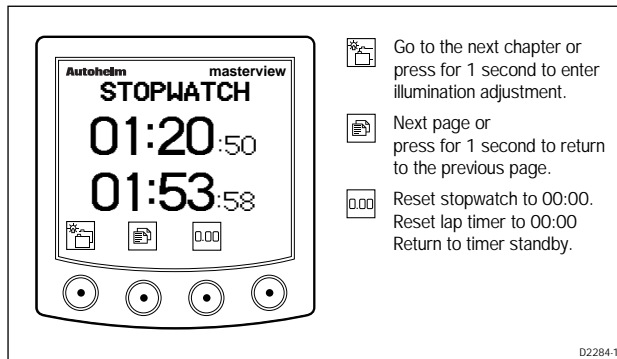

Starting Another Lap Time

Press the lap start key  to record another lap.

Race Timer

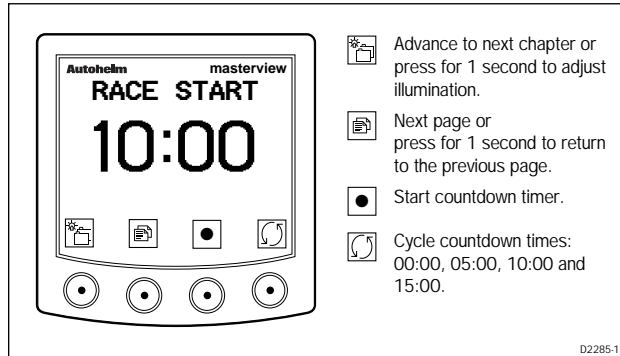

The race timer is used to set a race countdown or count-up timer. The timer settings available are: 5, 10 and 15 minutes (countdown timers) and zero (count-up timer).

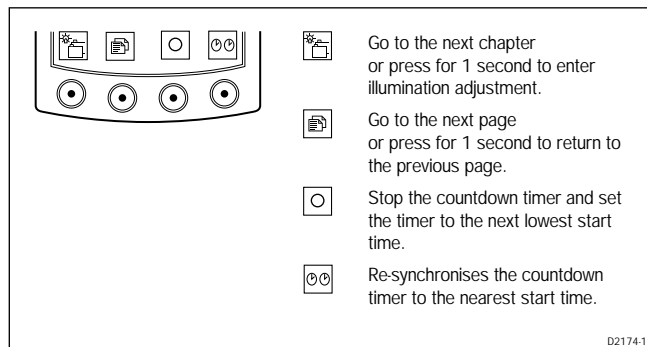

- The display head enters countdown or count-up mode when the start key is pressed (the unit is now the race timer “master”).

Countdown Mode





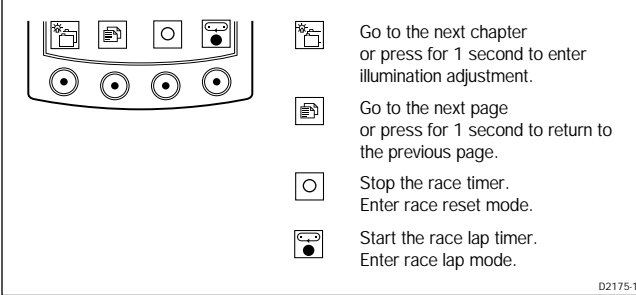

- The synchronise key () resets the timer to the nearest countdown timer.
- The synchronise icon is displayed 20 sec. either side of a start time.
- The stop key () is used to: stop the timer, reset the timer to the nearest lower timer value, and return the timer to race standby mode
- The timer enters race running mode when the 5, 10 or 15 minute countdown timers reach zero.

Count-up Timer (Race Running Mode)

The following functions may be accessed from the keypad when the race timer is running.



	Go to the next chapter or press for 1 second to enter illumination adjustment.
	Go to the next page or press for 1 second to return to the previous page.
	Stop the race timer. Enter race reset mode.
	Start the race lap timer. Enter race lap mode.

D2175-1

- The display shows hours, minutes and seconds (seconds are displayed in small characters) above 59 minutes and 59 seconds.
- The display enters race reset mode when the race timer is stopped.





Race Reset

Press the  key to reset the race timer (the display also returns to race standby mode).

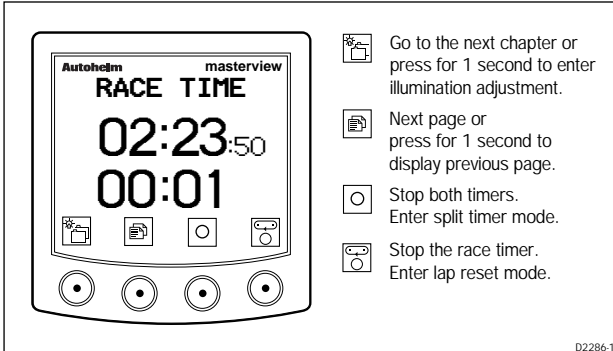
Race Lap Mode

In lap mode the race timer value is displayed at the top of the screen and the lap time at the bottom.





	Go to the next chapter or press for 1 second to enter illumination adjustment.
	Next page or press for 1 second to display previous page.
	Stop both timers. Enter split timer mode.
	Stop the race timer. Enter lap reset mode.

D2286-1

A flashing dot is displayed next to the stopwatch time if the main timer is running.

Lap Reset Mode

- Press the  key to reset the lap timer to “00:00” (the display returns to running mode).
- Reset mode is entered if the  key is pressed.

Split Race Time

This mode displays the timer value (top), the point of entry into lap mode and the value when both timers were stopped.

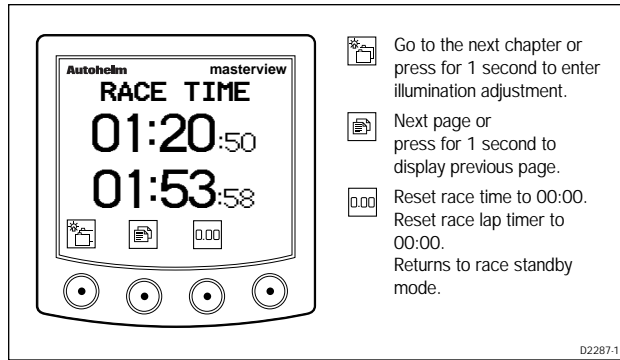

Note: As well as resetting both the race timer and lap timers, the  key also returns the display to race standby mode.

Environment Chapter

The environment chapter displays a history of:



- The system voltage.
- The temperature of the water.

SeaTalk Voltage Histogram

The histogram displays a graph of the supply voltage for a selected period of time.

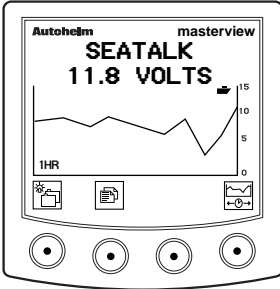
The time periods are 1 minute, 10 minutes, 1, 6 and 24 hours.







-  Go to the next chapter or press 1 second to enter illumination adjustment
-  Go to next page or press for 1 second to return to the previous page.
-  Select time scale for histogram 1min, 10min, 1hr, 6hr, 24hr.

D2288-1

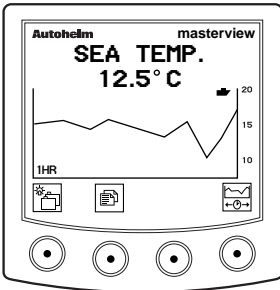
Sea Temperature Histogram

The histogram displays a graph of the sea temperature for a selected period of time.



-  Go to the next chapter or press 1 second to enter illumination adjustment.
-  Go to next page or press for 1 second to return to the previous page..
-  Select time scale for histogram 1min, 10min, 1hr, 6hr, 24hr.

D2289-1

Nav Status Chapter

The Nav Status chapter displays information related to the source of the position data.

Data Source Page

This page displays the source of the position data, eg. GPS.

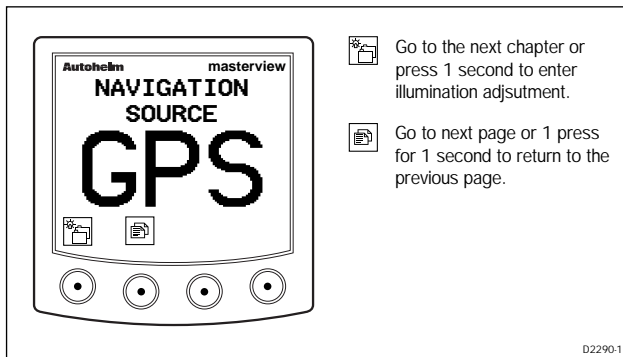



- The source selection key is not available if you are already tracking.
- “UNKNOWN” is displayed if GPS Lat/Lon data is the only data available.

Fix Status Page

The fix status page displays information related to the source of your position fixes. This information includes:

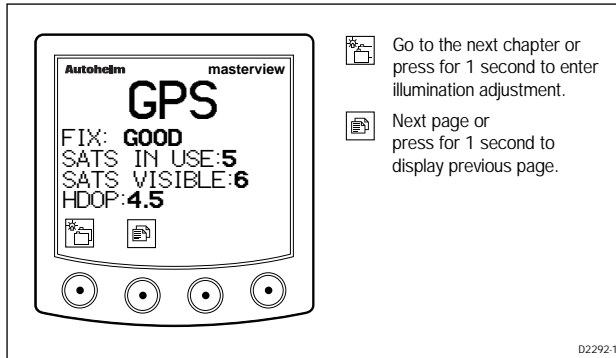
- Fix source: GPS
- Fix status: Good or Bad
- GPS only: satellites in use, number visible and the horizontal dilution of position (HDOP).



 Go to the next chapter or press for 1 second to enter illumination adjustment.

 Next page or press for 1 second to display previous page.

General Information Page

The general information page displays:

- GPS information (for example, 2D or 3D)
- The current datum (for example, WGS 84)
- The differential identification number (if applicable), for example, 4258.

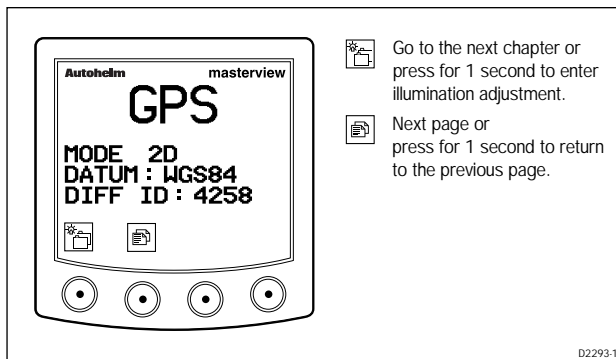

 Go to the next chapter or press for 1 second to enter illumination adjustment.

 Next page or press for 1 second to return to the previous page.

Satellite Plot Page

This page displays the position of the satellites relative to the earth and your boat.

- The satellite plot is always generated with true north uppermost.

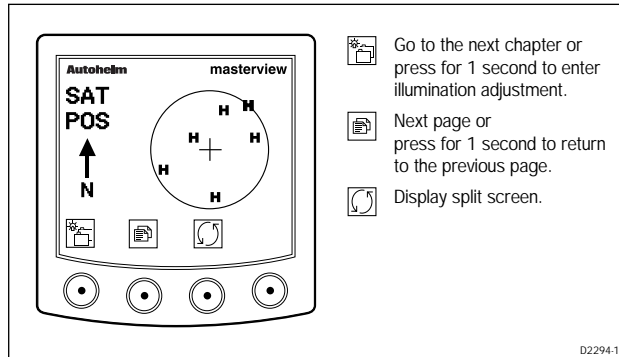

 Go to the next chapter or press for 1 second to enter illumination adjustment.

 Next page or press for 1 second to return to the previous page.

 Display split screen.

D2294-1

Split Screen Mode

The split screen displays the position of the satellites and data (satellite number, elevation, bearing, signal strength and status/search/track/demodulation) related to the currently selected satellite.

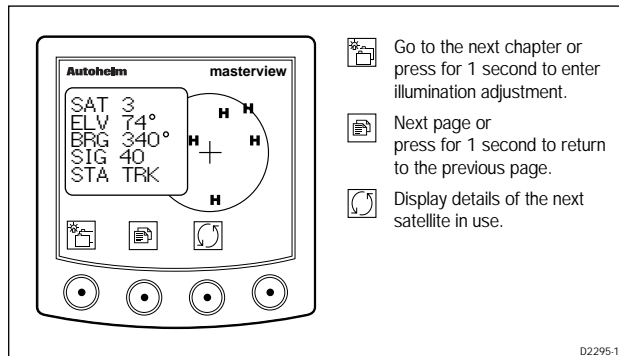

 Go to the next chapter or press for 1 second to enter illumination adjustment.

 Next page or press for 1 second to return to the previous page.

 Display details of the next satellite in use.

D2295-1

Note: The display reverts to the full screen plot page after 8 seconds of keypad inactivity.

Multiline Chapter





This chapter is used to configure the screen to display 2 or 3 lines of different data, for example, speed and depth or speed, depth and bearing to waypoint (BTW), and a maximum of 8 multiline pages.

The default page settings are:

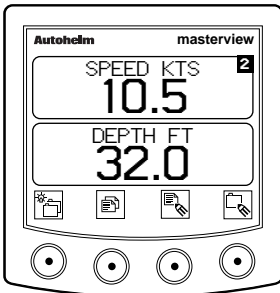
Page Number	Lines	Content
1	1	Speed
	2	Depth
2	1	Apparent wind angle
	2	Apparent wind speed
3	1	Current heading
	2	Locked heading
4	1	Course over ground (COG)
	2	Bearing to waypoint (BTW)
5	1	True wind angle
	2	True wind speed
	3	Tack course
6	1	Velocity made good (VMG) to waypoint
	2	Distance to waypoint (DTW)
	3	Estimated time of arrival (ETA)
7	1	Latitude
	2	Longitude
	3	Cross track error (XTE)
8	1	Local time
	2	Race timer
	3	Speed over ground (SOG)

Providing the edit chapters and pages option is checked in User Setup, the following features are available via the keypad.



-  Go to the next chapter or press for 1 second to enter illumination adjustment.
-  Next page or press for 1 second to return to the previous page.
-  Edit line mode.
-  Edit chapter mode.

D2296-1

Line Edit

Line edit allows you to change the line data displayed on each multiline page.

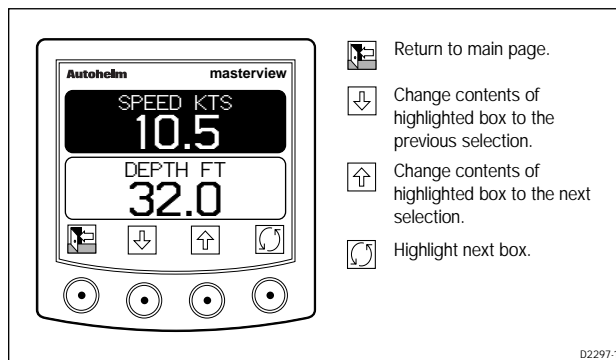

The next and previous keys are used to scroll the available data (listed below) for the highlighted line.

Line	Data	Line	Data
1	Boat speed	16	COG
2	Average speed	17	Tack course
3	Maximum speed	18	Waypoint number
4	SOG	19	BTW
5	VMG to waypoint	20	DTW
6	Depth	21	ETA
7	Minimum depth	22	XTE
8	True wind angle	23	Latitude
9	True wind speed	24	Longitude
10	Apparent wind angle	25	Local time
11	Apparent wind speed	26	Race timer
12	Beaufort	27	Tide speed
13	VMG to wind	28	Tide direction
14	Current heading	29	Rudder angle
15	Locked heading	30	Battery volts

Chapter Edit

Chapter edit is used to create or delete 2 or 3 line pages.

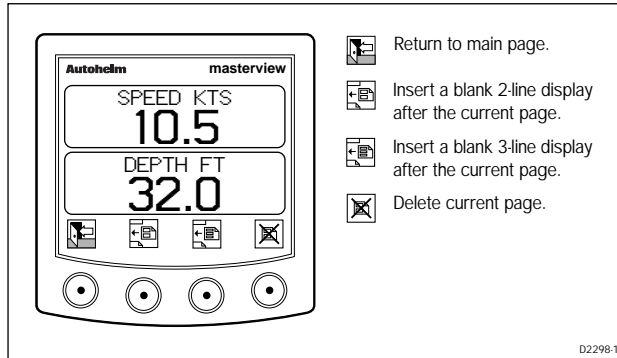

- New pages are inserted after the currently displayed page.
- The lines of a new page are blank – data must be added as described in the line edit section.
- The insert keys are not available when 8 pages are in use.
- The delete key is only active when there are two or more pages.

Maxiview Remote Chapter

The remote chapter is used to operate a Maxiview display head.

Note: Multiple Maxiview display heads should be grouped. Failure to group multiple units will result in all Maxiview heads operating at the same time. Please refer to the remote keypad User Setup section for grouping procedures.

Maxiview Remote Control Page

The chapter and page keys cycle the chapters and pages of a selected Maxiview display head.

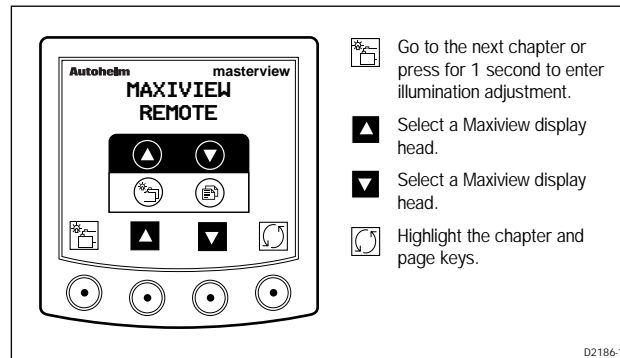
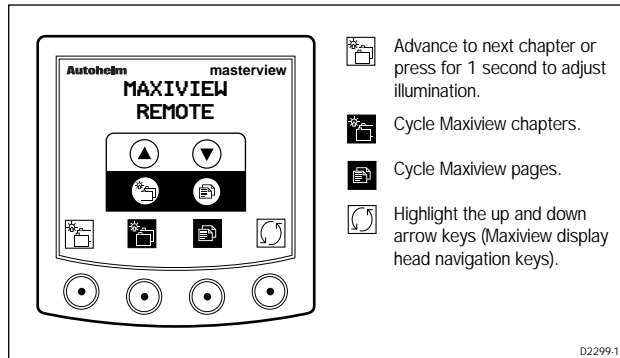

Illumination Selection and Adjustment

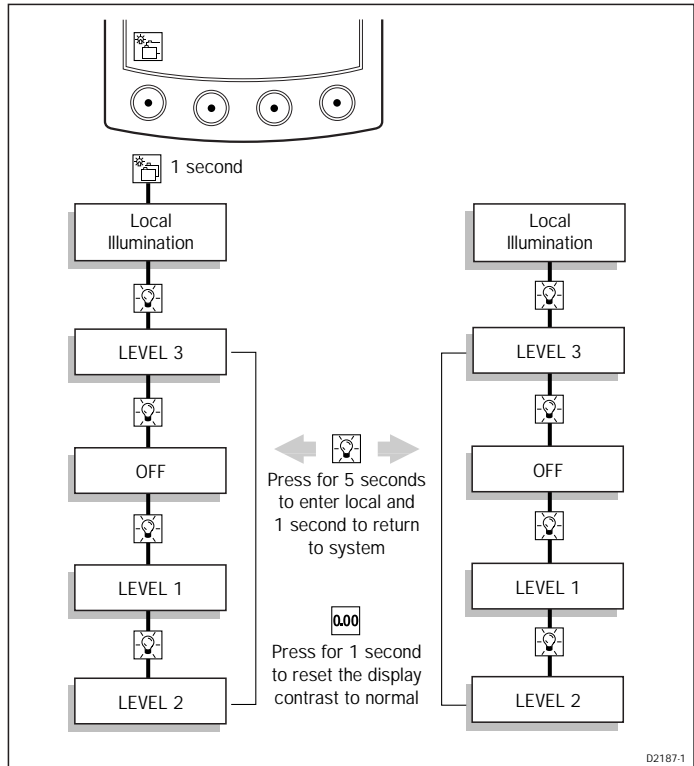

Local illumination sets the lighting for this display head only.

System illumination adjusts the lighting of all display heads in system illumination mode.

- The illumination display times-out to the normal operation after 8 seconds.
- Press any key to return to normal operation immediately.
- The keypad is always illuminated, even when the display illumination is off.

Alarms

Alarm Recognition

The Masterview can be set to respond to **all** alarms or just those identified as specific in *User Setup*.

Selection of “all” or “specific” is covered in *User Setup*.

Alarm	Alarm Displayed
Shallow Depth	SHALLOW WATER
Deep Depth	DEEP WATER
Anchor	ANCHOR ALARM
True Wind High Speed	TRUE WIND SPEED HIGH
True Wind Low Speed	TRUE WIND SPEED LOW
True Wind High Angle	TRUE WIND ANGLE HIGH
True Wind Low Angle	TRUE WIND ANGLE LOW
Apparent Wind High Speed	APPARENT WIND SPEED HIGH
Apparent Wind Low Speed	APPARENT WIND SPEED LOW
Apparent Wind High Angle	APPARENT WIND ANGLE HIGH
Apparent Wind Low Angle	APPARENT WIND ANGLE LOW
Manual Off-Course	OFF COURSE
ST80 Full Watch	WATCH PERIOD EXPIRED
MOB	Refer to the MOB section
Alarm Timer	Refer to the alarm timer section

- Each alarm can be defined as specifically ON or OFF by the user.

Recognised Autopilot Alarms

The following table lists alarms available when the pop-up pilot chapter is selected (refer to the User Setup chapter for selection details).

Alarm	Pop-Up Displayed	Specific
Drive Stopped	DRIVE STOPPED	YES
Off Course	PILOT OFF COURSE	YES
Waypoint Advance	WAYPOINT NO., NAME & BEARING	YES
Low Battery	LOW BATTERY	YES
Large XTE	LARGE XTE	YES
Wind Change	WIND CHANGE	YES
No NMEA Data	NO NMEA DATA	YES
NMEA Data Error	NMEA DATA ERROR	YES

- The Autopilot alarms cannot be cancelled from the Masterview.

These alarms can only be cancelled by:

- The autopilot.
- Waiting for the alarms to time-out.
- Using the autopilot keypad.

High Priority Alarms

Certain alarms are identified as high-priority. These are: drive stopped (autopilot), off-course (autopilot), manual off-course, shallow depth, ST80 Watch, waypoint advance and anchor alarm.

High priority alarms are handled in the following manner.

- A pop-up alarm is displayed providing you with a precise description of the alarm condition
- An audible alarm is also activated to accompany the visual alarm.
- With the exception of the pilot alarms, a “clear” icon is displayed to allow you to clear and silence the currently active alarm before the 8 second time-out.

Note: A silenced alarm is reactivated after 30 seconds and continues until the alarm condition no longer exists.

Identifying High Priority Audible Alarms

High priority alarms are identified by a continuous beep.

Low Priority Alarms

Alarms other than those described in the previous section are said to be low-priority.

When low-priority alarms are active the following occurs:

- All Masterviews flash alternately and the keypad icons are replaced with bells.
- An audible alarm sounds.
- Non-autopilot alarms are accompanied by a clear icon.
- The audible alarm can be cancelled by pressing any key – an alarm pop-up will then be displayed.

Identifying Low Priority Audible Alarms

Low priority alarms are identified by 3 long beeps followed by a 5 second break before a further 3 long beeps.

ST80 Watch Alarm

The watch alarm is designed to warn crew members of a possible man-overboard situation.

The watch alarm is a 4 minute timer that, once zero has been reached, sets-off audible and visual “Watch Expired” alarms. A full “Watch Alarm” is activated if the “Watch Expired” alarms are not cancelled within 30 seconds.

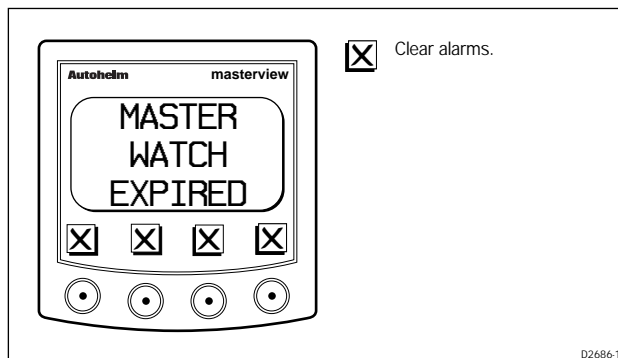

- The audible and pop-up alarms continue until cancelled.
- The watch alarm is only available when the pilot chapter is active.

Timer Alarm

The timer alarm is a low-priority local “alarm clock”. For details on how to set this alarm, please refer to the Timers section in the Operation chapter.

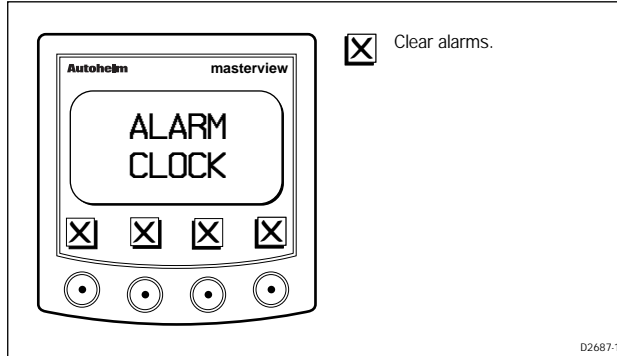

Man Overboard (MOB)

The MOB alarm is activated when a MOB condition exists as a result of operation of the MOB keypad or receipt of waypoint 999.

When a MOB alarm is active, the MOB page is displayed until the alarm is cancelled. You can press the chapter key to display other data as normal, however, the two right hand keys display the ‘MOB’ icons which can be pressed to return to the MOB screen.

Note: Each Masterview can be configured to ignore MOB alarms by switching off the MOB alarm in the ‘Specific Alarm’ list in Setup.

Dead Reckoned MOB Data (Default)

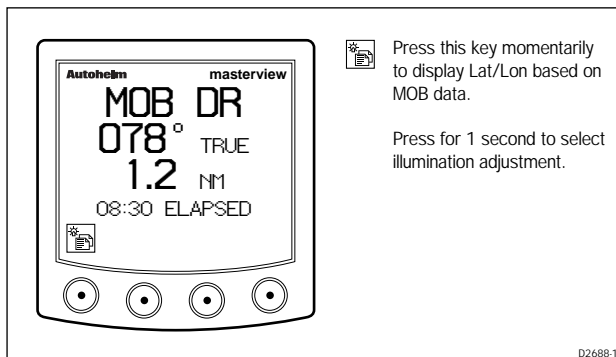

- The dead reckoned MOB page is displayed when valid dead-reckoned data is available.
- The elapsed time is shown in minutes and seconds. This field is filled with dashes if time data is not available .
- The range and bearing is from your boat to the person in the water.

Lat/Lon MOB Data

This display shows MOB data calculated using Lat/Lon. This display only appears upon entry to MOB when dead-reckoned data is not available.

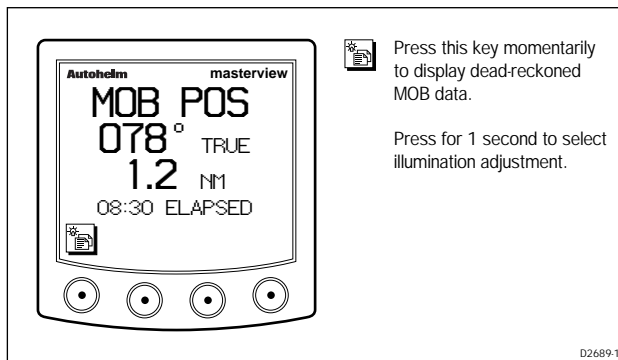

Waypoint 999

A waypoint with a "999" identifier is created if the man-overboard key is activated. The following screen is displayed if the only MOB data available is waypoint 999.

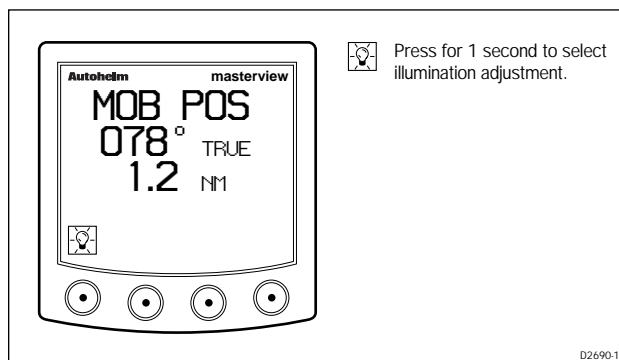

No Valid MOB Data

This screen is displayed if there is no valid data available during the MOB condition.

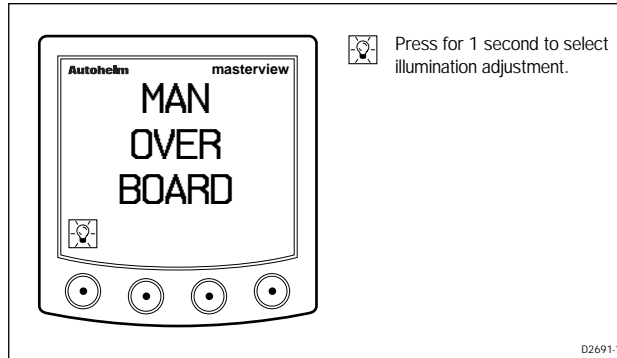

Audible MOB Alarm

The audible MOB alarm consists of three 1 second beeps followed by a 30 second break.

Keypad Handling

The Masterview can be used with the Navigator, Remote and Autopilot keypads.

Navigator Keypad

The Navigator keypad must be linked to a Masterview to access the extended features available using this keypad. Linking Navigator keypad's and Masterview display head's is covered in the User Setup chapter.

Remote Keypad

The remote keypad is used to mirror the Masterview key functions from a remote location. In order to mirror the keypad functions, Masterview display heads must be grouped to Remote Keypads.

The grouping procedure is covered in Remote keypad handbook.

Autopilot Keypad

When the Autopilot keypad is used with a Masterview with the autopilot chapters selected, the Masterview can be used as an autopilot control unit. Linking of the autopilot keypad and a Masterview is automatic.

Chapter 2: Setup

2.1 About this Chapter

This chapter describes how, using a combination of flow charts, diagrams and text, to set and adjust features contained in the User Setup menus.

These flow charts show the display roll-over for a particular key or key sequence. If a display is adjustable, related information follows the flow chart in the order of appearance.

2.2 Initial Start-up

When the Masterview is powered up for the first time you are presented with the “SELECT TYPE” display. Use this page to select your vessel type (sail or power).

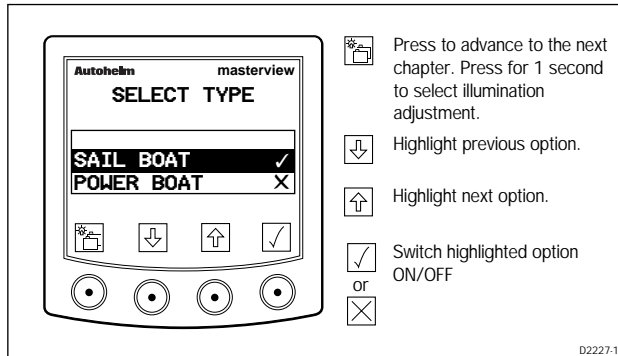

Points to remember...

- The selected mode is identified by a ✓.
- Deselected modes are identified by a ✗.
- The “SELECT TYPE” display defaults to “SAIL” if a permanent selection has not been made.
- Depending on your select type selection, the order in which the displays appear may differ from those in this chapter.

2.3 Entry into User Setup

You can enter User Setup from any page by pressing and holding the two left hand keys for 2 seconds.

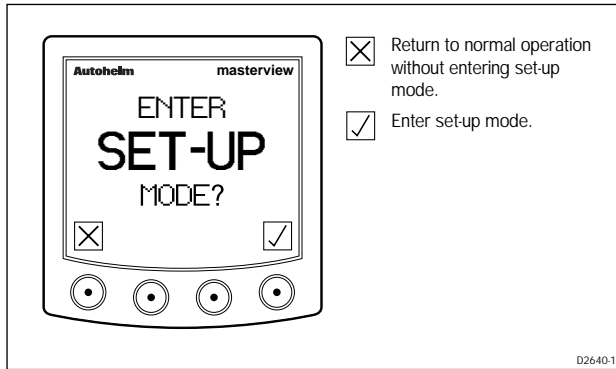
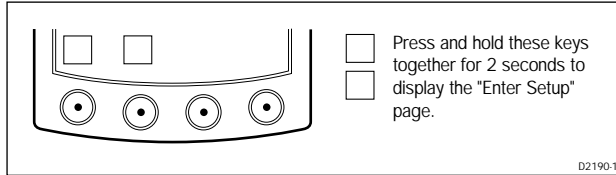

Note: Entry to "User Setup" has been prohibited if the display reads "SET-UP OFF". Contact your local dealer if this message is displayed.

2.4 Speed

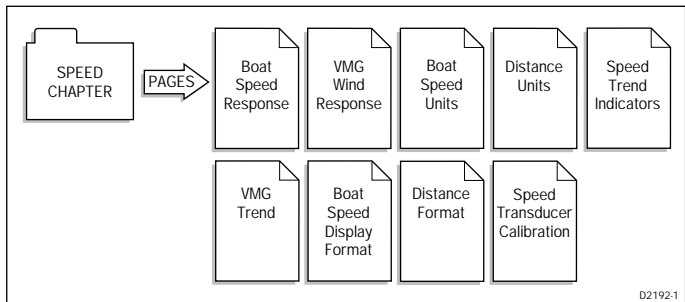

Boat Speed Response

This page is used to set the rate at which the displayed data is updated.

- The adjustment range is from 0 (greatest amount of damping) to 15 (least amount of damping).
- A high number provides a lively response and a low number a smooth response.

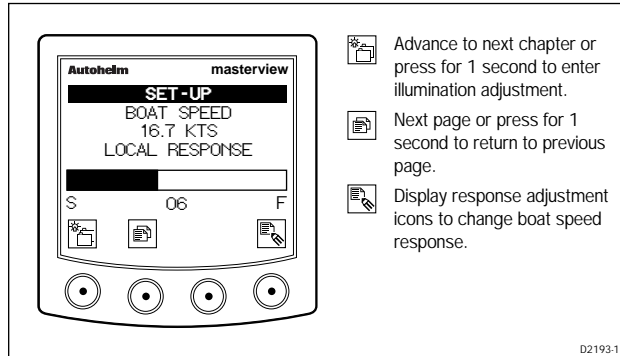

Adjusting Boat Speed Response

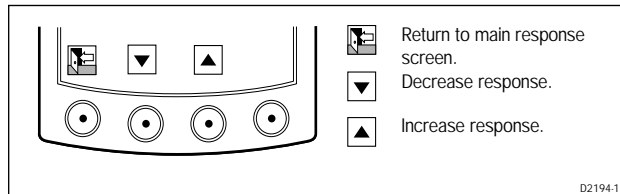

Boat speed response may be adjusted as follows.



- The response level only applies to the display head on which the adjustment is made.

VMG Wind Response





-  Advance to next chapter or press for 1 second to enter illumination adjustment.
-  Next page or press for 1 second to return to previous page.
-  Display response adjustment icons to change VMG response.

D2641-1

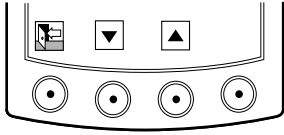
Adjusting the Response







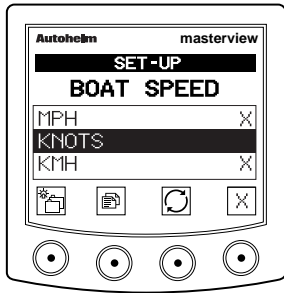

-  Return to main response screen.
-  Decrease response.
-  Increase response.

D2194-1

Boat Speed Units

The units for boat speed can be set to MPH, KTS or KPH. Upon entering the units display, the currently selected speed unit is displayed.



-  Advance to next chapter or press for 1 second to enter illumination adjustment.
-  Next page or press for 1 second to return to previous page.
-  Select alternative boat speed unit.
-  Turn highlighted unit off or...
-  Turn highlighted unit on.

D2195-1

- Units selection is not available if the active speed is not connected to SeaTalk.

Distance Units

The distance units can be set to KM, NM or SM. Upon entering the units display, the currently selected distance unit is displayed.

- Units selection is not available if the active speed is not connected to SeaTalk.

Selecting Distance Units

The distance units are selected in the same way as *Boat Speed Units*.

Speed Trend Indicators

Trend indicators show whether the boat speed is increasing or decreasing.

The threshold controlling these indicators can be adjusted as follows:

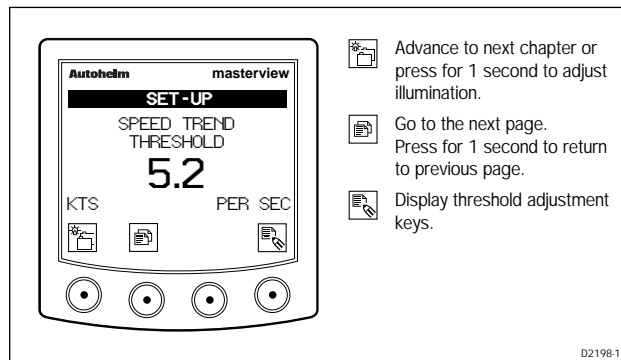

Adjusting the Current Trend Threshold

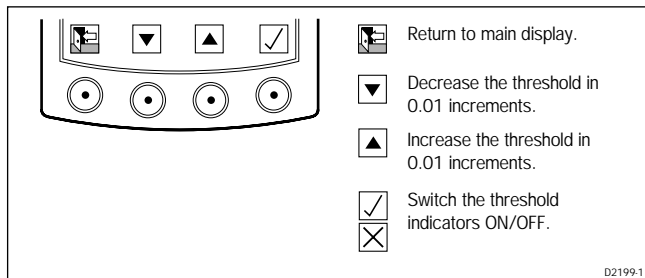

- The trend arrows are applicable to this display head only.
- The lower the setting the more sensitive the indicators are to change.

VMG Trend Indicators

The VMG trend indicators are adjusted in exactly the same manner as the speed trend indicators.

Speed Display Format

The format can be set to display the boat speed in one (X.X) or two (X.XX) decimal places.

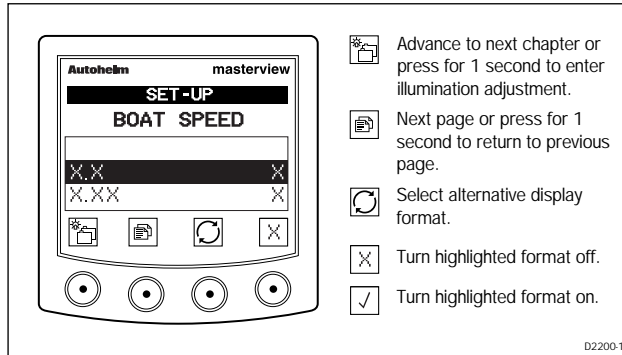

Distance Display Format

The format for distance is set in exactly the same way as the speed format.

Speed Transducer Calibration

The speed transducer must be calibrated to ensure correct speed and log values are displayed. There are three ways in which you can do this:

- **Auto:** Automatically record the correction factor after making 2 or more runs between the two charted objects.
- **Manual:** Manually key-in a correction factor. This is calculated after making two or more runs between two charted objects approximately 1NM apart (the average after 2 or more runs must be between 0.00 and 2.55).
- **GPS:** Match your actual speed with the speed over ground (SOG) sourced from GPS.



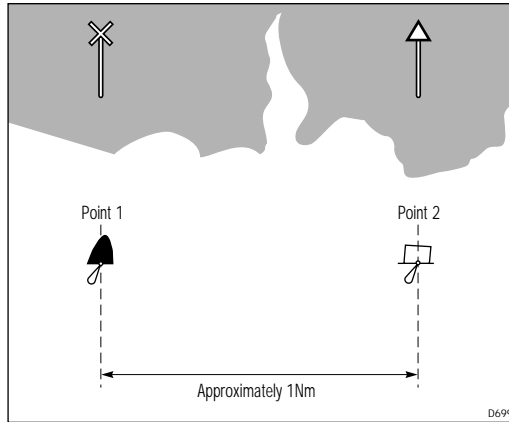

Recording a Correction Factor Automatically

Select two charted objects approximately 1 nm apart.

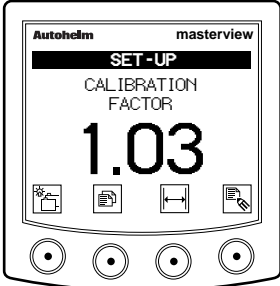

1. Select “auto calibration” using the  key.





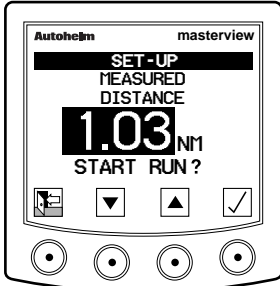

-  Advance to next chapter or press for 1 second to adjust illumination.
-  Go to the next page. Press for 1 second to return to previous page.
-  Activate auto calibration control page.
-  Display manual calibration icons.

D2202-1

2. Key in the distance between to the two chosen points (for example, 1.00NM) as shown in the following diagram.



-  Return to main display.
-  Decrease the measured distance.
-  Increase the measured distance.
-  Start a run.

D2203-1

3. Press and then sail or motor from “point 1” to “point 2”.

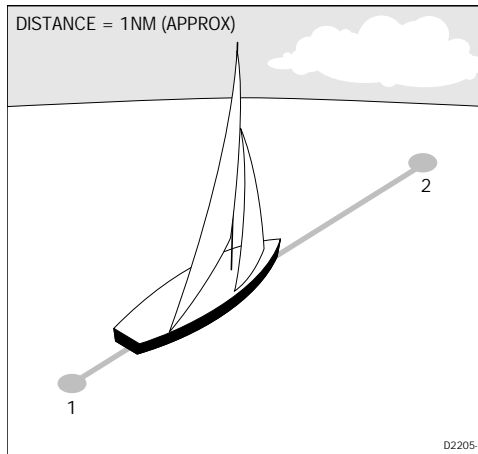

4. When you arrive at point 2 press . Providing the logged distance is within the acceptable range, the following “pop-up” is displayed.

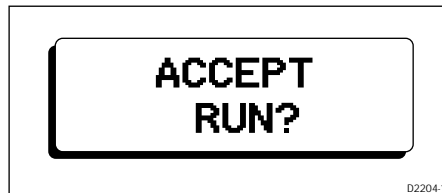

Note: A run may be cancelled by pressing the key — the message “INVALID RUN, CHECK TRANSDUCER” is displayed. You must then press to advance to the “return run” display (action 6).

5. Press to accept the first run — “RETURN RUN?” is now displayed.

Note: If you want to cancel the calibration procedure at this stage, press to return to the “calibration factor” page.

6. Press and then sail or motor from “point 2” to “point 1”.

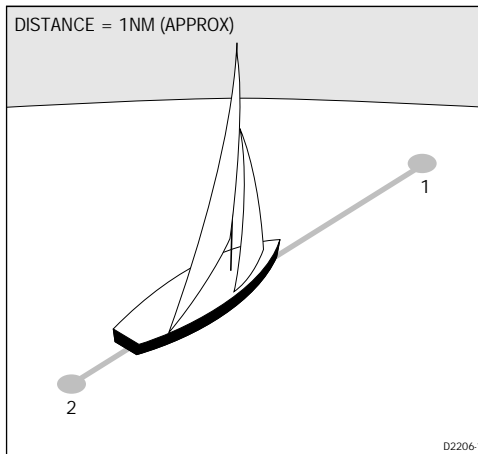

7. When you arrive at point 2 press . The displays now reads “ANOTHER RUN?” — you now have the option to complete another run.
8. Once you have completed as many runs as you require, press to return to the “calibration factor page”.

Caution: Logged data will be lost if you exit log calibration using the key.

9. Calibration is now complete and the calibration factor has been automatically calculated and stored.

Manually Recording and Entering a Calibration Factor

With the log display active, sail or motor from point 1 to point 2 and make a note of the recorded distance.

Now go from point 2 to point 1. Once again make a note of the recorded distance.

The sum of the two distances should now be divided by 2 to give an average. This average should now be divided by the actual distance to give you the calibration factor. Enter this factor as follows:

1. Go to the “Calibration Factor” page.

2. Press the  key to display the following icons.

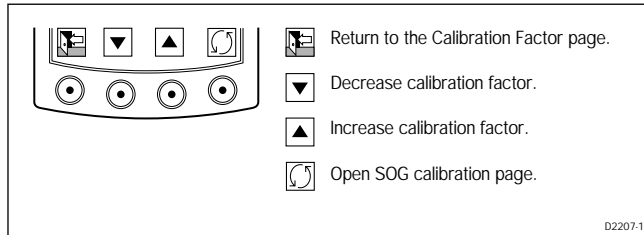

3. Enter the calculated factor (between 0.10 and 2.55) as shown.
4. Exit and return to the main “Calibration Factor” page.

Calibrating using Speed Over Ground (SOG)

This method allows you to calibrate the speed transducer by matching your boat speed with the speed over ground (sourced from GPS).

To calibrate the transducer in this way, pick a calm day with very little tide.

1. Go to the “Calibration Factor” page.
2. Press  to display the following key icons.

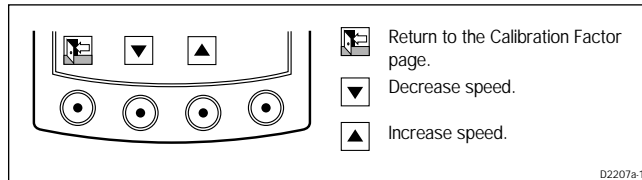

3. Press the key assigned to the speed over ground feature to display your boat speed and the speed over ground.
4. Maintaining a steady course, adjust the boat speed display, using the up and down keys, so that it matches the speed over ground.
5. Calibration of the speed transducer is now complete. Now press exit to return to the “Speed Transducer Calibration Page”.

2.5 Depth

This chapter describes how to calibrate the depth transducer for use with both power and sailing vessels. The pages contained in this chapter are:

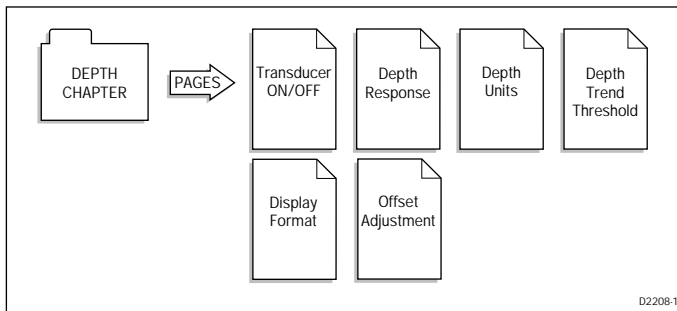

Switching the Transducer ON and OFF

The depth transducer can be switched ON or OFF as required. This is useful if you already have a fishfinder and the operating frequency is the same as the ST80 depth transducer.

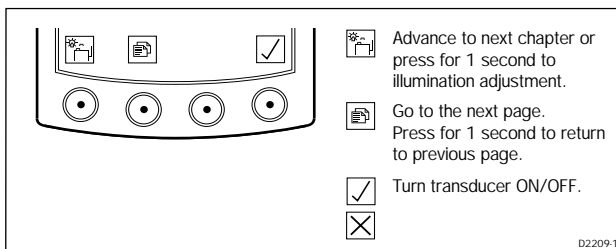

Note: SeaTalk sentences are not generated unless setup data is requested when the transducer is off.

Response Page

Depth response adjustments are made in exactly the same way as described in the speed setup chapter. Once again 0 is the greatest amount of damping and 15 the least.

Depth Units Page

The depth units can be set to FT (feet), M (metres) or FA (fathoms). Upon entering the units display, the currently selected units are displayed.

- Units selection is not available if the active depth is not connected to SeaTalk.

Selecting Depth Units

Refer to the speed chapter for selection details.

Trend Indicators Page

These indicators are used to show whether the trend is towards increasing or decreasing depth. Please refer to the speed setup chapter for adjustment details.

Note: The trend arrows are applicable to this display head only.

Depth Display Format

The format can be set to display the depth to one (X.X) or two (X.XX) decimal places.

Note: The current units are identified by a ✓.

Depth Offset Page

There are two settings for depth offset: keel or waterline.

- Keel offset is the distance from the transducer to the bottom of the keel.
- A waterline offset is measured from the transducer to the surface of the water.

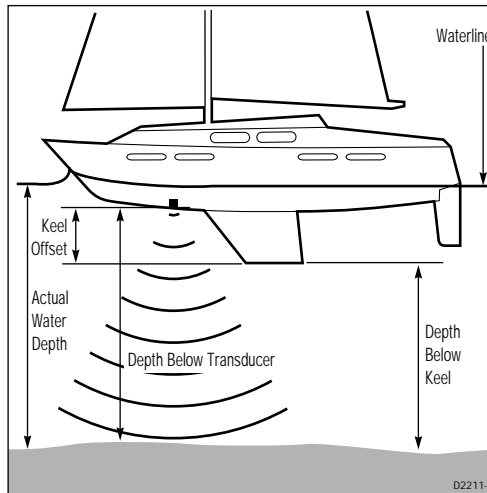

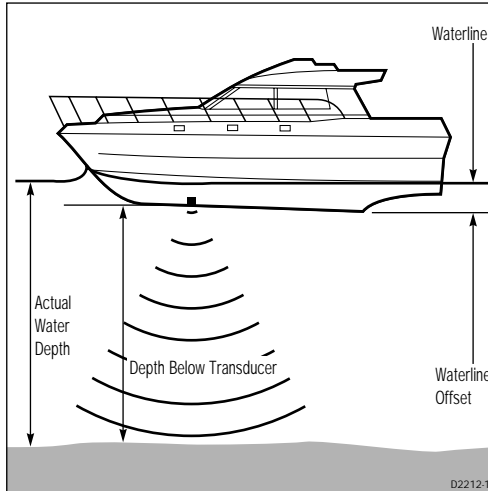

Entry to offset adjustment is made using the right-hand key (as shown in the following diagram).

Autohelm masterview
SET - UP
KEEL OFFSET
-3.0 FT

- Advance to next chapter or press for 1 second to enter illumination adjustment.
- Next page or press for 1 second to return to previous page.
- Display offset adjustment icons.

D2302-1

Autohelm masterview
SET - UP
WLINE OFFSET
+4.5 FT

- Advance to next chapter or press for 1 second to adjust illumination.
- Next page or press for 1 second to return to previous page.
- Display offset adjustment key icons.

D2303-1

Setting the Offset

Use the up or down key to set the required keel or water line offset (the range is from -10 to +10ft).

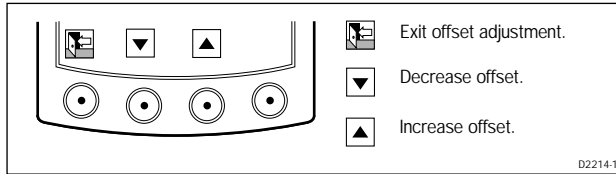

2.6 Wind

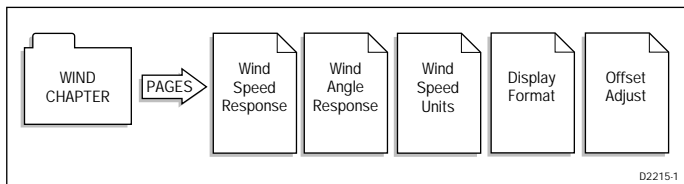

Wind Speed & Angle Response, Wind Speed Units & Display Format

Adjustment procedures for wind speed, wind angle response, wind speed units and display format are identical to those provided in the speed section.

Wind Speed Units

- The units for wind speed can be set to knots (KTS) or metres per second (MS).
- The currently selected units are displayed upon entry to this page.
- The wind speed units are transmitted system-wide on SeaTalk.

Wind Angle Offset Page

This page displays the offset (port or starboard) entered when aligning the wind transducer to your boat.

Note: On initial entry to this page the offset reads "0" and the wind angle is the current wind angle (the current wind may or may not be accurate at this stage, hence the wind angle offset procedure).

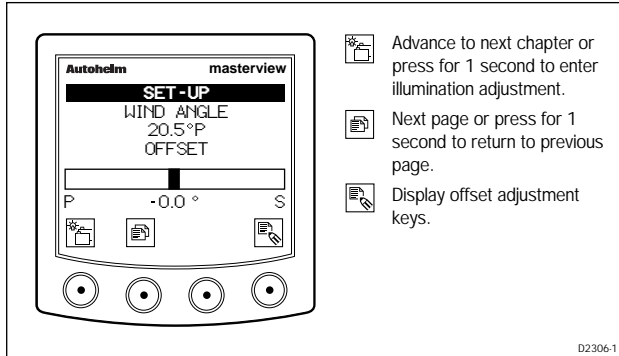

Procedure

1. Press the right hand key to display the offset adjustment icons.

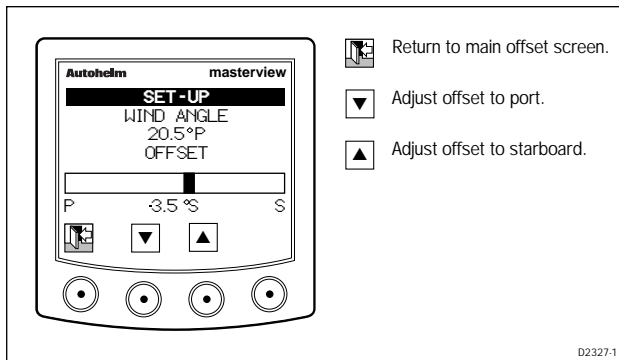

2. Motor directly into the wind.

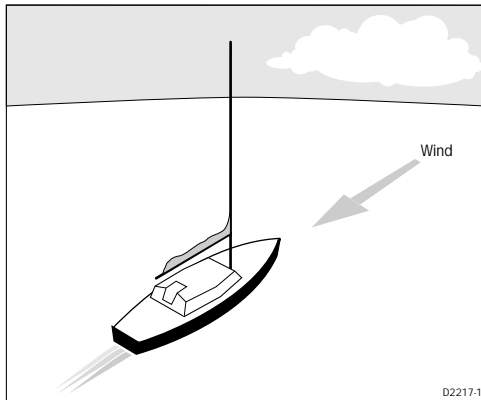

3. Use the up and down keys to set wind angle (displayed above the adjustment bar) to zero. As the wind angle is zeroed the actual offset (port or starboard) is displayed below the adjustment bar.
4. Wind angle offset adjustment is now complete. Press EXIT to return to the main wind angle offset page.

2.7 Heading

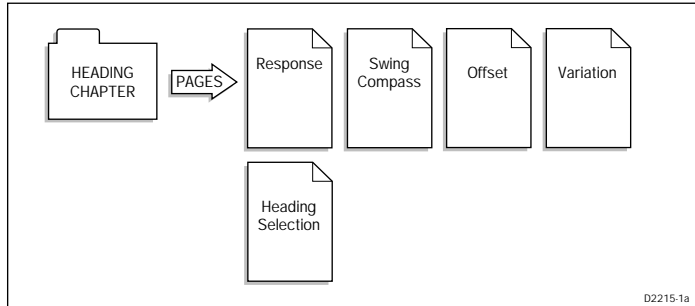

Heading Response

Heading response controls the rate at which heading information is updated.

- Advance to the next chapter or press for 1 second to enter illumination adjustment.
- Go to the Next page or press for 1 second to return to the previous page.
- Display adjustment icons.

D2307-1a

Response Adjustment

- Exit response adjustment.
- Decrease response.
- Increase response.

D2214-1a

- The adjustment range is from 0 to 15.
- The lower the range value the slower the update.

Compass Linearisation

Compass linearisation corrects (compensates) the active compass for deviation caused by large iron masses (for example, the engine, keel, fittings made of ferrous metals and other electrical equipment).

To linearise the compass you must turn your vessel in slow circles until sufficient information has been logged to provide deviation data.

Procedure

1. At the deviation display, press the right-hand key to start the linearisation procedure (the display now says “TURN BOAT SLOWLY”).



2. Start turning your vessel in slow circles with a boat speed of at least 2 knots. Keep turning your vessel in circles until a deviation value is displayed.
- If the rate at which you are turning your vessel is too high, “TURN RATE TOO HIGH” is displayed.

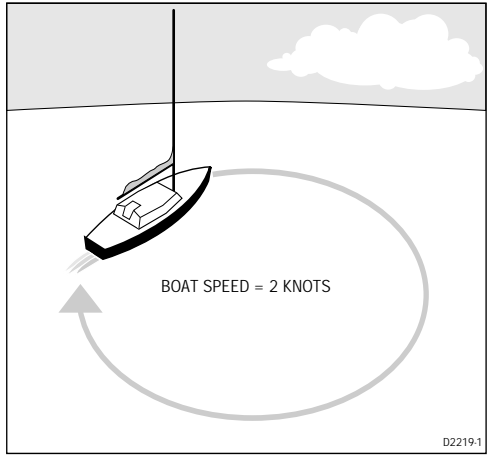

- 3. Linearisation is now complete

Compass Offset Page

Once the compass has been linearised, the displayed heading must be matched to a known transit bearing.

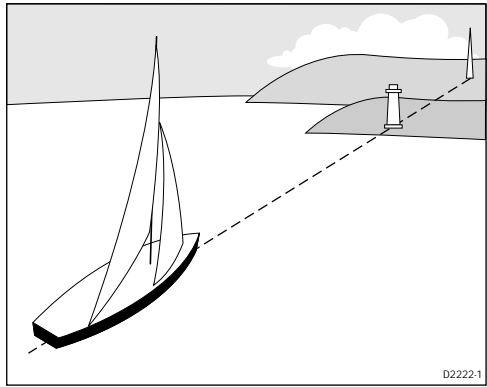

The main offset page displays your current heading and the heading offset value.

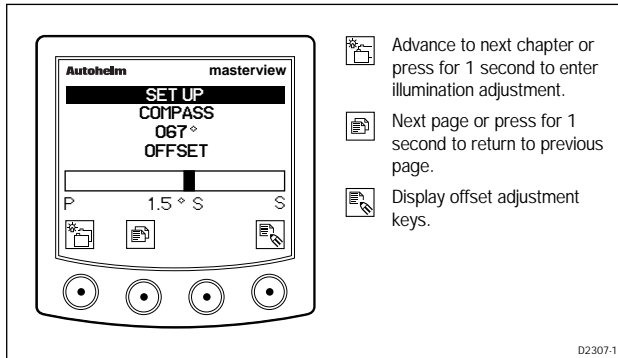

Adjusting the Offset

Press the right hand key to display the offset adjustment icons.

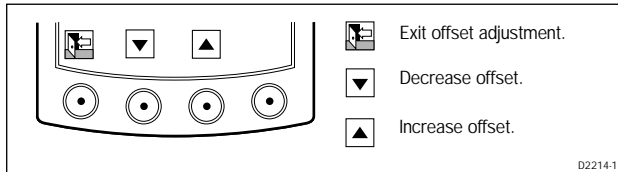

Use the up and down keys to adjust the offset to match the transit. On completion, press EXIT to return to the main offset page.

Variation

The variation page displays the currently stored variation value.

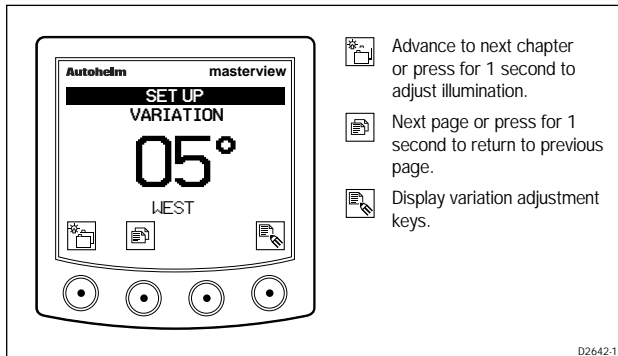

- If variation has not been set, dashes replace the variation value.
- If a value for variation is received via SeaTalk, this value is stored as the current value.

Adjusting Variation

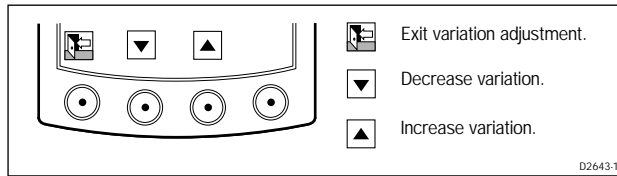

- The currently displayed value is stored as the new value if there are no key presses within 2 seconds.

True/Magnetic Heading

This page is used to select the type of heading to be displayed: local true, local magnetic, system true or system magnetic.

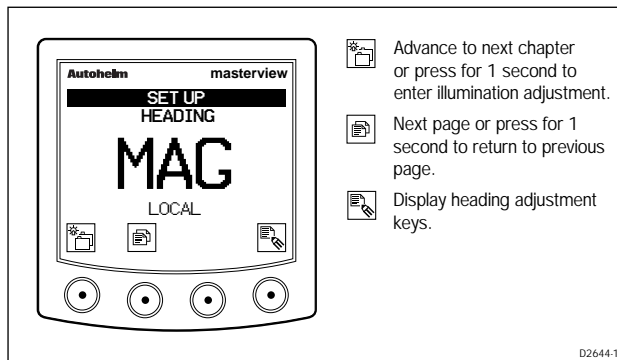





- System refers to heading information displayed by all SeaTalk display heads. Local refers to heading information displayed by a single display head only.

For example; you may wish to have all your display heads displaying magnetic headings. However, the navigator may want true heading information at the chart table. By selecting local true on the head at the chart table, the navigator can view all headings in true values while all the others heads display magnetic.

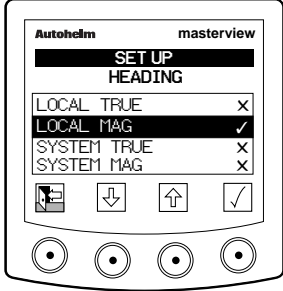
Changing the Heading

The type of heading displayed by this unit can be modified as follows:



-  Return to the main heading page.
-  Highlight next listed option.
-  Highlight previous listed option.
-  Select highlighted option.

D2645-1





- True options is not be available if variation is unknown.

Heading Lock

This setup page allows you to select the mode of operation for the locked heading feature: system or local.

System refers to the locking heading mode operating globally whereas local restricts locked heading to the display head on which local is set.



-  Advance to next chapter or press for 1 second to enter illumination adjustment.
-  Next page or press for 1 second to return to previous page.
-  Select alternative display format.
-  Turn highlighted format off.
-  Turn highlighted format on.



D4140-1

2.8 Navigate

The navigate chapter is used to adjust the response for the cross track error (XTE) page and to set the radius for the waypoint arrival alarm.

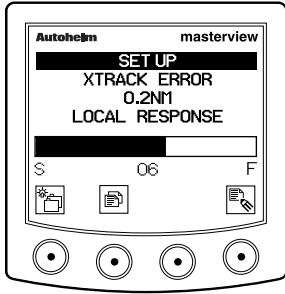
XTE Response





-  Advance to next chapter or press for 1 second to enter illumination adjustment.
-  Next page or press for 1 second to return to previous.
-  Display response adjustment keys.

D2646-1

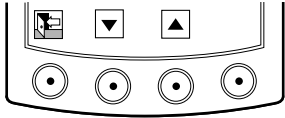
Adjusting XTE Response



-  Exit response adjustment.
-  Decrease response.
-  Increase response.



D2647-1

- The response range is from 0 (most damping) to 15 (least damping).

Waypoint Arrival Radius

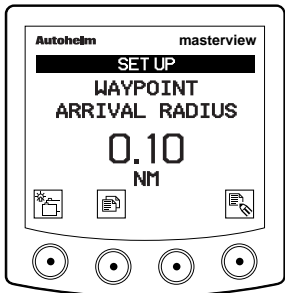
This page is used to set a radius for the waypoint arrival alarm.



-  Advance to next chapter. Press for 1 second to enter illumination adjustment.
-  Advance to next page. Press for 1 second to go to previous page.
-  Enter edit radius mode.

D4053-1

Adjusting the Radius

The waypoint arrival radius is adjusted in exactly the same way as XTE response.

2.9 Pilot Setup

This chapter is used to configure the Masterview for use with an autopilot.

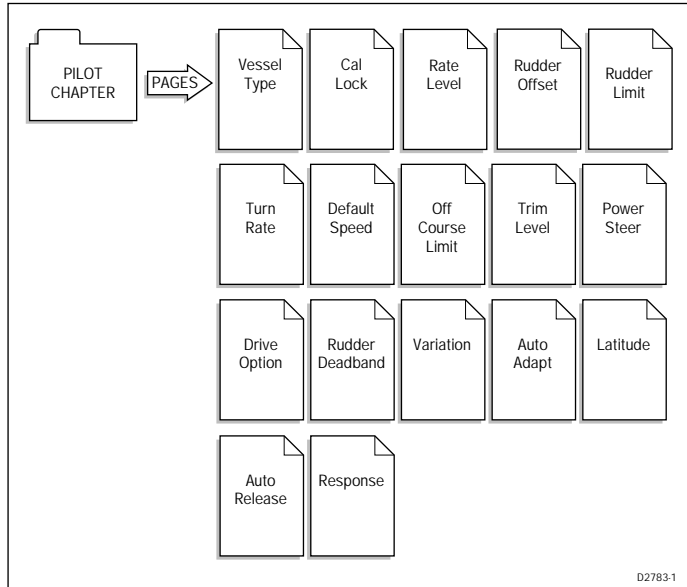

- Depending on the type of vessel you selected, some of the pilot pages may not appear.

Pilot Calibrate Entry Screen

The following screen is displayed when you stop at the pilot chapter.

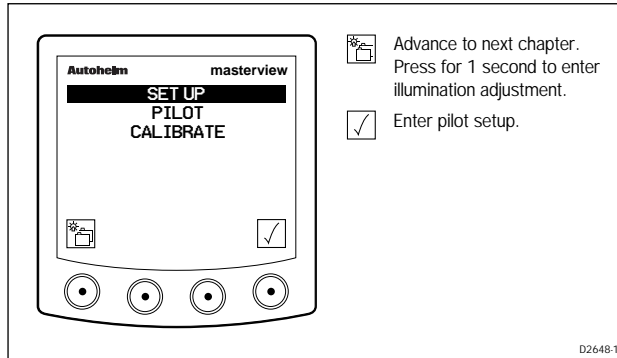

- This feature is not available if the auto pilot is in auto mode or you do not have an autopilot.

Vessel Type

This page is used to set the type of vessel the autopilot will be used on.

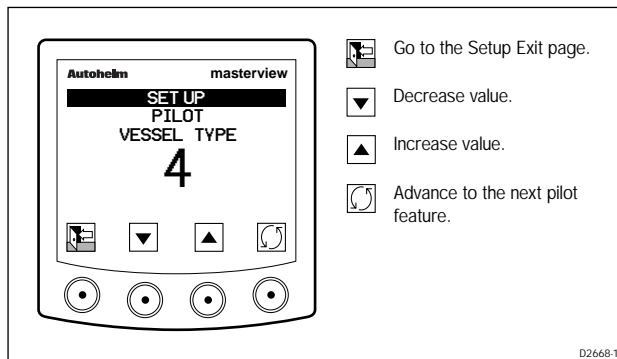

The available settings are:

- (a) Displacement: 1
- (b) Semi displacement: 2
- (c) Planing: 3
- (d) Stern drive: 4

Cal Lock

Cal Lock is used to control access to the compass linearisation setup displays.

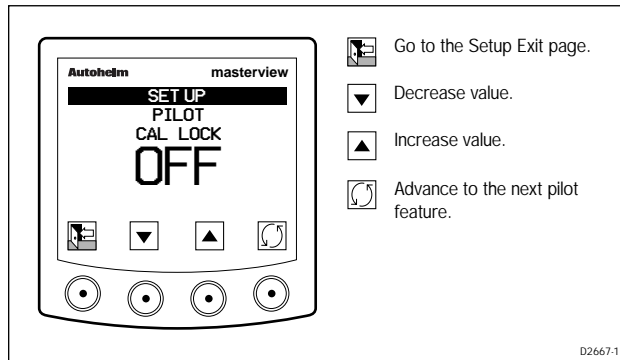

There are just two settings: ON (access available) and OFF (access denied).

Rudder Gain

Rudder gain controls the amount of rudder that the autopilot applies when turning onto a new heading.

- A correctly set gain will, for a course change of 40°, turn a vessel crisply onto the new heading with an overshoot of no more than 2° to 5°.
- A high gain will result in oversteer, recognised as an overshoot in excess of 5°.
- A rudder gain that is too low results in understeer and poor steering performance.

Warning: **It is important to set the gain correctly on planning vessels. Incorrect adjustment will lead to poor steering performance and is dangerous at high speeds.**

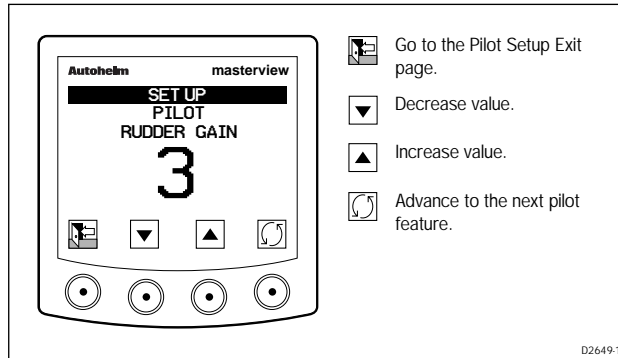

The recommended rudder gain settings are:

- (a) Displacement craft: 5
- (b) Semi displacement: 5
- (c) Planing: 4
- (d) Stern drive: 3

Rate Level

This feature controls the amount of rudder the autopilot applies to reduce the turning speed. This is also known as counter rudder and is only used with response level 3.

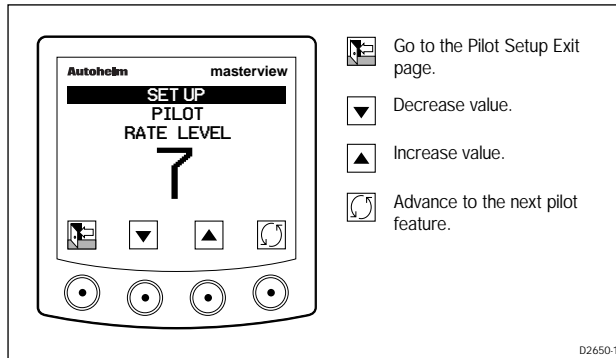

The recommended settings are:

- (a) Displacement craft: 7
- (b) Semi displacement: 7
- (c) Planing: 7
- (d) Stern drive: 5

Rudder Offset

This sets the display head to read “0” degrees of rudder when the helm is positioned amidships.

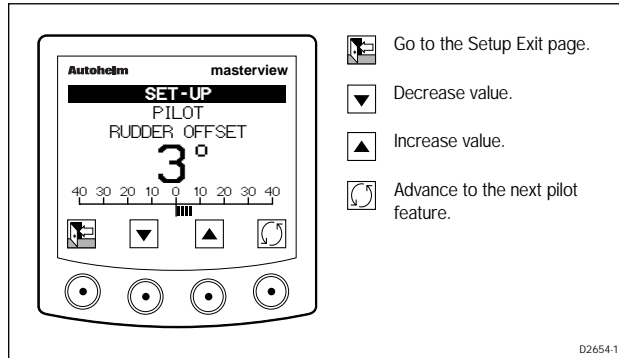

- The bar indicator shows the current position of the rudder.

Rudder Limit

Rudder limit restricts the autopilot rudder movement to just less than the steering systems mechanical stops. This is to avoid putting the steering system under unnecessary load.

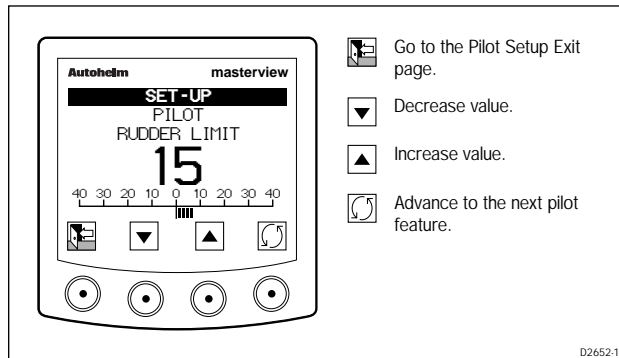

- The rudder limit range is from 15° to 40°.
- The rudder angle indicator shows the current position of the rudder.

Turn rate

Turn rate is the rate in degrees per second at which course changes are applied under autopilot control.

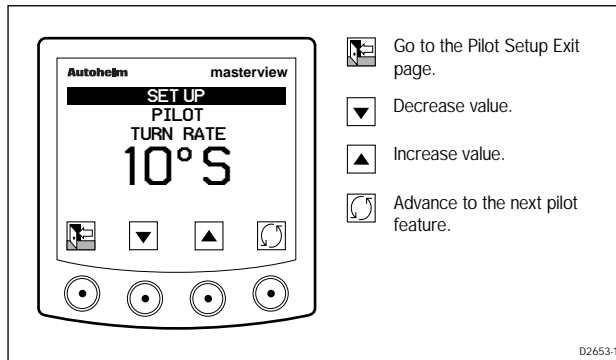

The range is from 5° to 20° per second. The default settings are:

- (a) Displacement craft: 20°
- (b) Semi displacement: 15°
- (c) Planing: 15°
- (d) Stern drive: 8°

Default Speed

Default speed is used when track mode is engaged, and should be set to your vessel's normal cruising speed.

Note: If boat speed or speed over ground is available, this is used in preference to cruise speed.

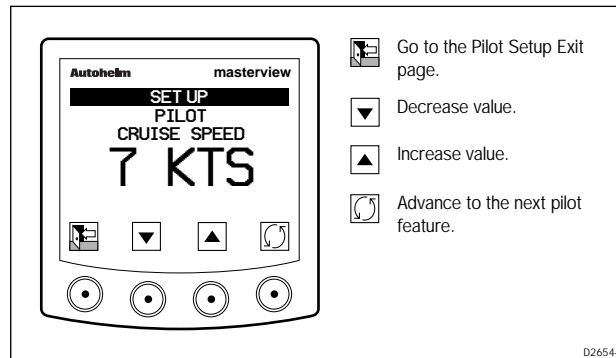

Off Course Limit

Off course limit tells you if the autopilot is unable to maintain its set course, and has subsequently strayed by more than the set limit for more than 20 seconds.

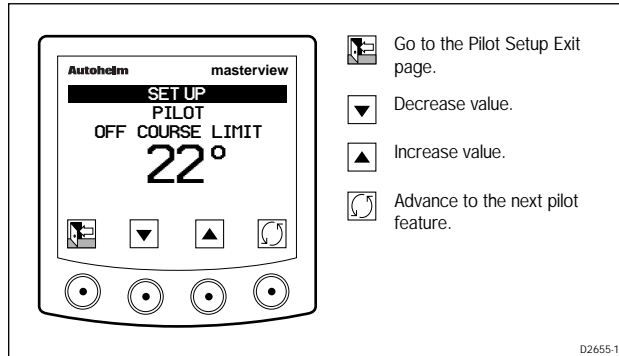

- The range is 15 to 40°.
- The default setting is 20°.

Trim Level

This sets the level for automatic trim. This applies additional rudder to correct for weather helm and other causes of static heading errors.

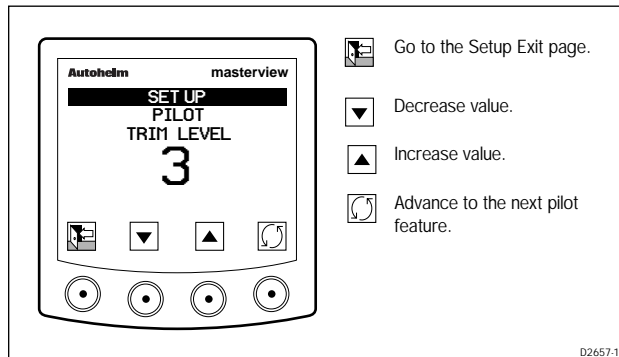

The trim level settings available are: 0, 1, 2, 3 and 4

- | | |
|------------------------------|---|
| (a) Heavy displacement: | 1 |
| (b) Displacement: | 2 |
| (c) Semi displacement: | 3 |
| (d) Planing and Stern drive: | 3 |
| (e) Fast Planing: | 4 |

Power Steer

Power steer is used to select the operating mode for a joystick: proportional or velocity.

Proportional applies rudder in proportion to movement of the joystick – the further the joystick is held over the greater the applied rudder.

Velocity applies continuous rudder drive in the direction of lever movement. To improve control, the speed of rudder movement changes with the angle of the lever.

For maximum speed, push the lever hardover. If the lever is returned to the centre position the rudder will remain at its current position.

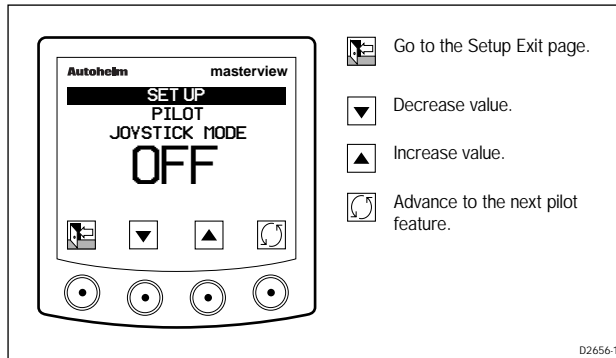

The available settings are:

- (a) OFF
- (b) Proportional
- (c) Velocity

The default setting is proportional.

Note: Please refer to the joystick and course computer handbooks for setting up procedures.

Drive Option

The drive option sets the type of drive used by your vessel.

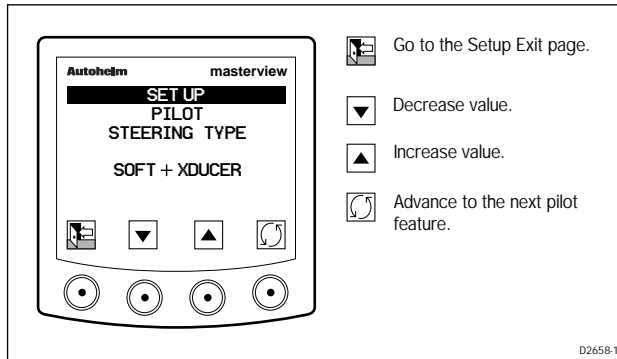

The available options are:

- (a) Soft + tacho (for diagnostics use only)
- (b) Hard + tacho (for diagnostics use only)
- (c) Soft + Xducer (For mechanical drives)
- (d) Hard + Xducer (for hydraulic drives)

Rudder Deadband (Damping)

The factory default for the rudder deadband provides a stable rudder position on most steering systems. However, some steering systems that use rotary or hydraulic drives a long way from the rudder may experience slight instability. This instability can be minimised by increasing the rudder deadband.

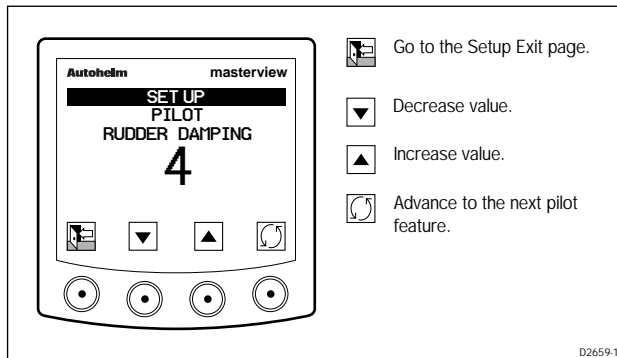

The damping range is from 1 to 9 (the factory default is 1).

Caution: Increasing this setting will reduce the steering accuracy. It is important, therefore, to use the minimum setting necessary for stable operation.

Variation

Variation tells other equipment the amount of magnetic variation present at your vessels current position.

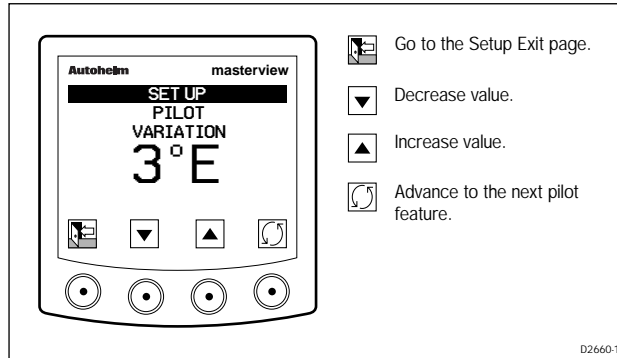

The range is 30° West to 30° East.

Auto Adapt

Autopilot's tend to be a little less stable on Northerly headings in higher latitudes of the northern hemisphere and Southerly headings in the southern hemisphere.

- This instability is caused by the increasing angle-of-dip in the Earth's magnetic field at higher latitudes.
- This instability amplifies the rudder gain on northerly (southerly) headings and affects all magnetic compasses. It also gets worse the further away you are from the equator.

The autopilot can compensate for this, and provide precise course keeping on all headings, by automatically adjusting the autopilot gain depending on the heading.

- The Auto Adapt facility should be selected for high speed craft.
- Auto adapt automatically reduces the effects of Northerly/Southerly heading instability.

This feature is selected in User Setup by entering the vessel's operating latitude. Once selected, manual adjustments are not required as the Rudder Gain is adjusted automatically.

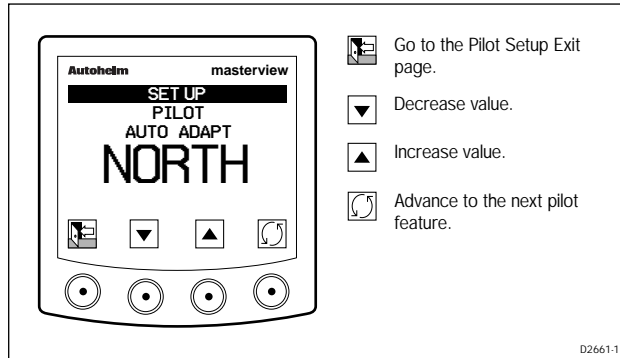

- Auto adapt can be set to: OFF, North or South.

Latitude

Latitude compensates for Northerly/Southerly heading errors.

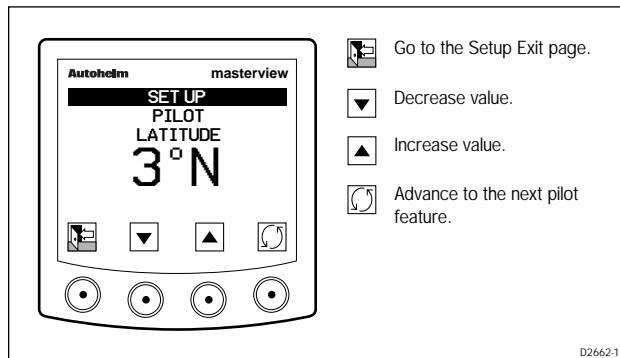

- The default setting is 0° with a range of 0 to 80°.

Auto Release

Auto release applies to Autohelm stern drive actuators only. This feature provides emergency manual override if, for example, you need to avoid an obstacle at the last moment.

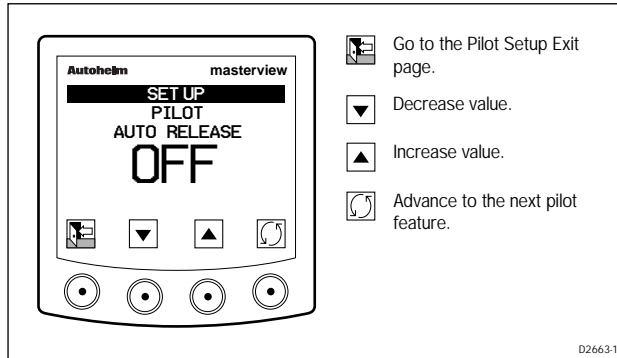

The available auto release settings are:

OFF or ON

Wind Trim Time Constant

The wind trim time constant is used to set the autopilot response when it is in vane mode.

There are just two response settings: SLOW or FAST.

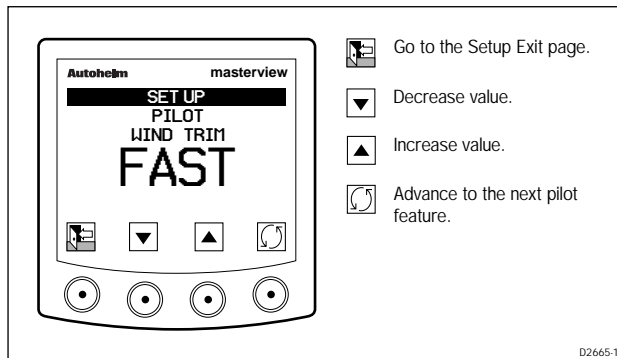

Response

This sets the response level when the autopilot is switched on.

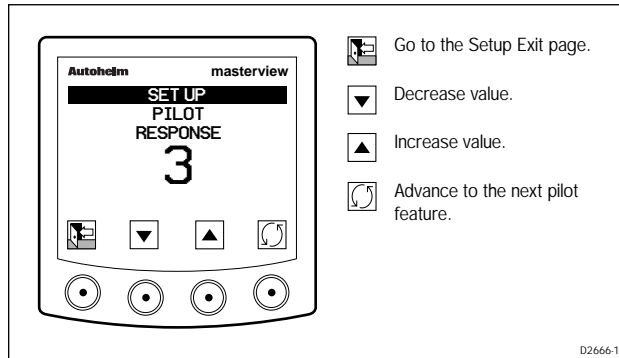

The available response settings are:

- | | |
|---|---|
| (a) Automatic sea state control: | 1 |
| (b) Automatic sea state inhibit: | 2 |
| (c) Automatic sea state inhibit counter rudder: | 3 |

The default setting is 1.

Unknown Cal Stage

The following screen is displayed if an unknown setup page is accessed. Please contact your dealer for further information.

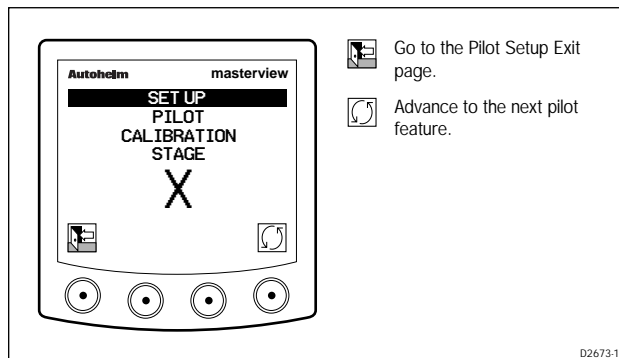

Exiting Pilot Setup

You can exit to this screen during pilot setup by pressing the left hand key.

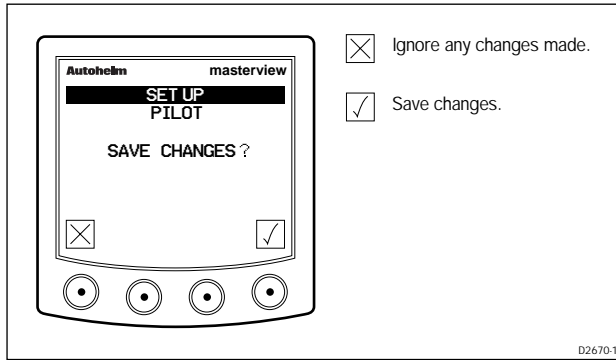

- If you ignore any changes a “CHANGES LOST” message is displayed for 2 seconds.
- If you save changes a “CHANGES SAVED” message is displayed for 2 seconds.

2.10 Timers Setup

Race Start

Race start is used to set up to three countdown alarms (guns). The following illustration shows the guns set to go-off at 15, 10 and 5 minutes before the start of a race.

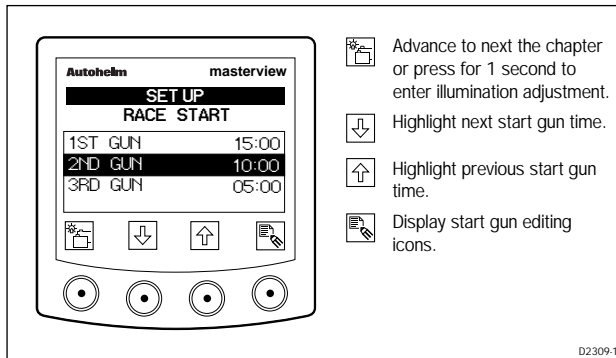





Start Guns



The screenshot shows the 'SET UP RACE START' screen with the following data:

Gun	Time
1ST GUN	15:00
2ND GUN	10:00
3RD GUN	05:00

Navigation icons are visible at the bottom of the screen.

-  Return to main race start screen.
-  Decrease highlighted start gun time.
-  Increase highlighted start gun time.
-  Switch between minutes and seconds of the highlighted start time.

D2310-1

On completion, return to the main race start display.

2.11 Environment

This chapter is used to select the units for sea temperature, °F or °C, and to make adjustments, if necessary, to remove any differences between the displayed sea temperature and the actual sea temperature (temperature offset).



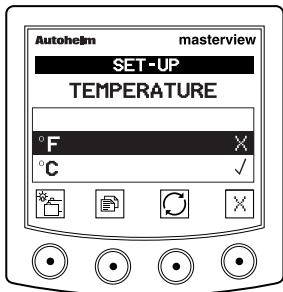

Temperature Units



The screenshot shows the 'SET-UP TEMPERATURE' screen with the following data:

Unit	Status
°F	X
°C	✓

Navigation icons are visible at the bottom of the screen.



-  Advance to next chapter or press for 1 second to enter illumination adjustment.
-  Next page or press for 1 second to return to previous page.
-  Select alternative sea temperature formats.
-  Turn highlighted format off.
-  Turn highlighted format on.

D4141.1

Temperature Offset

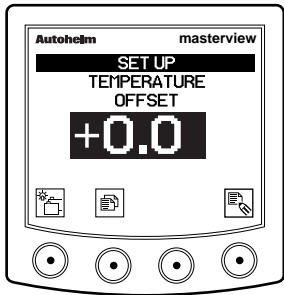
Temperature offset is selected by pressing the page key.





-  Advance to next chapter or press for 1 second to enter illumination adjustment.
-  Next page or press for 1 second to return to previous page.
-  Go to the offset edit screen.

D4142-1

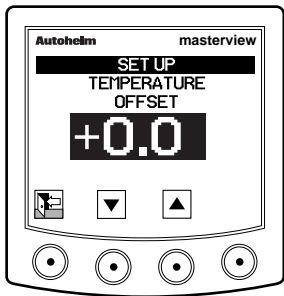
Adjusting the Offset



-  Return to previous screen.
-  Decrease highlighted value.
-  Increase highlighted value.

D4143-1

2.12 GPS Setup

The GPS setup pages are used to reset satellite related data. The options in this chapter are designed for use by service agents/dealers only.



2.13 Round Repeater

This chapter is only available when round repeaters are connected to the SeaTalk bus. Connected repeaters are listed under the main chapter heading can be scrolled using the arrow keys. The illumination brightness for each of the 3 levels can be adjusted to your requirements using the increase and decrease keys as described in previous chapters.

2.14 Multiline

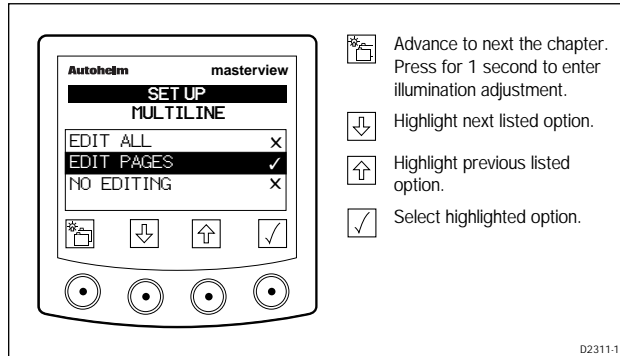
The Multiline screen is used to select the level at which you can edit chapter and page data. The options are: edit all, edit pages and no editing.







-  Advance to next the chapter. Press for 1 second to enter illumination adjustment.
-  Highlight next listed option.
-  Highlight previous listed option.
-  Select highlighted option.

2.15 Instrument Set-Up

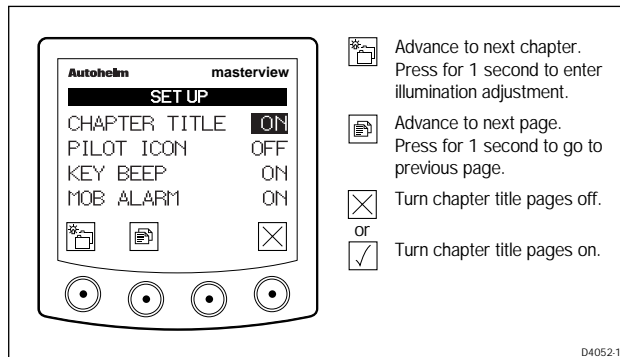
The features contained in this chapter are used to adjust basic features, for example, contrast, key beep (ON/OFF) etc.

Chapter Title Control, Pilot Icon, Key Beep & MOB



-  Advance to next chapter. Press for 1 second to enter illumination adjustment.
-  Advance to next page. Press for 1 second to go to previous page.
-  Turn chapter title pages off.
or
 Turn chapter title pages on.

Chapter Title

When a chapter is selected the title page is displayed for 2 seconds. This can be turned ON or OFF (as required) from this display.

Pilot Status Icon Control

If you regularly need to know the status of the autopilot, the normal operating icons can be set to disappear after 8 seconds of keypad inactivity.

When the normal operating icons disappear, the autopilot status icon is displayed above the right-hand key.

Key Beep

The Masterview, by default, beeps whenever a key is pressed. This can be turned ON/OFF as required.

Display Mode

Display mode is used to select the operating mode for the steering displays (for example, heading and wind steer).

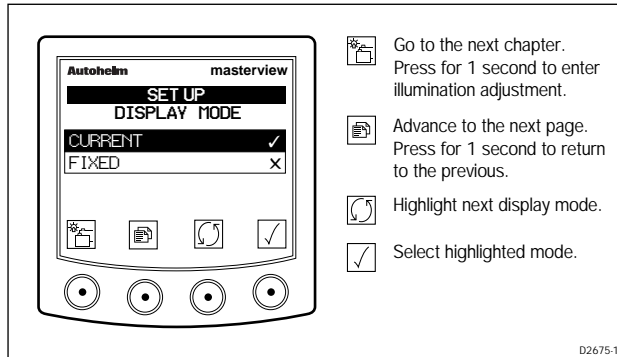

- Current mode displays the current value below the bargraph
- Fixed mode displays the locked value.

Alarm control

Alarm control determines whether the unit responds to all or specific alarms (refer to the operation chapter for details).

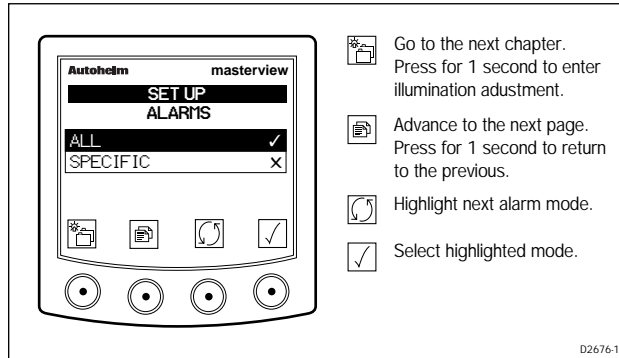

When SPECIFIC is selected (ticked), a list of all the alarms, and the status of each alarm (X = OFF), is displayed. The list of alarms can be scrolled using the up and down keys and the status changed using the right hand key.

Lamp Offset



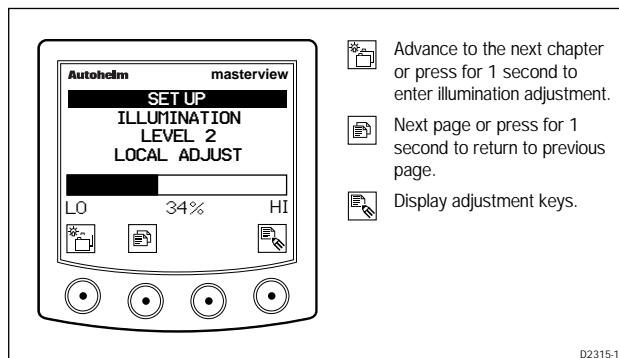

There are three available lamp settings: Level 1, Level 2 and Level 3. Each of these settings can be adjusted to the brightness of your choice.



Adjusting the Illumination Settings



The screenshot shows the masterview display with the following text: "Autohelm masterview", "SET UP", "ILLUMINATION", "LEVEL 2", "LOCAL ADJUST". Below the text is a progress bar that is approximately 34% full. Underneath the bar, it says "LO 34% HI". At the bottom of the screen are four circular buttons. To the right of the screen are four icons with corresponding text: a left-pointing arrow, an up arrow, a down arrow, and a circular arrow.

-  Exit illumination adjustment.
-  Increase setting by 1%
-  Decrease setting by 1%
-  Cycle through the illumination levels.



D2677-1

Contrast

The contrast page initially displays the current contrast setting.



The screenshot shows the masterview display with the following text: "Autohelm masterview", "SET UP", "CONTRAST", "ADJUSTMENT". Below the text is a progress bar that is approximately 60% full. Underneath the bar, it says "LO 06 HI". At the bottom of the screen are four circular buttons. To the right of the screen are three icons with corresponding text: a right-pointing arrow, a left-pointing arrow, and a hand icon pointing to a key.



-  Advance to the next chapter or press for 1 second to enter illumination adjustment.
-  Next page or press for 1 second to return to previous page.
-  Display contrast adjustment keys.

D2316-1

Adjusting the Contrast



The screenshot shows the masterview display with the following text: "Autohelm masterview", "SET UP", "CONTRAST", "ADJUSTMENT". Below the text is a progress bar that is approximately 50% full. Underneath the bar, it says "LO 05 HI". At the bottom of the screen are four circular buttons. To the right of the screen are three icons with corresponding text: a left-pointing arrow, an up arrow, and a down arrow.

-  Exit contrast adjustment.
-  Increase setting by 1
-  Decrease setting by 1

D2317-1

- Adjustment is not normally required as the LCD contrast is automatically tuned to provide the best viewing for most installations.

Navigator Keypad Linking

This page is used to create a data link between the Masterview and the Navigator keypad.

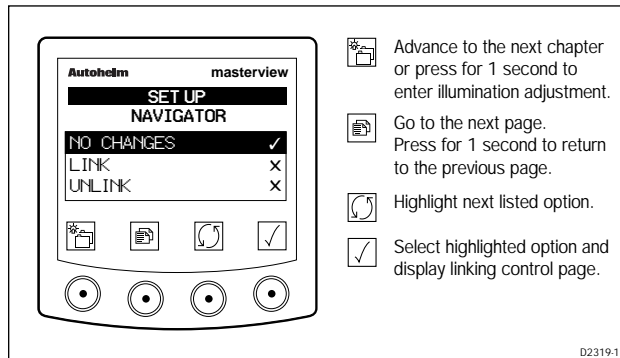

Note: If the link command has been initiated from another Masterview display head, the select icon is disabled on this head.

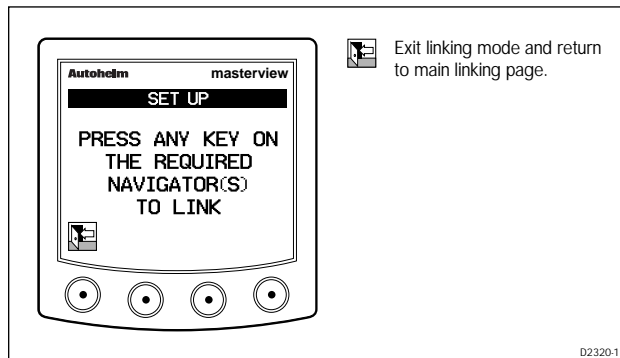

- “KEYPAD LINKED” is displayed for 2 seconds once a link has been created.

Unlinking a Navigator Keypad

The following page is displayed if you select UNLINK from the main Navigator page.

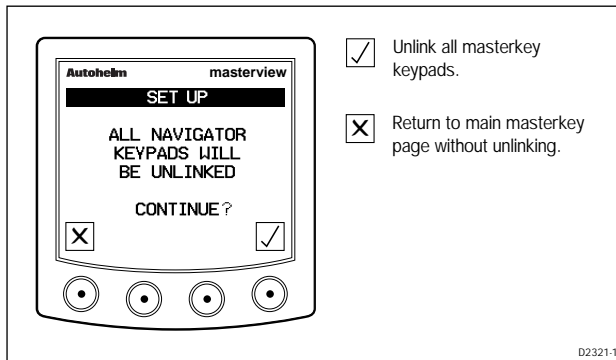

- “KEYPADS UN-LINKED” is displayed for 2 seconds when a link is broken .

CodeLock

This page is used to set the CodeLock anti-theft feature. There are three modes: OFF, MANUAL and AUTO.

If you select MANUAL you have to enter your chosen four-figure code number every time the power supply is switched on.

AUTO automatically transmits your code when the power supply is switched on. When AUTO is selected, the unit transmitting the code should be sited in a secure location below deck.

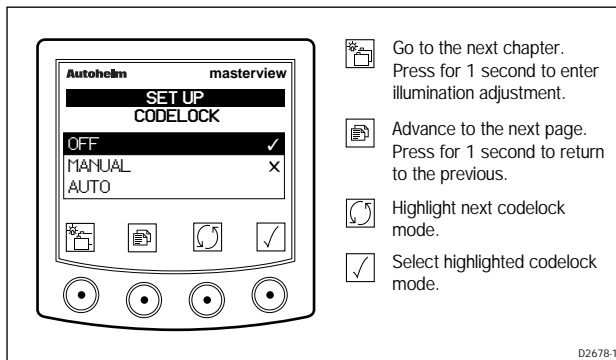

- You will be have to enter a new code number if you select AUTO or MANUAL from OFF.

Entering a New Code

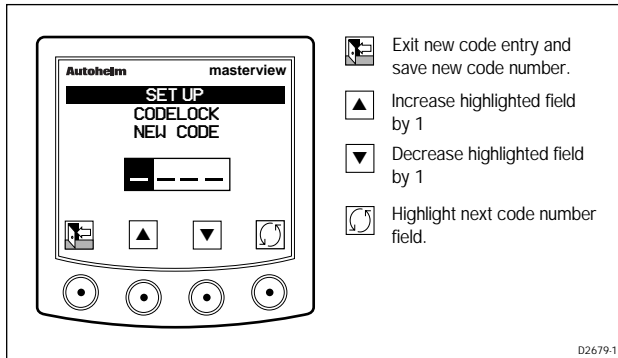

- The code number will not be stored if you exit new code entry with a dash present in the code number.

Turning CodeLock Off

To turn CodeLock off you must enter the correct code number (using the keys as shown) and quit by pressing the exit key.

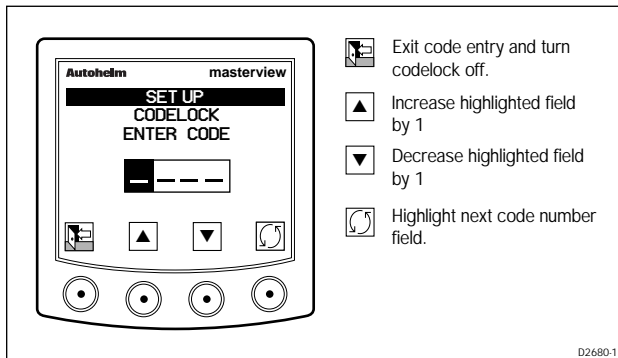

- The display returns to the CodeLock setup page when a code is cleared.
- A message is displayed for 4 seconds if an incorrect code is entered.
- This message will be displayed for 60 seconds if an incorrect code is entered on three consecutive occasions.

Transducer List

The transducer list identifies transducers connected to SeaTalk.

- Connected transducers are identified by a ✓.
- Transducers not connected appear in name only.

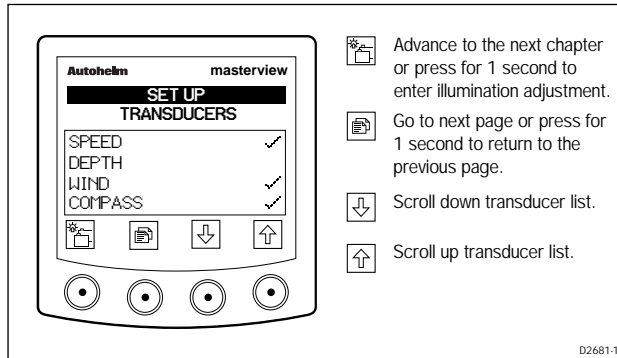

Boat Type

This page is used to set the chapter and page contents for different types of boats (see the getting started chapter for a complete list of chapter and page contents for the sail and power selections).

The custom option allows you to select the chapters and pages of your choice.

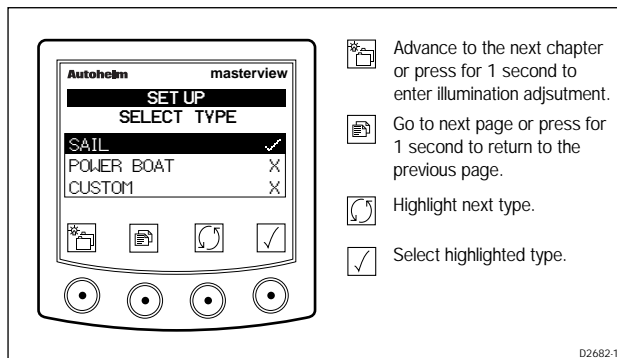

Upon selection of custom, the display automatically advances to the chapter selection page.

Custom Chapter Selection

This page is used to select the chapters of your choice from: Speed, Depth, Wind, Heading, Navigate, Pilot, Pop-Up Pilot, Timers, Environment, Nav Status, Multiline and Maxiview Remote.

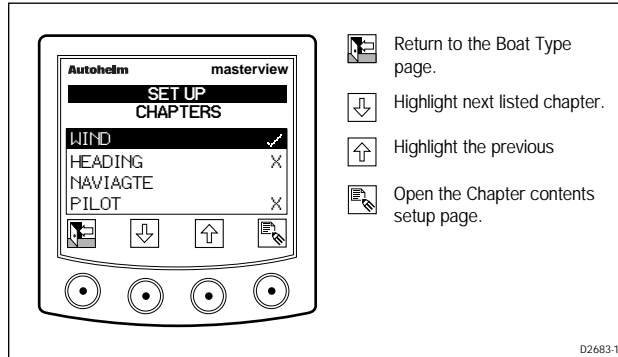

- Return to the Boat Type page.
- Highlight next listed chapter.
- Highlight the previous
- Open the Chapter contents setup page.

- Selected chapters (chapters with pages enabled) are identified by a ✓.
- Disabled chapters (no pages selected) are identified by a X.
- If a chapter appears in name only, data for this chapter is not currently available.

Selecting Pages

The chapter contents page is displayed if you press the edit key when a chapter is highlighted.

This screen allows you to select the pages that you want to appear in a given chapter.

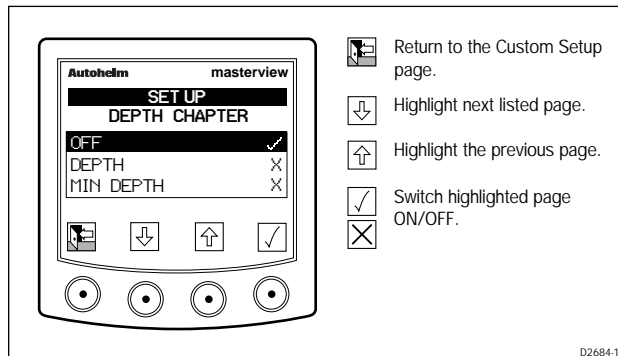

- Return to the Custom Setup page.
- Highlight next listed page.
- Highlight the previous page.
- Switch highlighted page ON/OFF.
- Switch highlighted page ON/OFF.

- Selecting OFF turns all the selected pages within the current chapter off.

- Deselecting OFF automatically switches all the previously selected pages back on.

2.16 Quitting User Setup

You can quit User Setup and return to normal operation at any time.

- Simply press the two left hand keys momentarily to display the following page and then select the required exit mode.

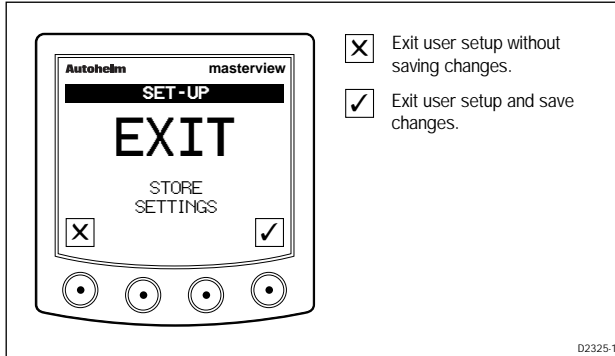

Chapter 3: CodeLock

3.1 Introduction to CodeLock

CodeLock is a personal four digit security feature designed to protect your valuable instruments against theft. You don't have to activate the system, but it's there if you need to.

There are basically two types of CodeLock compatible display heads: masters and slaves. The Masterview is a display head that can function as a master while the Maxiview, Multiview and analogue display heads are slaves.

Code creation is usually a once-off procedure carried out on a master display head, which, ideally, is situated in a secure location below deck. Once entered, the code is automatically sent to all CodeLock compatible display heads on SeaTalk without further intervention.

If you require a higher degree of security, perhaps all your instruments are mounted in exposed locations, CodeLock can demand that you enter your personal code every time the system is switched on. In this configuration, the code can be entered into any convenient digital four button display head.

A Code Locked instrument, if stolen, cannot be used without the correct code number.

3.2 Masterview Display Heads

Entering Your Chosen Code Number at Power-On (Manual High Security Mode)

If you have set CodeLock as described in the calibration chapter, enter your chosen code number using the keys as shown.

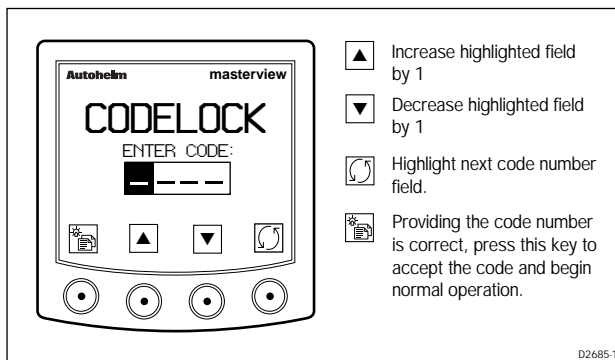

Automatic CodeLock Transmission (Auto)

If you have selected auto, your CodeLock code number will be automatically transmitted via SeaTalk to all compatible units.

3.3 Analogue Display Heads

Automatic CodeLock Systems

In an automatically transmitted CodeLock system the display head reads the number sent on the SeaTalk bus and starts-up automatically without any user input.

Manual CodeLock System

In a manually transmitted CodeLock system the code number created on the master is entered via the keypad from any CodeLock compatible instrument. This code is then sent to all compatible instruments on the same SeaTalk bus. Once this code has been received the instruments operate in the normal way.

Entering the Code Number

Unless stated otherwise, all key presses in the following chart are momentary.

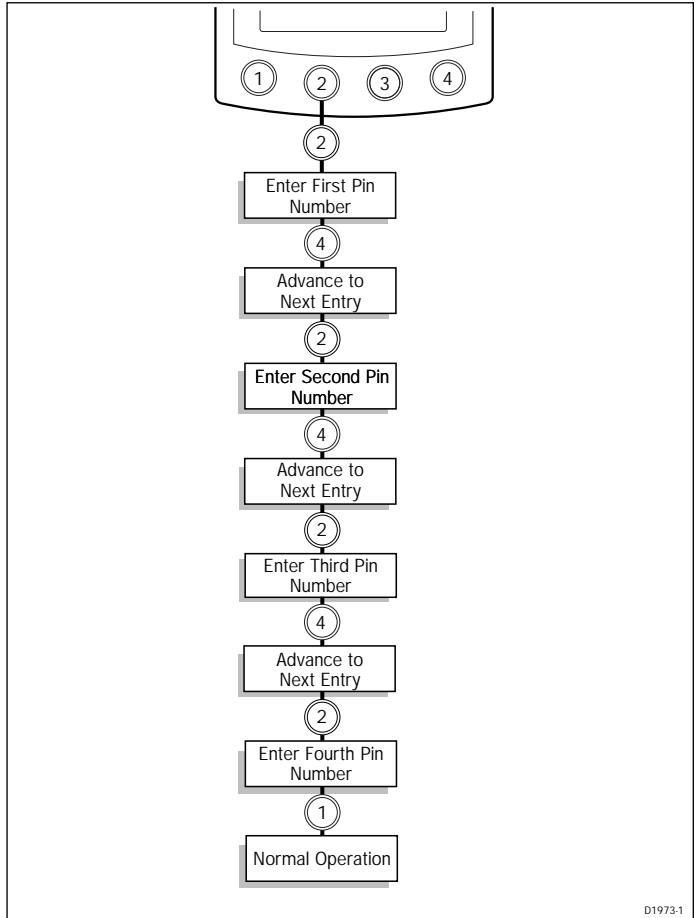

What if you enter the wrong number?

If an incorrect code number has been entered the display reads "ENTER NUMBER - - -". Repeat the procedures illustrated above entering the correct four digit number.

Chapter 4: Problem Solving

4.1 Problem Solving

Display is blank - keypad not illuminated

- Make sure that the power supply is connected.
- Check the fuse or circuit breaker.
- Make sure that the SeaTalk cables are not damaged.

Display is blank - keypad illuminated

- Check the contrast and illumination settings
- Faulty LCD module.

No exchange of information between SeaTalk instruments

- Make sure that the cables are attached securely.
- If the problem persists, disconnect your instruments one by one to isolate the faulty unit.

Failure of a group of SeaTalk instruments

- Make sure that the SeaTalk connections to non-functioning instruments are secure.

LCD shows “Code ON” when the power supply is switched on

- The CodeLock anti-theft system is operational.

Poor character definition

- Adjust the contrast.

Chapter 5: EMC and Servicing Guidelines

5.1 Important information

All Autohelm equipment and accessories are designed to the best industry standards for use in the leisure marine environment.

Their design and manufacture conforms to the appropriate Electromagnetic Compatibility (EMC) standards, but good installation is required to ensure that performance is not compromised. Although every effort has been taken to ensure that they will perform under all conditions, it is important to understand what factors could affect the operation of the product.

5.2 Installation

To avoid the risk of operating problems, all Autohelm equipment and cables connected to it should be:

- At least 1m (3 feet) from any equipment transmitting or cables carrying radio signals, e.g., VHF radios, cables and antennas. In the case of SSB radios, the distance should be increased to 2m (7ft).
- More than 2m (6ft) from the path of a radar beam. A radar beam can normally be assumed to spread 20 degrees above and below the radiating element.
- The equipment should be supplied from a different battery than the one used for engine start. Voltage drops below 10V in the power supply to our products can cause the equipment to reset. This will not damage the equipment, but will cause the loss of some information and can change the operating mode.
- Genuine Autohelm cables should be used at all times. Cutting and rejoining these cables can compromise EMC performance and so should be avoided unless doing so is detailed in the installation manual.
- If a suppression ferrite is attached to a cable, this ferrite should not be removed. If the ferrite has to be removed during installation it must be reassembled in the same position.

5.3 Check Before Going to Sea

- Always check the installation before going to sea to make sure that it is not affected by radio transmissions, engine starting etc..
- In some installations, it may not be possible to prevent the equipment from being affected by external influences. In general this will not damage the equipment but can lead to it resetting, or momentarily may result in faulty operation.

5.4 Servicing and Safety

- Autohelm equipment should be serviced only by authorised Autohelm service engineers. They will ensure that service procedures and replacement parts used will not affect performance. There are no user serviceable parts in any Autohelm product.
- Some products generate high voltages, and so never handle the cables/connectors when power is being supplied to the equipment.
- Always report any EMC related problem to your nearest Autohelm dealer. We will use any such information to improve our quality standards.

Chapter 6: Specification

Dimensions:	110 x 114.5 x 18.25mm (4.33 x 4.5 x 0.71in)
Power supply:	10 to 16 V DC
Current consumption:	50 mA with illumination off 250mA with illumination full on
Operating temperature:	-10 to +70°C (14°F to 158°F)
Illumination:	3 level LCD illumination keypad permanently illuminated

Index

A

- Adjusting a Locked Apparent Wind Steer 37
- Adjusting a Locked Heading 42
- Adjusting Boat Speed Response 103
- Adjusting the Contrast 142
- Adjusting the Current Trend Threshold 105
- Adjusting the Illumination Settings 142
- Adjusting XTE Response 122
- Alarm Adjustment 33, 34
- Alarm Control 33, 34
- Alarm control 141
- Alarm Recognition 95
- Alarm Timer Page 80
- Alarms 95
- Apparent Wind 34
- Apparent Wind Steer 42
- Audible MOB Alarm 100
- Auto Adapt 132
- Auto Release 134
- Auto Steer 69
- Auto Tack 75
- Automatic CodeLock Systems 150
- Automatic CodeLock Transmission (Auto) 150
- Autopilot Keypad 100
- Autopilot Locked 37
- Autopilot Status 74
- Average Speed 25
- Average/Maximum Speed 25

B

- Beaufort Scale 35
- Before Going to Sea 154
- Boat Speed 23
- Boat Speed Response 103
- Boat Speed Units 104
- Boat Type 146

C

- Cal Lock 125
- Calibrating using Speed Over Ground (SOG) 110
- Chapter Edit 92
- Chapter Title Page Control 139
- Check Tack 76
- CodeLock 144, 149
- Compass Linearisation 117
- Compass Offset Page 118
- Contrast 142
- Count-up Timer (Race Running Mode) 84
- Countdown Mode 83
- Course Change 74
- Course Deviation Indicator (CDI) 59, 68
- Creating a Single Destination Waypoint 55
- Cross Track Error 58
- Cross Track Error (XTE) 67
- Custom Chapter Selection 147

D

- Data Source Page 87
- Dead Reckoned MOB Data (Default) 98
- Dead Reckoning (DR) Control 61
- Default Speed 128
- Depth Alarm Control 28
- Depth Chapter 26
- Depth Display Format 112
- Depth Histogram 32
- Depth Offset 29
- Depth Offset Page 112
- Depth Units Page 111
- Display Mode 140
- Drive Option 131

E

- Editing the Depth Alarms 28
- EMC and Servicing Guidelines 153
- Entering a New Code 145
- Entering the Code Number 151
- Entering Your Chosen Code Number at Power-On 150
- Entry into User Setup 102
- Environment Chapter 86
- Exiting Pilot Setup 136

F

- First-Time Power-Up 19
- Fish Finder 30
- Fix Status Page 88

G

- Gain 31
- General Information Page 88
- General Page 63, 71

H

- Heading and Course Over Ground 38
- Heading Chapter 38
- Heading Histogram (True and Course Over ground) 42
- Heading Response 116
- Heading Steer 40
- High Priority Alarms 96

I

- Identifying High Priority Audible Alarms 96
- Identifying Low Priority Audible Alarms 97
- Illumination Selection and Adjustment 94
- Initial Start-up 101
- Installation 153
- Instrument Set-Up 139
- Introduction 15
- Introduction to CodeLock 149

K

- Key Beep 140
- Keypad Handling 100

L

- Lamp Offset 141
- Lap Reset Mode 85
- Lap Timer 81
- Lat/Lon MOB Data 99
- Latitude 133
- Line Edit 91
- Local Time Alarm Control 79
- Local Time Page 78
- Locked Mode 41
- Log Information 62
- Low Priority Alarms 97

M

- Man Overboard (MOB) 98
- Manual CodeLock System 150
- Maximum Speed 25
- Maxiview Remote Chapter 93
- Maxiview Remote Control Page 93
- Minimum Depth 29
- Modifying Local Time 79
- Multiline 139
- Multiline Chapter 90

N

- Nav Status Chapter 87
- Navigate Chapter 43
- Navigate Page 57, 66
- Navigator Keypad 100
- Navigator Keypad Linking 143
- No SeaTalk Lat/Lon Data Available 61
- No Valid MOB Data 100

O

- Off Course Alarm 40
- Off Course Limit 129
- Old Heading 77
- Old Wind Angle 77

P

- Pilot Calibrate Entry Screen 124
- Pilot Chapter 65
- Pilot Setup 123
- Pilot Status Icon Control 140
- Pop-Up Pilot Chapter 73
- Port Tack 75
- Position Page 60
- Power Mode 21
- Power Steer 130
- Problem Solving 152

Q

- Quitting User Setup 148

R

- Race Lap Mode 84
- Race Reset 84
- Race Start 136
- Race Timer 83
- Rate 31
- Rate Level 126
- Recognised Autopilot Alarms 96
- Remote Keypad 100
- Resetting the Lap Timer 82
- Response 73
- Rudder Deadband (Damping) 131
- Rudder Gain 74, 125
- Rudder Limit 127
- Rudder Offset 127

S

- Sail Mode 20
- Satellite Plot Page 89
- Sea Temperature Histogram 86
- SeaTalk Lat/Lon Data Available 60
- SeaTalk Voltage Histogram 86
- Selecting a Field to Edit 56
- Selecting Depth Units 112
- Selecting Distance Units 105
- Selecting Pages 147
- Sensitivity 31
- Sensitivity (SENS) and Gain 31
- Servicing and Safety 154
- Single Waypoint Page 55
- Specification 155
- Speed and Heading 64
- Speed Chapter 22
- Speed Display Format 106
- Speed, Heading, COG and SOG 71
- Speed, Heading, Course Over Ground, Speed Over Gro 63
- Speed Histogram 26
- Speed Over Ground and Course Over Ground 64
- Speed Transducer Calibration 106
- Speed Trend Indicators 105
- Split Race Time 85
- Split Screen Mode 89
- Split Time 82
- ST80 13
- ST80 Watch Alarm 97
- Starboard Tack 75
- Start Guns 137
- Starting Another Lap Time 82
- Status Page 66
- Steering Page 58
- Stopwatch Page 80
- Stopwatch Reset 81
- Switching the Transducer ON and OFF 111
- System Overview 13

T

Tack Course 39
 Tide 63, 71
 Time 72
 Timer Alarm 98
 Timers Chapter 78
 Timers Setup 136
 Track and Waypoint Advance 76
 Tracking to a Single Waypoint 57
 Transducer List 146
 Trim Level 129
 Trip Control 24
 Trip/Log 24
 True Wind 33
 True Wind Histogram (Speed and Angle) 35
 True/Magnetic Heading 120
 Turn rate 128
 Turning CodeLock Off 145

U

Unknown Cal Stage 135
 Unlinking a Navigator Keypad 144
 Unlocked Mode 40
 UTC Page 78

V

Vane Steer 70
 Variation 119, 132
 Vessel Type 124
 VMG to Wind 23
 VMG Trend Indicators 106
 VMG Wind Response 104

W

Water Depth 27
 Waypoint 99 99
 What if a Target Waypoint does not Exist? 60
 What if a waypoint is not selected? 69
 What if the depth echo is lost? 27
 What if you enter the wrong number? 151
 Wind 72
 Wind Angle Offset Page 114
 Wind Chapter 32
 Wind Speed & Angle Response, Wind Speed Units & Di 114
 Wind Speed Units 114
 Wind Trim Time Constant 134

X

XTE Response 122

Raymarine Ltd.
Anchorage Park, Portsmouth,
P03 5TD, England.
Telephone: +44 (0) 2392 693611
Fax: +44 (0) 2392 694642

Autohelm
