

Distributed by
Raymarine

Any reference to Raytheon or RTN in this manual should be interpreted as Raymarine. The names Raytheon and RTN are owned by the Raytheon Company.

Raystar**112**GPS

▶ GPS SENSOR

▶ OPERATION MANUAL

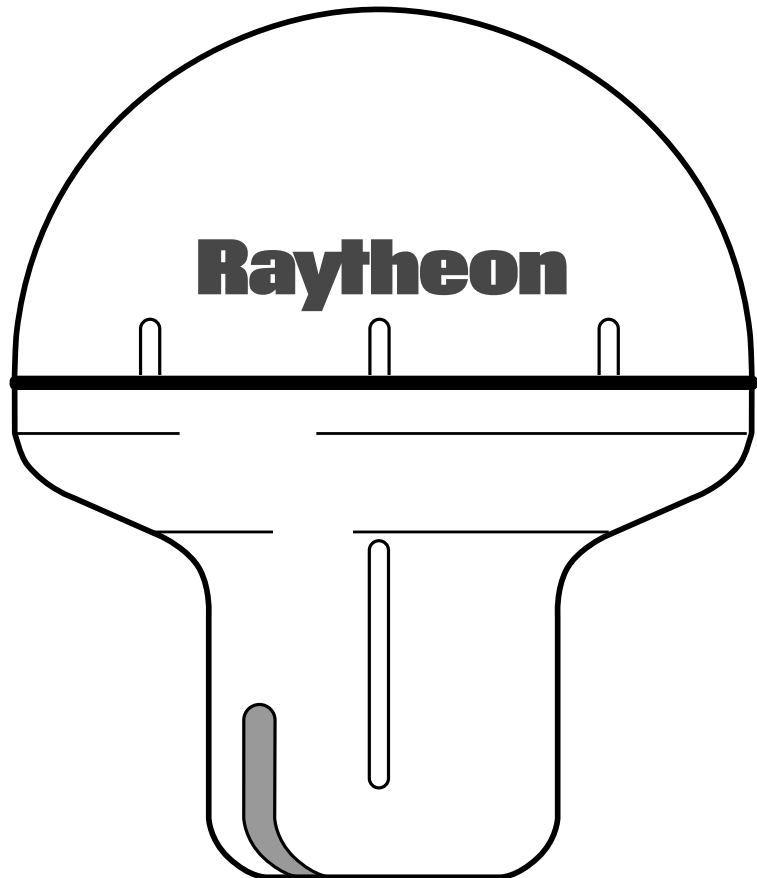



RAYSTAR 112 GPS SENSOR

Owner/Installation Manual

PURPOSE

This manual contains very important information on the installation, operation, and maintenance of your new equipment. In order to get the best results in operation and performance, please take the time to read this manual thoroughly.

IMPORTANT NOTICE

This device is only an aid to navigation. Its accuracy can be affected by many factors, including equipment failure or defects, environmental conditions and improper handling or use.

It is the user's responsibility to exercise common prudence and navigational judgement, and this device should not be relied upon as a substitute for such prudence and judgement.

RAYTHEON ELECTRONICS products are supported by a network of Authorized Service Representatives. For information on Raytheon products and services, contact any of the following:

UNITED STATES Raytheon Marine Company
676 Island Pond Road
Manchester, N.H. 03109 – 5420
Telephone: (603) 647 – 7530
Facsimilie: (603) 634 – 4756

EUROPE Raytheon Marine Europe Limited
Anchorage Park
Portsmouth
Hampshire PO3 5TD
United Kingdom.
Telephone: 44 – 1705 693611
Facsimilie: 44 – 1705 694642

© Copyright Raytheon Electronics 1997

The technical and graphical information contained in this handbook, to the best of our knowledge, was correct as it went to press. However, the Raytheon policy of continuous improvement and updating may change product specifications without prior notice. Therefore, unavoidable differences between the product and handbook may occur from time to time, for which liability cannot be accepted by Raytheon.

EMC Installation & Service Guidelines

IMPORTANT NOTE

All Raytheon equipment and accessories are designed to the best industry standards for use in the leisure marine environment.

Their design and manufacture conforms to the Electromagnetic Compatibility (EMC) Regulations, but good installation is required to ensure that performance is not compromised. Although every effort has been taken to ensure that they will perform under all conditions, it is important to understand what factors could affect the operation of the product.

Installation

To avoid the risk of operating problems, all Raytheon equipment and cables connected to it should be;

- At least 1m (3 ft) from any equipment transmitting or cables carrying radio signals e.g. VHF radios, cables and antennas. In the case of SSB radios, the distance should be increased to 2m (7ft).
- More than 2m (7ft) from the path of a radar beam. A radar beam can normally be assumed to spread 20 degrees above and below the radiating element.
- The equipment should be supplied from a different battery than the one used for engine start. Voltage drops below 10v in the power supply to our products can cause the equipment to reset. This will not damage the equipment, but will cause the loss of some information and can change the operating mode.
- Genuine Raytheon cables should be used at all times. Cutting and rejoining these cables can compromise EMC performance and so should be avoided unless doing so is detailed in the installation manual.

Check Before Going to Sea

- Always check the installation before going to sea to make sure that it is not affected by radio transmissions, engine starting etc..
- In some installations, it may not be possible to prevent the equipment from being affected by external influences. In general this will not damage the equipment but can lead to it resetting, or momentarily may result in faulty operation.

Servicing and Safety

- Raytheon equipment should be serviced only by authorised Raytheon service engineers. They will ensure that service procedures and replacement parts used will not affect performance. There are no user serviceable parts in any Raytheon product.
- Some products generate high voltages, and so never handle the cables/connectors when power is being supplied to the equipment.
- Always report any EMC related problem to your nearest Raytheon dealer. We will use any such information to improve our quality standards.

Please keep these notes for future reference.

Contents

Chapter1: Introduction	1
1.1 General Information	1
1.2 Basic GPS Information	1
Chapter 2: Installation	5
2.1 Installing the Sensor Unit	5
2.1.1 Tips on Locating the Sensor	5
2.1.2 Items Supplied	6
2.1.3 Mounting the Sensor	6
2.2 Sensor Connections	7
DC Power	7
NMEA 0183 Data Output	7
Data Input to Sensor	8
2.2.1 Connection to Raytheon Units	8
2.2.2 Connections to DGPS Receiver	8
2.2.3 Connection to External Navigation Equipments	9
2.2.4 Connection Diagram	10
Chapter 3: Operation	11
3.1 COLD Start (Initial Start-up)	11
3.2 Geodetic Datum	11
Chapter 4: Maintenance	13
4.1 General	13
4.2 Replacing the Battery	13
4.3 Trouble Shooting	14
4.4 Electrical Specifications:	15
General:	15
Mechanical Specifications:	15

Appendix A	17
Additional Local Geodetic Systems	17

Chapter 1: Introduction

1.1 General Information

Congratulations on your purchase of Raytheon's Raystar 112 GPS sensor unit. We think you will appreciate the accuracy of GPS, the quality, long-term reliability, and additional space saving convenience of having GPS navigation data available at your navigation console from your new Raystar 112.

Built into the environmentally rugged, compact housing is our newest 12 channel GPS receiver/processor combined with the ADP antenna. The position output data from the Raystar 112 can be displayed on radars, plotters, fishfinders, lorans, and other navigation equipment capable of accepting NMEA 0183 formatted data.

1.2 Basic GPS Information

GPS is a satellite-based radionavigation system developed and operated by the U.S. Department of Defense (DOD). GPS permits land, sea and airborne users to determine their three-dimensional position, velocity, and time 24 hours a day, in all weather, anywhere in the world with a precision and accuracy far better than other radionavigation systems available today or in the foreseeable future.

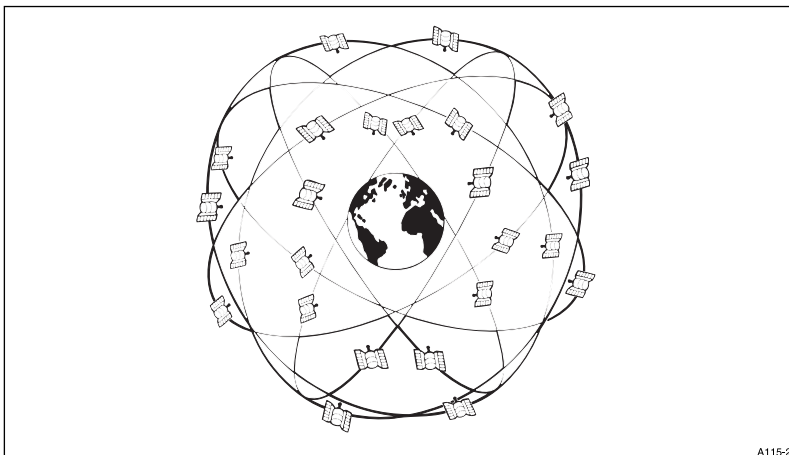

GPS consists of three segments: space, control and user.

The Space Segment, consists of 24 operational satellites in six circular orbits 20,200 km (10,900 nm) above the earth at an inclination angle of 55 degrees with a 12 hour period. The satellites are spaced in orbit so

that at any time a minimum of 6 satellites will be in view to users anywhere in the world. The satellites continuously broadcast position and time data to users throughout the world.

The Control Segment, consists of a master control station in Colorado Springs, with five monitor stations and three ground antennas located throughout the world. The monitor stations track all GPS satellites in view and collect ranging information from the satellite broadcasts. The monitor stations send the information they collect from each of the satellites back to the master control station, which computes extremely precise satellite orbits. The information is then formatted into updated navigation messages for each satellite. The updated information is transmitted to each satellite via the ground antennas, which also transmit and receive satellite control and monitoring signals.

The User Segment consists of the receivers, processors, and antennas that allow land, sea, or airborne operators to receive the GPS satellite broadcasts and compute their precise position, velocity and time.

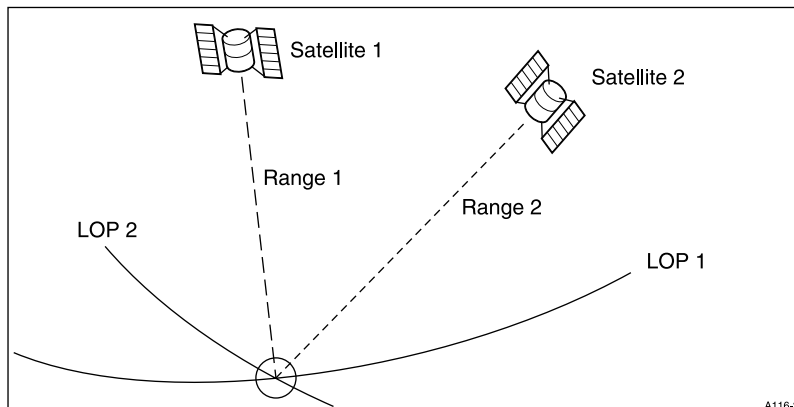

The satellites continuously broadcast their navigation messages at a frequency of 1575.42 Mhz (for civilian use). Superimposed on the navigation message is a high rate coarse acquisition (C/A) code used for precise positioning measurements and positive satellite identification. The C/A ID code permits the user to identify particular satellites and, in some cases, to determine and select the “best satellites” to use in position calculations.

If it were possible to measure true satellite ranges directly, it would only be necessary to track data from any two satellites to obtain a vessel's latitude/longitude. In actual practice, for marine navigation, the receiver must lock onto and track a minimum of three satellites in order to resolve timing errors, including the receiver's own internal clock timing bias error which must be factored into the various range calculations.

Normally the Raystar 112 tracks up to 12 satellites (if visible) and uses all tracked satellites for calculating position fixes. By using these satellites, the processor can determine the amount of clock errors in each range calculation. The receiver subtracts the error bias equally from each range solution until the lines of position (LOP's) intersect.

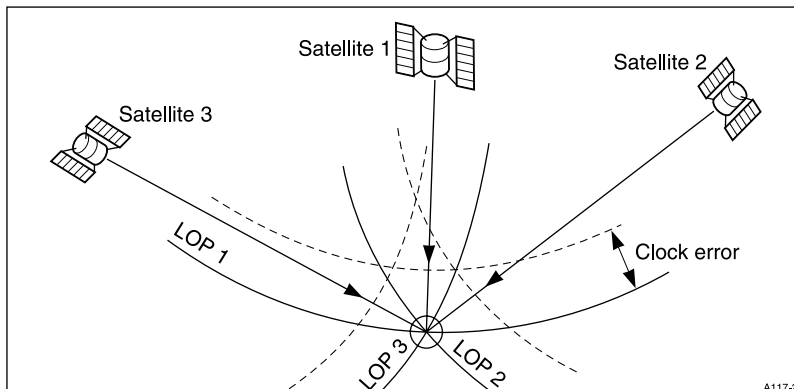

Theoretically, this process can produce highly accurate latitude/longitude (L/L) position fixes for navigation within $\pm 15\text{m}$ (rms).

Continuous tracking of each satellite allows the receiver to perform this timing adjustment process and to calculate accurate measurements to the satellites. The Raystar 112 uses a 12 channel receiver. This sensor design method provides fast efficient acquisition and accurate position updating, even when satellites are obstructed from view.

The US Department of Defense, for security reasons, has included a special mode in the GPS satellite system design which introduces variable timing errors into the satellite signals. This mode is known as "Selective Availability" (SA), and when it is enabled, is designed to provide less accurate fixes for all users (except military users). Accuracy in the order of ± 100 Meters (rms) 95% of the time is obtained when SA is ON. This means that 95% of the time the actual ship's GPS Lat/Long position will be within a radius of 100 meters (\pm one football field) and 5% of the time the actual position will be out of this 100 meter circle. Selective Availability has been enabled almost continuously since early 1991.

The use of Differential GPS technology can remove most of these intentionally induced errors in the GPS satellite signals due to the "Selective Availability" mode including errors that can result due to environmental conditions as the satellite signals travel to earth. When you attach Raytheon's Differential Beacon Receiver to the Raystar 112 GPS sensor, the GPS differential corrections can improve the L/L

position output accuracy of the Raystar 112 from +/- 100 meters down to 5 to 8 meters in most cases.

The Raystar 112 provides NMEA 0183 formatted data at its output as follows:

RMC	Combines position, course, and speed
GLL	Vessel's Latitude/Longitude position
VTG	Course over the ground, Speed over ground
GGA	Ships L/L position & satellite status information
GSA	Active satellites and DOP
GSV	Satellites in view

This data can be supplied to plotters, fishfinders, radars, integrated systems, etc., which are set up to use these sentences from the NMEA 0183 format.

Please read through this manual thoroughly before proceeding with the installation and operation of the sensor. There are some important recommendations regarding successful installation practices to follow for getting the best GPS sensor performance.

In the back of this manual you will also find a warranty registration card for your Raystar 112. To ensure that your unit is registered for full warranty coverage, please take a few moments to fill in the necessary information, and return the card to Raytheon. No postage is required if the card is mailed in the USA.

Chapter 2: Installation

2.1 Installing the Sensor Unit

2.1.1 Tips on Locating the Sensor

The sensor is designed to receive the signals emitted from the satellites in a direct path. Ideally, the antenna unit should be mounted vertically in a location that is open and clear of any masts, search lights, or other structures that could block the line-of-sight reception of the antenna unit. The height of the GPS sensor is not as important as the sensor having a clear view horizon to horizon for ideal signal reception. In fact, the lower the antenna can be mounted and have a clear view to satellites, the better. The more stable the antenna, the easier it is to track satellites lower to the horizon. On sailboats, mounting the GPS to mast tops should generally be avoided.

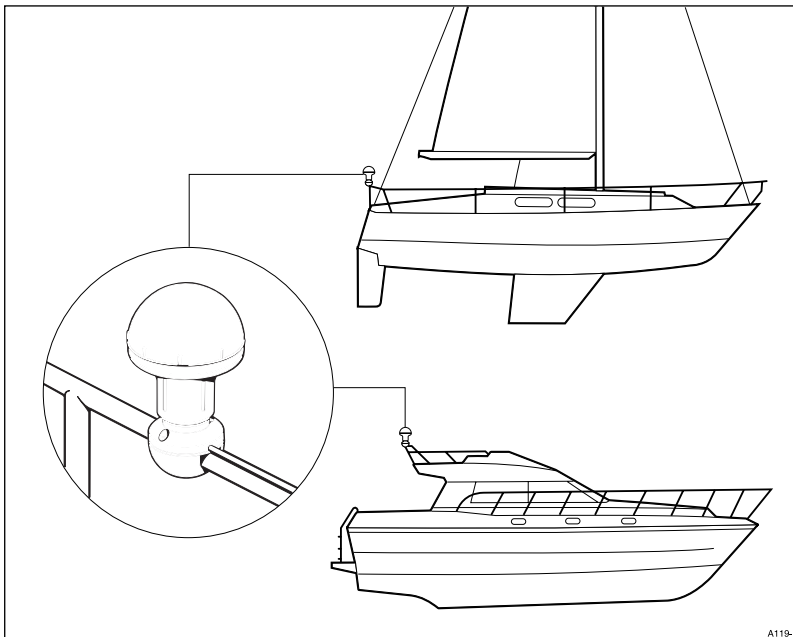

The GPS sensor should be separated by at least 3 ft (1m) from other communication antennas and should not be mounted in the direct path of the radar's antenna beam.

While planning the location for the sensor, consider finding a convenient pathway for running the interconnecting cable which will connect the GPS sensor to the GPS display unit. Ideally the cable should be run in a manner so it can be hidden from view and, if possible, be in a direct path

to the point of connection. It is important to keep the cable separated from other shipboard cables as much as possible to prevent interference pickup.

2.1.2 Items Supplied

- 1 each Raystar 112 GPS Sensor Unit, with 33ft (10 m) cable
- 1 each Instruction Manual

2.1.3 Mounting the Sensor

The aluminum base of the sensor is threaded for use with a standard 1 inch x 14 NPT marine antenna mount or extension mast. The base of the sensor has a slot cut into it so that the prewired cable can be fed externally of the mount or extension mast if so desired. If the connector is removed, the cable can be fed down through the extension mast or mount, exiting through the mount assembly.

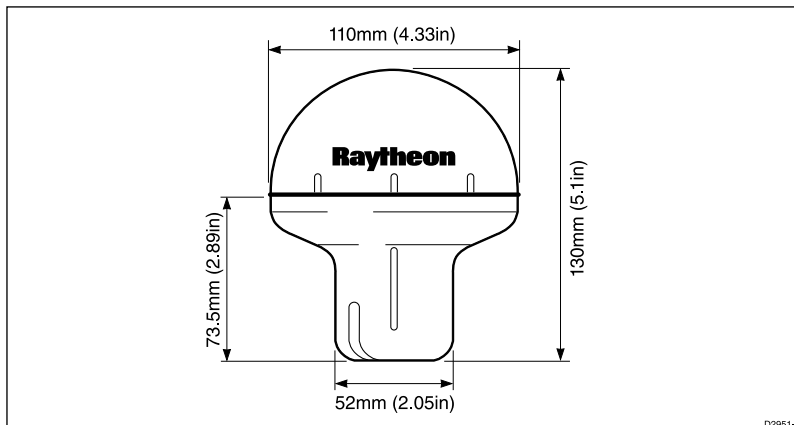

The aluminium base of your Raystar 112 Sensor has received a chromation treatment which adds toughness, resistance to wear and tear, and resistance to corrosion of the assembly. Prior to attaching the GPS sensor to the mount, we do recommend that a light coating of the silicon grease be applied to the surface of the threads of the sensor and mount.

Screw the antenna onto the mount fully by hand while paying attention to avoid curling, tight loops, and kinking of the cable. When the unit is fully threaded on the mount use a proper sized spanner wrench and protective cloth to grip the base and snug the sensor to the mount.

If the cable is fed internally through an extension mast, it is recommended that the cable slot in the sensor base assembly be sealed with RTV silicon sealant as protection from the environment. If

the cable is fed externally through the slot, the cable should be tyrapped or clamped at the base. Then the slot in the base should be sealed with RTV silicon sealant.

The cable assembly supplied is 33 ft (10 m) in length with a 6 pin connector installed at the receiver end. The cable should be run as directly as possible to the navigation console or to the external navigation device. The cable may either be cut as necessary to the desired length or coiled and stored out of the way.

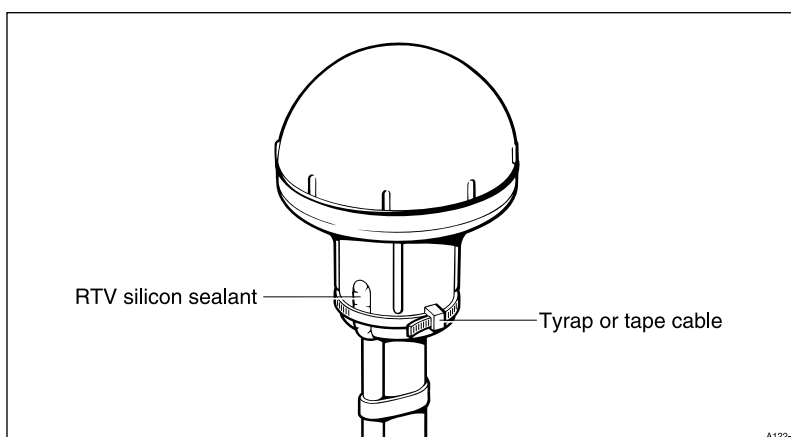

If the cable is cut to length, the cable may be rejoined by following the connection diagram in section 2.2.4.

2.2 Sensor Connections

The Raystar 112 sensor has the following input/output requirements:

DC Power

The 12 VDC power input to the sensor should be in the range of 11 to 16 VDC. It is important to verify that these voltage limits will not be exceeded to protect the GPS sensor unit. The negative leg of the 12V is grounded at the sensor base. If the vessel has a floating 12VDC system, an insulator must be used between the sensor base and mount to isolate the sensor from the ships ground.

NMEA 0183 Data Output

The NMEA 0183 Data contains RMC, GLL, VTG, GGA, GSA and GSV sentences. Please note that the sensor output is guaranteed to drive only 2 (two) devices directly. When using modern low current NMEA 0183 listener devices, up to 5 units can be driven in parallel. Contact your dealer if there are any questions regarding interfacing capabilities.

Data Input to Sensor

The sensor data input line is used to provide initialization data to the sensor unit as well as other set-up information, such as geodetic datum selection. This data is ordinarily provided via Raytheon’s GPS display units (RayNav 298, RayNav 398, etc.).

2.2.1 Connection to Raytheon Units

When the Raystar 112 sensor is connected directly to one of Raytheon’s GPS display units, it normally obtains its 12VDC operating power input from the unit. In this typical installation, the 6 pin sensor connector is plugged directly into the connector labeled “GPS” on the rear of the display unit cabinet. The DC power is then supplied via pins 1 and 2 of the GPS connector to the sensor.

Other external equipment requiring GPS data input should obtain their required NMEA 0183 data via connection to the data output wires located in the NAV display unit power cable assembly.

2.2.2 Connections to DGPS Receiver

The Raystar 112 is designed to accept differential corrections in the RTCM Version 2.1 format from the Raytheon DGPS Beacon Receiver. The corrections from the Beacon receiver pass directly to the GPS sensor. A convenient “Y” cable assembly is packaged with the Beacon receiver to permit this interconnection. The diagram below shows the configuration.

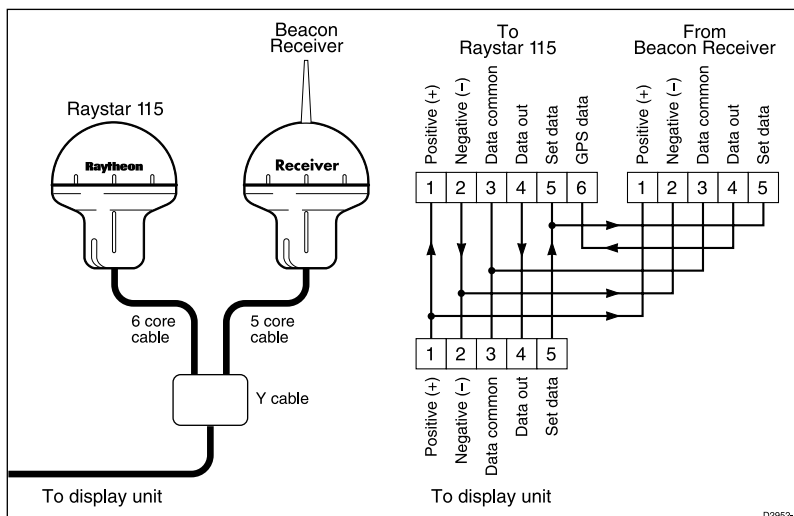

2.2.3 Connection to External Navigation Equipments

The diagram shown below should be followed to make connections of the NMEA 0183 data to external units. A terminal strip would provide a convenient means for attaching the necessary inputs and outputs.

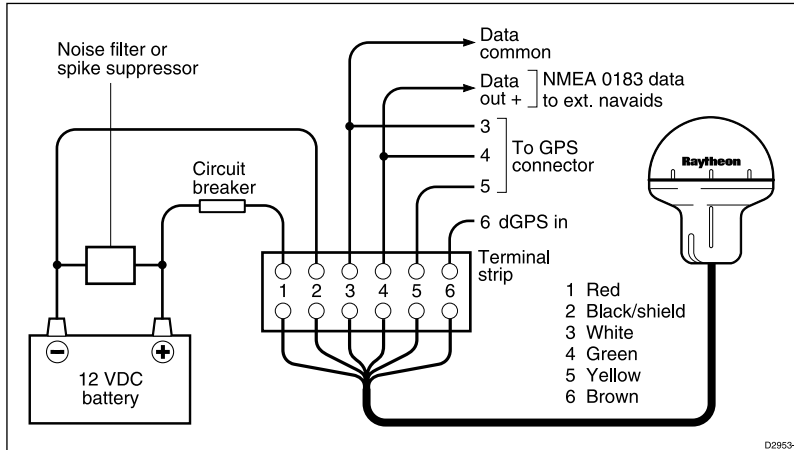

WARNING: OBSERVE PROPER POLARITY!

The 12VDC power leads should normally be routed to the ship's DC power distribution panel on larger boats. The unit draws approximately 0.25 amps, so connection to a circuit breaker rated at 5 amps or less is recommended. On smaller vessels the power leads should be connected to a panel switch or to the main battery isolation switch or breaker.

For best noise immunity from other shipboard electronics, avoid grouping the GPS sensor power connections together with the radar, radio, or echo sounder power leads on the same circuit breaker, if possible. The GPS's wiring should be separated as much as possible from these other devices.

When using the NMEA 0183 format, the Raystar 112 can provide data for at 2 or more navigation equipments when connected in parallel. Be sure that all devices connected to the data output (plotters, video sounders, radars) are programmed to use the NMEA 0183 data format.

WARNING: Do NOT GROUND the Data, Data return lines, or the Shield of the interface cable at any of the external navigation equipments.

Interface between equipments is normally completed by using a two wire, twisted pair, shielded, cable. If you are using a terminal strip as

shown in the previous drawing, connect the Data (+) wire to terminal 4 of the terminal strip. Connect the Data return (-) wire to terminal 3. The shield of the interface cable is also connected to terminal 3 of the strip.

2.2.4 Connection Diagram

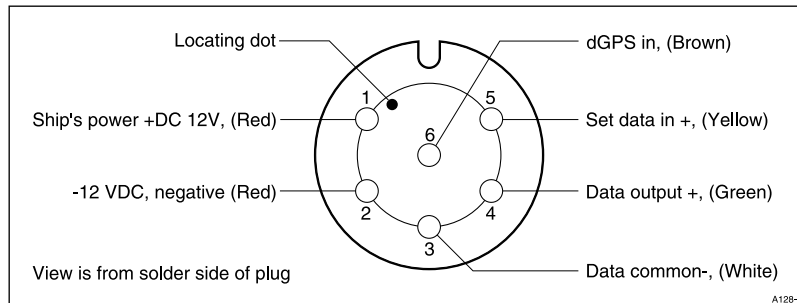

Chapter 3: Operation

3.1 COLD Start (Initial Start-up)

Your GPS is set up for fully Automatic operation when it leaves the factory. All you need to do is turn the unit ON.

When power is applied to the Raystar 112 for the very first time, the GPS sensor has to locate and identify three or more satellites before determining the vessel's actual L/L position. The sensor's memories contain pre-programmed profiles of each satellite's signal coding. So it becomes a matter of sampling the incoming GPS signals and comparing the profiles until the signal coding matches. Unfortunately, this process (similar to matching fingerprints) is both time consuming and complex. It can take up to 10 minutes before the unit completes satellite identification and calculates the first position.

If you are using one of Raytheon's GPS display units, the operator can aid the GPS sensor in its satellite search by entering specific initialization information concerning ship's position, date, and time. The time required for obtaining the initial position fix can be reduced to approximately 1 to 3 minutes once the sensor has received this initialization data.

After the sensor has completed this initial search and determined its location, the sensor will remember the L/L position in memory. The next time you use the unit, the only thing you'll have to do is turn the unit ON. In a few minutes your position will be displayed.

This will occur as long as the ship remains within approximately 100 NM of the L/L position where the unit was turned OFF. If the vessel has been moved a substantial distance from the last saved position and the GPS sensor is then powered up, the unit may again go through the Cold Start routine. The time to acquire the satellites and get your position can be reduced by re-entering your new L/L position, date, and time information.

3.2 Geodetic Datum

The normal Geodetic datum used by the Raystar 112 sensor is WGS-84.

Mariners can/may find considerable errors (up to 200 m) in plotting own ship's position if their charts were created using one type of geodetic

data system while the GPS sensor is busy calculating positions using another data system. When using the Raytheon's GPS display unit, the sensor can be programmed to use different geodetic datums for making position calculations. The datums that may be selected via the display unit are as follows:

No.	Datum Area	Service Area
0	WGS-84	Default GPS datum
1	WGS-72	Loran C
2	BESSEL	Japan
3	NAD-27	USA (older NOAA charts)
4	NAD-27 CAN	Canada/Alaska
5	EUROPEAN 50	Europe
6	AUSTRAL 66	Australia
7	OSGB 36	UK (British Admiralty)
8	NAD 83	USA
9	Other Datums	see Appendix A

When a sensor is programmed for a different datum, the datum will be saved in the sensors internal memory, which is backed-up by internal battery.

If operating this unit with other navigation equipment, refer to the equipment users manual for instructions on set-ups or programming to select and receive external data inputs into those equipments.

Chapter 4: Maintenance

4.1 General

Maintaining satisfactory operation of your **Raystar 112** can depend on how well you care for the equipment. The simple maintenance tips that follow can save you time and money, as well as prevent unnecessary premature failures when the unit is most needed.

Note:

Periodically check system hardware. Inspect the sensor, mount, and cables, making sure all components are free of corrosion and are securely mounted. Examine the cable for evidence of chafing or abrasions. Clean and/or repair as necessary. Make sure connections to the ship's DC power are clean and tight. A light coating of a high insulation silicon grease (such as Dow Corning DC-4) can be used on connector pins to protect the plug contacts from corrosion when used.

4.2 Replacing the Battery

The Raystar 112 contains internal memories to store your position, and other set-up information. A Lithium battery back-up keeps this memory information intact even when the unit is disconnected from the ship's battery.

The estimated life span of the battery is five years. If the battery should fail, the memory contents will be lost. While the Raystar 112 will still operate without the battery, the unit will take longer to acquire a fix each time you use the unit. To insure trouble free operation, it is suggested that the battery be replaced every five years with an exact replacement lithium battery. Your authorized Raytheon distributor or Raytheon Factory Service Center can fit a replacement battery for you.

4.3 Trouble Shooting

All Raytheon products undergo comprehensive testing prior to packaging and shipment from the factory. However, in the unlikely event that a problem arises, the following checks should help to locate the possible cause.

Fault	Cause	Action
No data output after 30 min. operation.	No DC power	1. Check power is switched on. 2. Check fuse/breaker
No satellites No fix	Path blocked	3. Verify antenna is not obstructed and is vertically mounted.
No Data output		4. Check data connections for broken wires.

4.4 Electrical Specifications:

General:

Receiver type:	12 Channel, parallel, highspeed
Frequency:	1575.42 MHz +/- 1MHz (C/A code), L1
Sensitivity:	-130 dBm
Signal Acquisition:	Automatic and computer controlled
Time to first fix:	10 minutes maximum; Less than 3 minutes after first fix.
Maximum No. of tracked satellites:	12
Almanac update:	Automatic
Accuracy (Typical):	
Position:	SA= Off SA= On DGPS=On +/- 15M +/- 100M +/-5 to 8M
Speed:	0.1 kts
Differential Correction:	Accepts RTCM SC-104
Geodetic Datum:	WGS-84 is default; 190 others programmable
Data Output:	Single output port. NMEA 0183 includes RMC, GLL, VTG, GGA, GSA and GSV sentences.
Data Type:	TTL level asynchronous serial data, 4800 baud.
Memory Backup:	Via internal lithium battery, 3-5 years life
Power Requirements:	13.6 VDC, 0.25A nominal (11-16 VDC)

Mechanical Specifications:

Antenna:	ADP
Antenna Construction:	Waterproof to USCG standard CFR 46
Cable Type:	6 conductor, White PVC jacket
Cable Length:	10 meters (33 ft)
Dimensions:	110 x 130 mm (4.3" H x 5.1" W)
Weight:	0.6 kg (1.3 lbs) approximately
Temperature:	-20° to +70°C
Storage Temperature:	-40°C to +85° C

Appendix A

Additional Local Geodetic Systems

- 11 Adindan (Mean for Ethiopia and Sudan)
- 12 ARC 1950 (Mean for Botswana, Lesotho, Malawi, Swaziland, Zaire, Zambia, Zimbabwe)
- 13 Australian Geodetic 1984 (Australia)
- 14 Bermuda 1957 (Bermuda Islands)
- 15 Bogota Observatory (Columbia)
- 16 Campo Inchauspe (Argentina)
- 17 Chatham 1971 (Chatham Island)
- 18 Chua Astro (Paraguay)
- 19 Corrego Alegre (Brazil)
- 20 Djakarta (Batavia) (Sumatra)
- 21 European 1979 (Europe)
- 22 Geodetic Datum 1949 (New Zealand)
- 23 Guam 1963 (Guam)
- 24 Hayford 1910 (Finland)
- 25 Hjorsey 1955 (Iceland)
- 26 Indian (India and Nepal)
- 27 Ireland 1965 (Ireland)
- 28 Kertau 1948 (West Malaysia and Singapore)
- 29 L.C.5. Astro (Cayman Brac Island)
- 30 Liberia 1964 (Liberia)
- 31 Luzon (Philippines (excluding Mindanao))
- 32 Merchich (Morocco)
- 33 Minna (Cameroon)
- 34 Nahrwan (Oman)
- 35 Naparima, BWI (Trinidad and Tobago)
- 36 Old Egyptian (Egypt)
- 37 Old Hawaiian (Hawaiian Islands)
- 38 Pico De Las Nieves (Canary Islands)
- 39 Provisional South American 1956 (Mean for Bolivia, Chile, Columbia, Ecuador, Guyana, Peru, Venezuela)
- 40 Provisional South Chilean 1963 (Southern Chile)
- 41 Puerto Rico (Puerto Rico and Virgin Islands)

- 42 Qornoq (Southern Greenland)
- 43 RT90 (Sweden)
- 44 Santa Braz (Sao Maguel and Santa Maria Islands)
- 45 South American 1969 (Mean for Argentina, Bolivea, Brazil, Chile, Columbia, Ecuador, Guyana, Paraguay, Peru, Trinidad & Tobago, Venezuela)
- 46 Southwest Base (Graciosa Base) (Faial, Graciosa, Pico, Sao Jorge and Terceira Island)
- 47 Timbalai 1948 (Brunei and East Malaysia)
- 50 Adindan (Burkina Faso)
- 51 Adindan (Cameroon)
- 52 Adindan (Ethiopia)
- 53 Adindan (Mali)
- 54 Adindan (Senegal)
- 55 Adindan (Sudan)
- 56 Afgooye (Somalia)
- 57 Ain el Abd 1970 (Bahrain)
- 58 Ain el Abd 1970 (Saudi Arabia)
- 59 Ain el Abd 1970 (Cocos Islands)
- 60 Antigua Island Astro 1943 (Antigua and Leeward Islands)
- 61 Arc 1950 (Botswana)
- 62 Arc 1950 (Burundi)
- 63 Arc 1950 (Lesotho)
- 64 Arc 1950 (Malawi)
- 65 Arc 1950 (Swaziland)
- 66 Arc 1950 (Zaire)
- 67 Arc 1950 (Zambia)
- 68 Arc 1950 (Zimbabwe)
- 69 Arc 1950 (Mean for Kenya and Tanzania)
- 70 Ascension Island 1958 (Ascension Island)
- 71 Astro Beacon E 1945 (Iwo Jima)
- 72 Astro DOS 71/4 (St Helena Island)
- 73 Astro Tern Island 1961 (Tern Island)
- 74 Astronomical Station 1952 (Marcus Island)
- 75 Ayabelle Lighthouse (Djibouti)
- 76 Bellevue (IGN) (Efate and Erromango Islands)

-
- 77 Bissau (Guinea, Bissau)
 - 78 Bukit Rimpah (Indonesia (Bangka and Belitung Islands))
 - 79 Camp Area Astro (Antarctica (McMurdo Camp))
 - 80 Canton Astro 1966 (Phoenix Islands)
 - 81 Cape (South Africa)
 - 82 Cape Canaveral (Bahamas and Florida)
 - 83 Carthage (Tunisia)
 - 84 Dabola (Guinea)
 - 85 DOS 1968 (New Georgia Islands)
 - 86 Easter Island 1967 (Easter Island)
 - 87 European 1950 (Mean for Austria, Denmark, Germany, Netherlands, Switzerland)
 - 88 European 1950 (Mean for Iraq, Israel, Jordon, Lebanon, Kuwait, Saudi Arabia, Syria)
 - 89 European 1950 (Cyprus)
 - 90 European 1950 (Egypt)
 - 91 European 1950 (England, Channel Islands, Scotland, Shetland Islands)
 - 92 European 1950 (Finland, Norway)
 - 93 European 1950 (Greece)
 - 94 European 1950 (Iran)
 - 95 European 1950 (Italy (Sardinia))
 - 96 European 1950 (Italy (Sicily))
 - 97 European 1950 (Malta)
 - 98 European 1950 (Portugal ,Spain)
 - 99 European 1979 (Mean for Austria, Finland, Netherlands, Norway, Spain, Sweden, Switzerland)
 - 100 Fort Thomas 1955 (Nevis, St Kitts (Leeward Islands))
 - 101 Gan 1970 (Maldives)
 - 102 Guam 1963 (Guam)
 - 103 Gunung Segara (Indonesia (Kalimantan))
 - 104 GUX 1 Astro (Guadalcanal Island)
 - 105 Herat North (Afghanistan)
 - 106 Hong Kong 1963 (Hong Kong)
 - 107 Hu-Tzu-Shan (Taiwan)
 - 108 Indian (Bangladesh)

- 109 Indian 1954, (Thailand, Vietnam)
- 110 Indian 1975 (Thailand)
- 111 ISTS 061 Astro 1968 (South Georgia Islands)
- 112 ISTS 073 Astro 1969 (Diego Garcia)
- 113 Johnston Island 1961 (Johnston Island)
- 114 Kandawala (Sri Lanka)
- 115 Kerguelen Island 1949 (Kerguelen Island)
- 116 Kusaie Astro 1951 (Caroline Islands)
- 117 Legion Ghana
- 118 Luzon Philippines (Philippines Mindanao)
- 119 Mahe 1971 (Mahe Island)
- 120 Massawa (Ethiopia (Eritrea))
- 121 Midway Astro 1961 (Midway Island)
- 122 Minna (Nigeria)
- 123 Montserrat Island Astro 1958 (Montserrat (Leeward Islands))
- 124 M'Poraloko (Gabon)
- 125 Nahrwan (Saudi Arabia)
- 126 Nahrwan (United Arab Emirates)
- 127 North American 1927 (NAD27) (Mean for Antigua, Barbados, Barbuda, Caicos Islands, Cuba, Dominican Republic, Grand Cayman, Jamaica, Turks Islands)
- 128 North American 1927 (NAD27) (Mean for Belize, Costa Rica, El Salvador, Guatemala, Honduras, Nicaragua)
- 129 North American 1927 (NAD27) (Mean for CONUS (East of Mississippi River))
- 130 North American 1927 (NAD27) (MEAN for CONUS (West of Mississippi River))
- 131 North American 1927 (NAD27) (Alaska)
- 132 North American 1927 (NAD27) (Bahamas (Except San Salvador Island))
- 133 North American 1927 (NAD27) (Canada (Alberta, British Columbia))
- 134 North American 1927 (NAD27) (Canada (Manitoba, Ontario))
- 135 North American 1927 (NAD27) (Canada (New Brunswick, Newfoundland, Nova Scotia, Quebec)
- 136 North American 1927 (NAD27) (Canada (Northwest Territories, Saskatchewan))

-
- 137 North American 1927 (NAD27) (Canada (Yukon))
 - 138 North American 1927 (NAD27) (Canal Zone)
 - 139 North American 1927 (NAD27) (Cuba)
 - 140 North American 1927 (NAD27) (Greenland (Hayes Peninsula))
 - 141 North American 1927 (NAD27) (Mexico)
 - 142 North American 1983 (Alaska, Canada, CONUS)
 - 143 North American 1983 (Central America, Mexico)
 - 144 Observatorio Metereo 1939 (Azores)
 - 145 Old Hawaiian (Mean for Hawaii, Kauai, Maui, Oahu)
 - 146 Old Hawaiian (Kauai)
 - 147 Old Hawaiian (Maui)
 - 148 Old Hawaiian (Oahu)
 - 149 Oman (Oman)
 - 150 Ordnance Survey of Great Britain 1936 (Mean for England, Isle of Man, Scotland, Shetland Islands , Wales)
 - 151 Ordnance Survey of Great Britain 1936 (England , Isle of Man, Wales)
 - 152 Ordnance Survey of Great Britain 1936 (Scotland, Shetland Islands)
 - 153 Ordnance Survey of Great Britain 1936 (Wales)
 - 154 Pitcairn Astro 1967 (Pitcairn Island)
 - 155 Point 58 (Mean for Burkina Faso and Niger)
 - 156 Pointe Noire 1948 (Congo)
 - 157 Porto Santo 1936 (Porto Santo, Madeira Islands)
 - 158 Provisional South American 1956 (Bolivia)
 - 159 Provisional South American 1956 (Chile (Northern Near 19°S))
 - 160 Provisional South American 1956 (Chile (Southern Near 43°S))
 - 161 Provisional South American 1956 (Columbia)
 - 162 Provisional South American 1956 (Ecuador)
 - 163 Provisional South American 1956 (Guyana)
 - 164 Provisional South American 1956 (Peru)
 - 165 Provisional South American 1956 (Venezuela)
 - 166 Qatar National (Qatar)
 - 167 Reunion (Mascarene Islands)
 - 168 Rome 1940 (Italy, Sardinia)
 - 169 Santa(DOS) 1965 (Espirito Santo Island)

- 170 Sapper hill 1943 (East Falkland Island)
- 171 Schwarzeck (Namibia)
- 172 Selvagem Grande (Salvage Islands)
- 173 SGS 85 Soviet Geodetic System 1985 (Russia)
- 174 South American 1969 (Argentina)
- 175 South American 1969 (Bolivia)
- 176 South American 1969 (Brazil)
- 177 South American 1969 (Chile)
- 178 South American 1969 (Columbia)
- 179 South American 1969 (Ecuador)
- 180 South American 1969 (Ecuador (Baltra, Galapagos))
- 181 South American 1969 (Guyana)
- 182 South American 1969 (Paraguay)
- 183 South American 1969 (Peru)
- 184 South American 1969 (Trinidad & Tobago)
- 185 South American 1969 (Venezuela)
- 186 South Asia (Singapore)
- 187 Tananarive Observatory 1925 (Madagascar)
- 188 Tokyo (Japan)
- 189 Tokyo (Korea)
- 190 Tokyo (Okinawa)
- 191 Tristan Astro 1968 (Tristan de Cunha)
- 192 Viti Levu 1916 (Fiji (Viti Levu Island))
- 193 Wake-Eniwetok 1960 (Marshall Islands)
- 194 Wake Island Astro 1952 (Wake Atoll)
- 195 Yacare (Uruguay)
- 196 Zanderij (Suriname)
- 197 Reserved
- 198 Reserved
- 199 Reserved
- 200 User Defined



Raytheon Marine Company
676 Island Pond Road
Manchester, NH 03109-5420
TEL (603) 647-7530
FAX (603) 634-4756

Raytheon Marine Europe Ltd.
Anchorage Park, Portsmouth,
Hampshire, PO3 5TD, England
TEL (01705) 693611
FAX (01705) 694642

Raytheon Electronics