

Distributed by  
**Raymarine**

Any reference to Raytheon or RTN in this manual should be interpreted as Raymarine. The names Raytheon and RTN are owned by the Raytheon Company.

## GENERAL OPERATION

### Alarms

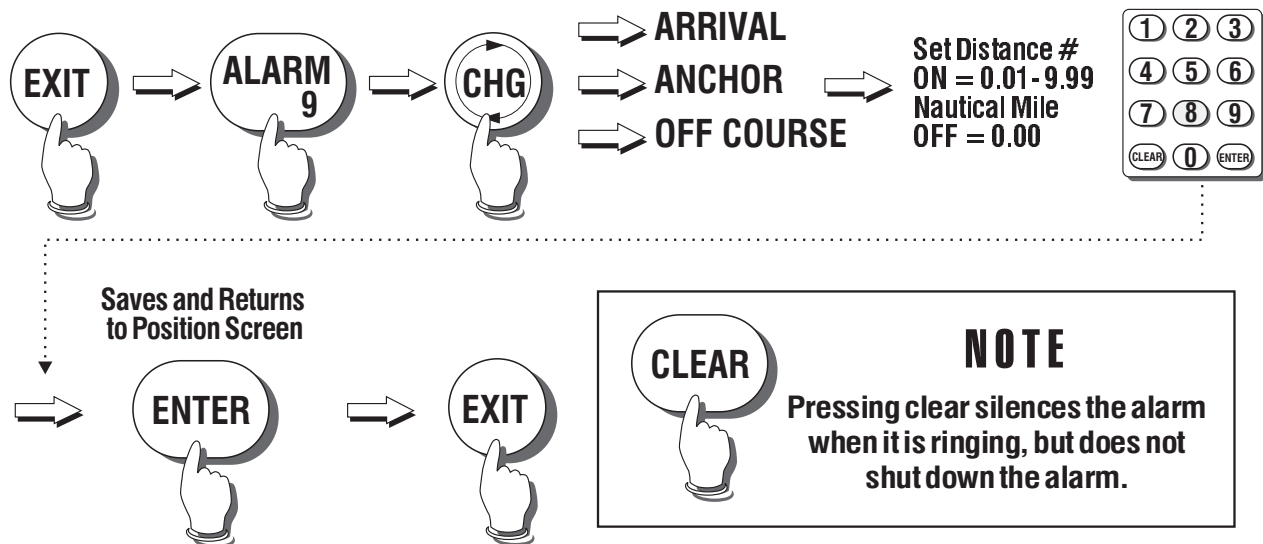

### Turning On/Off Backlighting



### Man Overboard



**EVENTS**

**Saving Events into Waypoint Memory**

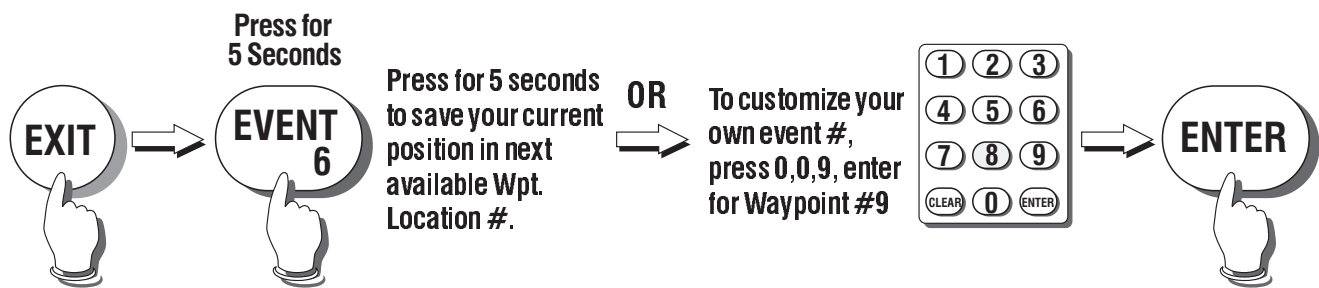

\*NO WAYPOINT CAN BE OVERWRITTEN IF IT IS PART OF A ROUTE.

**Navigating to Stored Waypoints**



## ENTERING WAYPOINTS

### Saving Wpt's in Memory (Lat./Long.)

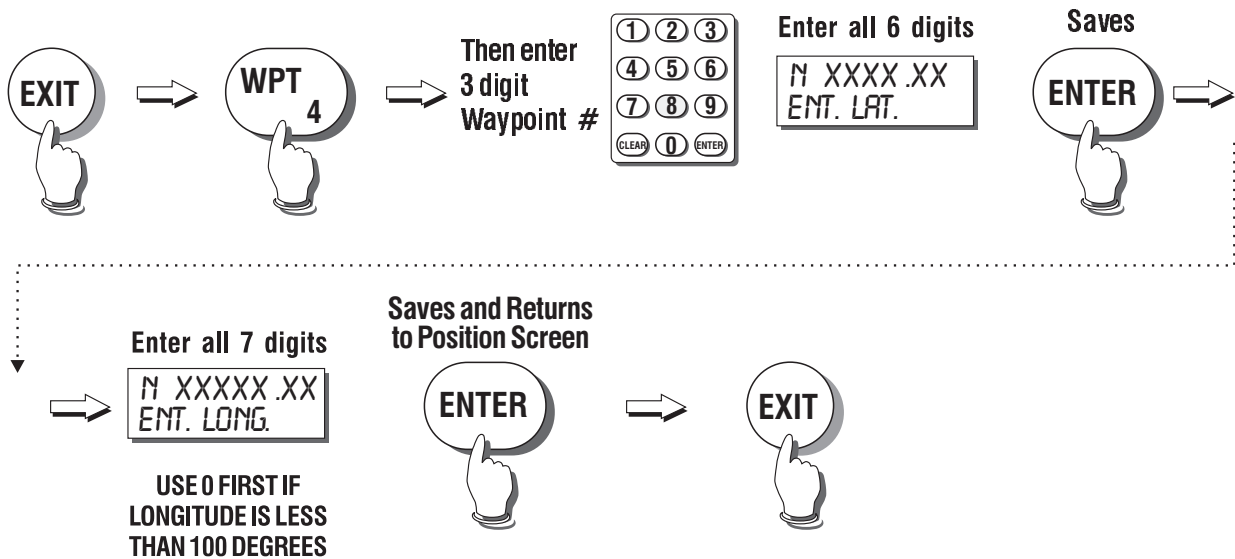

### Saving Wpt's in Memory (T.D.)

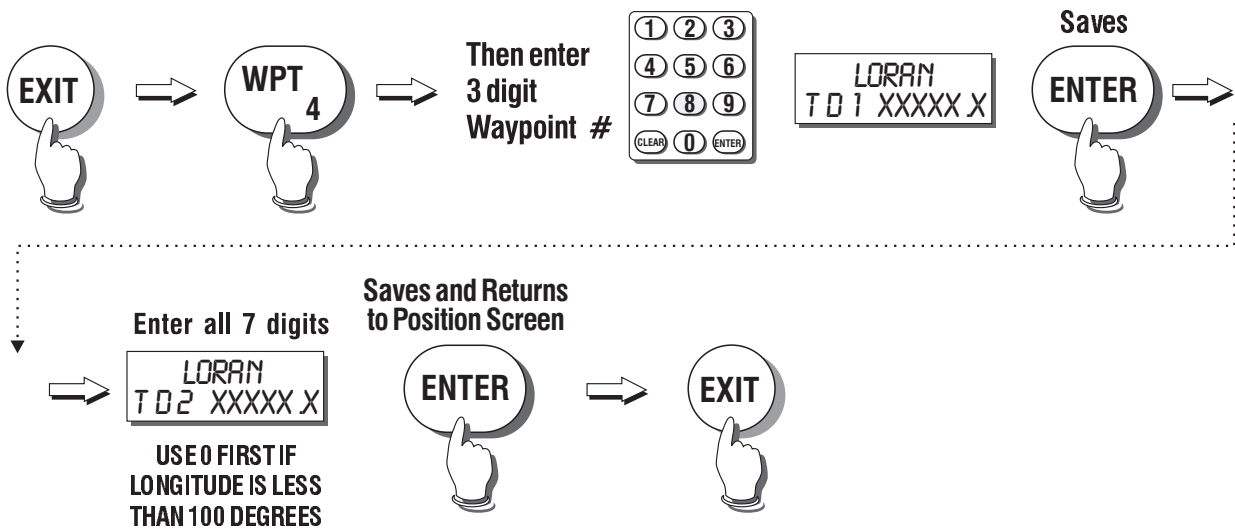

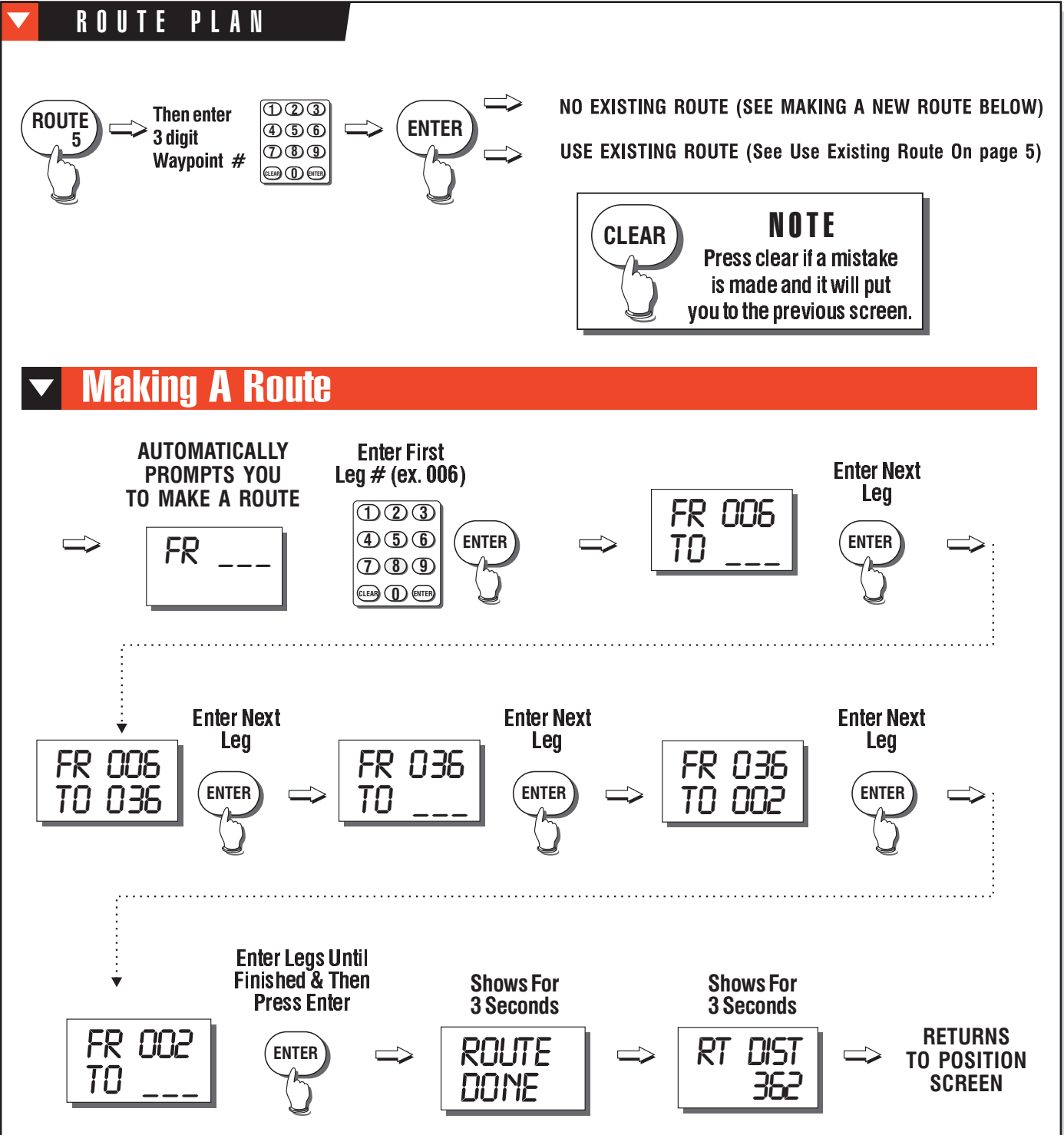

## ROUTE PLAN

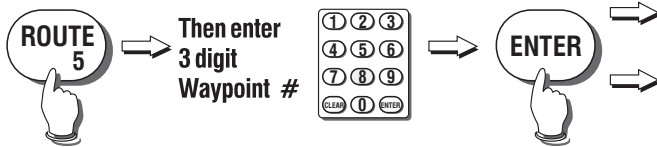

NO EXISTING ROUTE (See Making A New Route on page 4)

USE EXISTING ROUTE (SEE USE EXISTING ROUTE BELOW)

**CLEAR** **NOTE**

Press clear if a mistake is made and it will put you to the previous screen.

## Use Existing Route

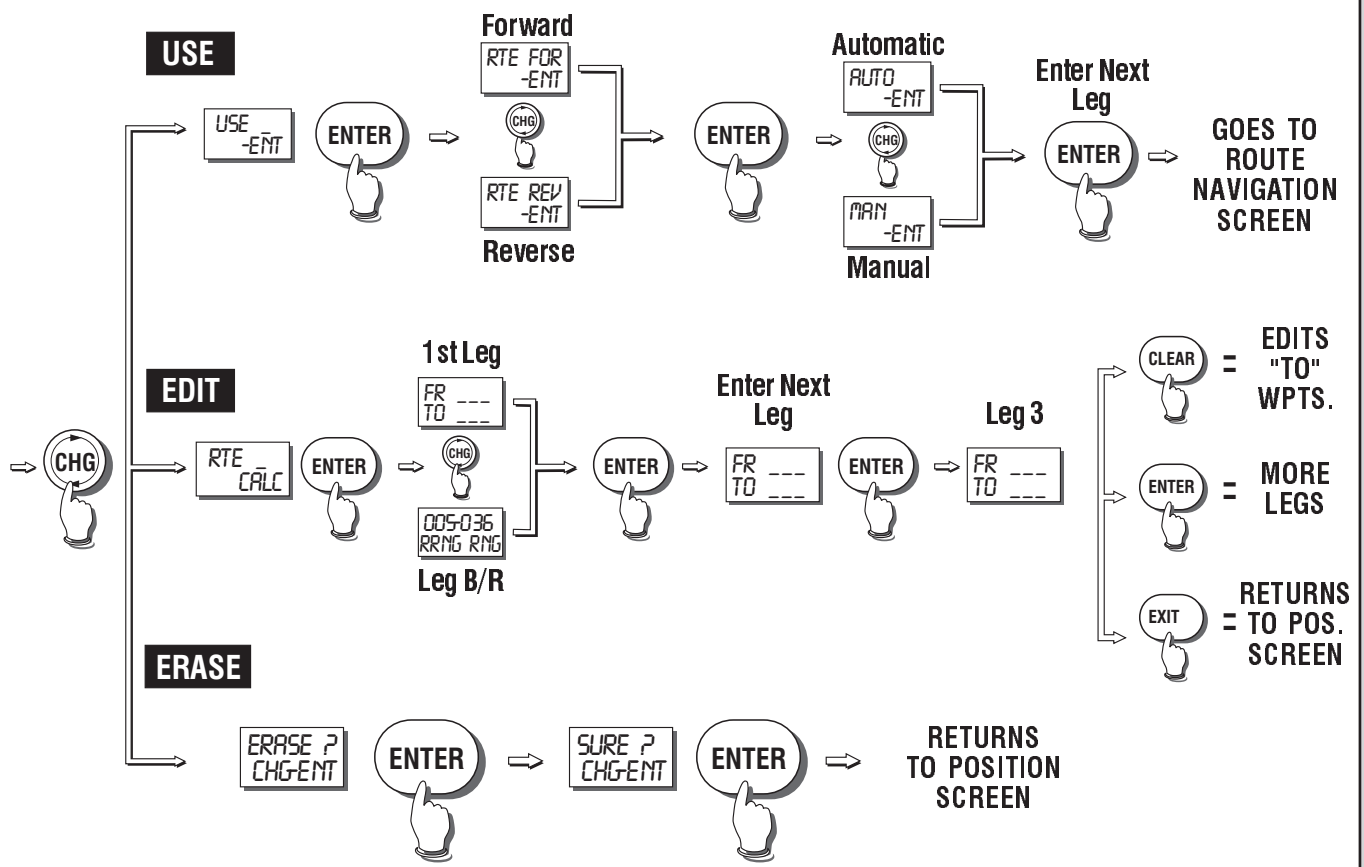

### KEYPAD FUNCTIONS

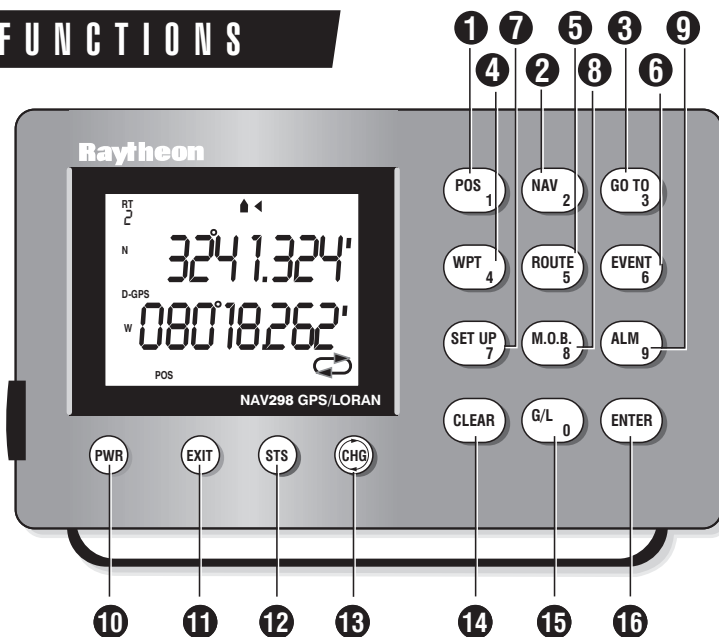

KEY SYMBOL	FUNCTION
1 POS 1	Selects digit 1; selects Position displays.
2 NAV 2	Selects digit 2; selects Navigation displays.
3 GO TO 3	Selects digit 3; selects a Waypoint as a destination.
4 WPT 4	Selects digit 4; selects Waypoint entry function.
5 ROUTE 5	Selects digit 5; selects Route functions.
6 EVENT 6	Selects digit 6; Memorizes ship's present position into next empty Waypoint memory.
7 SET UP 7	Selects digit 7; selects various MENU functions.
8 M.O.B. 8	Selects digit 8; selects Man-Overboard special Alarm function.
9 ALM 9	Selects digit 9; fast escape key, abandons entry modes and returns to Position display.
10 PWR	Turns power On/Off; turns backlighting On/Off.
11 EXIT	Escape key, abandons operation and returns to Pos display mode.
12 STS	Accesses Loran or GPS signal status.
13 CHG	Rotates menus within a function, selects +/-, N/S, E/W, in Position mode.
14 CLEAR	Removes data from entry; resets numeric values to 0; silences audio beeper.
15 G/L 0	Selects digit 0; Loran C or GPS operations.
16 ENTER	Accepts data for entry; advances to the next menu.